

TEST REPORT
AS/NZS 3112:2017
Approval and test specification—Plugs and socket-outlets
Australian plug test

Report reference No: RKSA180606050-SA-M1

Compiled by (+ signature): Engineer: Andy *Andy fu*

Approved by (+ signature): Team leader: Robin *Robin He*

Date of issue: 2018-06-22

Testing laboratory: Bay Area Compliance Laboratories Corp. (Dongguan)

Address: No.69,Pulongcun,Puxinhu Industry Area, Tangxia, Dongguan, Guangdong, China

Testing location: See above

Accreditation.....: The IAS Accreditation Number TL-460.

Applicant's name: GlobTek,Inc.

Address.....: 186 Veterans Dr. Northvale, NJ 07647 USA

Manufacturer's name.....: GlobTek,Inc.

Address.....: 186 Veterans Dr. Northvale, NJ 07647 USA

Factory's name: GlobTek (Suzhou) Co.,Ltd

Address.....: Building 4,No.76 JinLing East Road, Suzhou Industrial Park, Suazhou, JiangSu, 215021, China

Standard: AS/NZS 3112:2017

Test sample(s) received: 2018-06-06

Test in period.....: 2018-06-19 To 2018-06-22

Procedure deviation: N.A.

Non-standard test method: N.A.

Note: The test data was only valid for the test sample(s). This test report is prepared for the customer shown above and for the specific product described herein. It must not be duplicated or used in part without prior written consent from Bay Area Compliance Laboratories Corp. (Dongguan).

Type of test object	Power Supply
Trademark	
Model/type reference	GTM41076-06VV-X.X series (see page 4)
Mutiple Models	GT-41052-AABB-X.X series, GT-41080-WWVV-X.X series, GT-41081-WWVV-X.X series, GT-41135-WWVV-X.X series, GT-43007-WWVV-X.X series, GT-41062-AABB-X.X series, GT*41080-**** series, GTM43033-*** series, GT-46120-WWVV-X.XX-W2Z*****, GT-46180-WWVV-X.XX*****, GT*41134*****, and GT*96060*****, GT**.-*****, GT-46240-WWVV-X.XX*****, GT*46402-***(see page 4-7)
Manufacturer	GlobTek, Inc.
Rating	(for adapter GTM41076-06VV-X.X series models) Input:100-250V~50-60Hz, 0.16-0.1A Output:5-30Vdc , Max 6W

Copy of marking plate(representative):

(for adapter) (GTM41076-06VV-X.X series models representative)

GlobTek, Inc.
186 Veterans Dr.
Northvale, NJ 07647 USA
www.globtek.com

开关电源适配器/电源供应器

VCCI MEDICAL POWER SUPPLY
CLASS 2 POWER SUPPLY
仅适用于海拔2000m以下地区使用

P/N(料号/料號): WR9QA1200CCP-N-MED(R)
MODEL(型号/型號): GTM41076-0605
INPUT(输入/輸入): 100-240V~, 50-60Hz, 0.16-0.1A
OUTPUT(输出/輸出): 5V --- 1.2A, 6W

CCC 30 R32282

UL US E172861

SI

ENERGY EFFICIENCY PS VERIFIED

N4292 SAA120085

Glob Tek, Inc.

CAUTION/ATTENTION:
Risk of electric shock/Risque de choc électriques.
Dry Location use only/Utilisation à l'intérieur Seulement

10139 PG

MADE IN CHINA (中国制造/中國製造) IP40 RoHS 2

Models description:

Models series	description
GTM41076-06VV-X.X series	were VV can be any rated output voltage between 5 and 30 Vdc and X.X is optional for specifying output voltage deviations, -X.X denotes the optional deviation, subtracted or added from standard output voltage in 0.1 volt increments or blank to indicate the no voltage different.
GT-41052-AABB-X.X series	"AA" is the rated output wattage designation, with a maximum value of "15"; "BB" is the standard rated output voltage designation, with values between "05" to "48"; and, -X.X denotes the optional deviation, subtracted or added from standard output voltage in 0.1 volt increments or blank to indicate the no voltage different.
GT-41080-WWVV-X.X series	WW is the rated output wattage designation, with a maximum value of "18".VV is the standard rated output voltage designation, with a maximum value of "48". -X.X denotes the optional deviation, subtracted or added from standard output voltage in 0.1 volt increments or blank to indicate the no voltage different, Actual voltage range is 9 - 48 volts only.
GT-41081-WWVV-X.X series	WW is the rated output wattage designation,with a maximum value of "18";VV is the standard rated output voltage designation,with a maximum value of "09"; -X.X denotes the optional deviation, subtracted or added from standard output voltage in 0.1 volt increments or blank to indicate the no voltage different.
GT-41135-WWVV-X.X series	WW is the rated output wattage designation, with a maximum value of "12";VV is the standard rated output voltage designation, with a maximum value of "48"; -X.X denotes the optional deviation, subtracted or added from standard output voltage in 0.1 volt increments or blank to indicate the no voltage different.
GT-43007-WWVV-X.X series	WW is the rated output wattage designation, with a maximum value of "40.8"; VV is the standard rated output voltage designation, with a maximum value of "24"; -X.X denotes the optional deviation, subtracted or added from standard output voltage in 0.1 volt increments or blank to indicate the no voltage different.

<p>GT-41062-AABB-X.X series</p>	<p>AA denotes the maximum rated wattage, either "13" or "18", BB denotes the standard maximum rated voltage, which may be 5.0-24.0 Vdc as shown in the ratings table, -X.X denotes the optional deviation, subtracted or added from standard output voltage in 0.1 volt increments or blank to indicate the no voltage different.</p>
<p>GT*41080-**** series</p>	<p>The 1st "*" part can be „M“ or „-“ or „H“ for market identification and not related to safety.</p> <p>The 2nd "*" part denotes the rated output wattage designation, which can be "01" to "18", with interval of 1.</p> <p>The 3rd "*" part denotes the standard rated output voltage designation, which can be "07", "11", "17.9", "30", "38" and "48". Each standard rated output voltage designation corresponds to a transformer model. Each transformer model is identical in insulation construction including clearance and creepage except number of turns per coil.</p> <p>The 4th "*" part is optional, which can be "-0.1" to "-12" with interval of 0.1 to denote voltage deviation or blank to indicate no voltage different. The result by subtracting the deviation value from the standard rated output voltage denotes the rated output voltage, with a range of 5 – 48 volts.</p>
<p>GTM43033-*** series</p>	<p>M can be "M" or "-" for market identification and not related to safety</p> <p>The 1st "*" part denotes the rated output wattage designation, which can be "01" to "06", with interval of 1.</p> <p>The 2nd "*" part denotes the standard rated output voltage designation, which can be "03", "04", "06", "12", "15", "18", "24", "36" or "48". These standard rated output voltage designations correspond to three transformer models. Each transformer model is identical in insulation construction including clearance and creepage except number of turns per coil.</p> <p>The 3rd "*" part is optional, which can be "-0.1" to "-11.9" with interval of 0.1 to denote voltage deviation or blank to indicate no voltage different. The result by subtracting the deviation value from the standard rated output voltage denotes the rated output voltage, with a range of 3 – 48 volts.</p>

GT-46120-WWVV-X.XX-W2Z*****	<p>WW is the standard output wattage, with a maximum value of "12", VV is the standard rated output voltage designation, with a maximum value of "48", which can be 05,06,09,12,15,24,36,48.</p> <p>-X.XX denote the output voltage differentiator, subtracting X.XX volts from standard output voltage VV in 0.01V increments, the actual output voltage range is 5-48V, blank is to indicate the no voltage different.</p> <p>Z denote type of plug and can be E for European plug, U for British plug, blank for North American/Japan/Taiwan plug, C for Chinese plug, A for Australia plug. -W2Z can be optional, when it is blank, denote to be with replaceable plug.</p> <p>Each * = 0-9 or A-Z or () [] - or blank for marketing purposes.</p>
GT-46180-WWVV-X.XX*****	<p>WW is the standard output wattage, with a maximum value of "18", VV is the standard rated output voltage designation, with a maximum value of "24"; which can be 05,09,12,15,18,24.</p> <p>-X.XX denote the output voltage differentiator, subtracting X.X volts from standard output voltage VV in 0.01V increments, the actual output voltage range is 5-24V, blank is to indicate the no voltage different.</p> <p>Each * = 0-9 or A-Z or () [] - or blank for marketing purposes.</p>
GT*41134***** and GT*96060*****	<p>The 1st "*" part can be 'M' or '-' or 'H' for market identification and not related to safety.</p> <p>The 2nd "*" part can be "-" or "CC", "-" = Constant Voltage Model, CC = Constant Current Model.</p> <p>The 3rd "*" denotes the rated output wattage designation, which can be "01" to "06", with interval of 1.</p> <p>The 4th "*" denotes the standard rated output voltage designation, which can be "03", "04", "06", "12", "15", "18", "24", "36" or "48". The 5th "*" is optional deviation, subtracted from standard output voltage, which can be "-0.1" to "-11.9" with interval of 0.1, or blank to indicate no voltage different.</p> <p>The 4th "*" and 5th "*" together denote the output voltage, with a range of 3.3 - 48 volts.</p> <p>The 6th "*" = Blank means directly plug in model series, The last * denote any six character = 0-9 or A-Z or () [] or - or blank for marketing purposes.</p>
GT**.-*****	<p>The 1st "*" part can be 'M' or '-' or 'H' for market identification and not related to safety.</p> <p>The 2nd "*" can be 96180.</p> <p>The 3rd "*" denotes the rated output wattage designation, which can be "01" to "36", with interval of 1.</p>

	<p>The 4th “*” denotes the standard rated output voltage designation, when the 2nd “*” = 96180 which can be “07”, “11”, “17.9”, “30”, “38”, “48”, “54” or “56”;</p> <p>The 5th “*” is optional deviation, subtracted from standard output voltage, which can be “-0.01” to “-12.0” with interval of 0.01, or blank to indicate no voltage different.</p> <p>The 4th “*” and 5th “*” together denote the output voltage, with a range of 5 - 56 volts.</p> <p>The 6th “*” = blank, it means wall plug in with interchangeable blade.</p> <p>The last * denote any six character = 0-9 or A-Z or ()[] or – or blank for marketing purposes.</p>
<p>GT-46240-WWVV-X.XX*****</p>	<p>WW is the standard output wattage, with a maximum value of "24",</p> <p>VV is the standard rated output voltage designation, with a maximum value of "24"; which can be 12, 15 and 24.</p> <p>-X.XX denote the output voltage differentiator, subtracting X.X volts from standard output voltage VV in 0.01V increments, the actual output voltage range is 12-24V, blank is to indicate the no voltage different.</p> <p>Each * = 0-9 or A-Z or ()[] - or blank for marketing purposes.</p>
<p>GT*46402-***</p>	<p>The 1st “*” part can be ‘M’ or ‘-’ or ‘H’ for market identification and not related to safety. The 2nd “*” denotes the rated output wattage designation, with a maximum value of "40". The 3th “*” denotes the standard rated output voltage designation, which can be “05” to “48”</p> <p>The last * denote any six character = 0-9 or A-Z or ()[] or - or blank for marketing purposes.</p>

Notes:

1. The follows is stated and guaranteed by applicant. All above models have same structure and same case, and just have different output voltage and current, it does not affect the plug test. GTM41076-0605 is selected for test.
2. Compared with original report RKSA180606050-SA issued by BACL. This report only add result-remark, other conference and modified partial data in the test report, see J3.3 and Appendix I.
3. The original report RKSA180606050-SA is replaced by this report.

AS/NZS 3112			
Clause	Requirement + Test	Result - Remark	Verdict
J1	Scope		P
J2	Definitions		P
J2.1	Detachable plug portion		P
	(a) Type A (see Figure J1)	A detachable plug portion with a connection intended for plugging directly into equipment.	N
	(b) Type B (see Figure J2)	A detachable plug portion with a non-standardized connection intended for plugging directly into equipment.	P
	(c) Type C	A detachable plug portion with a connection intended for use with an adaptor connected to a flexible cord so as to replicate a supply plug and flexible cord configuration.	N
J2.2	Integral plug portion		N
J2.3	Plug portion		P
J3	Requirement for the plug portion		P
J3.1	General	(c) For Type B detachable plug portion, the conformance is shown by the relevant clauses of this Appendix.	P
J3.2	Plug pins of plug portions		P
	Material for pins	Copper content: >58%	P
	Assembly of pins		P
	Form of pin	(a) Flat pins, as shown in figure 2.1(h), 6mm for all pins of 10A plugs and live pins of 15A plugs; and Thickness profile with each corner bevelled 0.3mm to 0.4mm along the side, finishing along the pin at 0.8 mm to 1.0 mm.	P

AS/NZS 3112			
Clause	Requirement + Test	Result - Remark	Verdict
	Insulation of plug pins	Conformance is checked by measurement to Figure 2.4.	P
J3.3	Ratings and Dimensions for low-voltage plug portions		P
	General		P
	Low voltage flat-pin plugs shall conform to the appropriate dimensions shown in Figure 2.1.		P
	The distance between a live pin of any plug and the Edge of the moulding of the plug, shall be not less than 9mm.	11.4 mm	P
	No point on the front face of the plug is more than 0.5mm.	0.15mm	P
	Compliance with dimensional requirements of figure 2.1	See dimension tables	P
	Integrally moulded plug and cord		N
	Two-pin flat-pin plugs with non-parallel pins	Arranged as in Figure 2.1(c)	P
	Conformance with dimensional requirements of Figure 2.1		P
J3.4	Internal connections for plug portions		N
J3.5	Arrangement of earthing connections for plug portions	No earth connector	N
J3.6	Configuration of plug portions		P
J4	TESTS		P
J4.1	General		P
J4.2	High voltage test(2.13.3)		P
	The plug shall withstand without failure an a.c. voltage of the value indicated in table 2.3, applied between the parts set out in items (a) and (c) of Clause 2.13.2 for 1min in each case	1000Va.c., no break down.	P
	The plug shall further withstand, without failure, a voltage of 3000Va.c. applied between the parts set out in items (b) and (d) of clause 2.13.2 for 1min in each case		N
	The insulation of insulated pin plugs shall withstand a voltage of 1250Va.c. for 1min applied in accordance with clause 2.13.1(e)	1250Va.c., no break down.	P
J4.3	Mechanical strength of pin tests		P
J4.3.1	Tumbling barrel test(2.13.7.1)		P
	The tumbling barrel test is applied of to determine the mechanical strength of the plug pins		P

AS/NZS 3112			
Clause	Requirement + Test	Result - Remark	Verdict
	Three samples which have not been subjected to any previous test are tested to the requirements of clause 2.13.7, however, the test is modified for plug portions of equipment with integral pins as follows:		P
	A sample of equipment with integral pins is dropped-		--
	a) 500 times if the mass of the specimen does not exceed 250g. The pins being straightened after each 100 drops and at the completion of the test to pass through the appropriate gauge of figure A1, B1 or F1; and	Max. 170g. After test, no broken and cracking was found.	P
	b) 250 times if the mass of the specimen exceeds 250g. The pins being straightened after 25 drops and at the completion of the test to pass through the appropriate gauge of figure A1, B1 or F1;		--
J4.3.2	Pin bending test		P
	The pins of the plug portion of three samples not subjected to any previous tests shall be tested for Compliance with the pin bending test of clause 2.13.7.2	Three samples tested	P
	All flat-pins of plug rated up to and including 15A shall be subjected to a pin bending test	Tested on all flat-pins of plug	P
	Three samples plugs not subjected to any previous tests shall be tested. After the tests the pins shall be inspected with normal or corrected to normal vision	Inspected with normal vision	P
	Active and neutral pins shall be forced towards the centroid of the plug and then back to the starting point. On the first sample plug, any earth pin shall be forced but in one direction only and the back to the starting point. On the second sample plug, any earth pin shall be forced in the opposite direction to that used for testing the first sample plug. On the third sample plug, any earth pin shall be forced in the direction that gave the least favorable result during testing of the first two sample plugs. (Amendment 1:2006)	Without earth pin	N
	The pin shall not be broken off. If in doubt pins shall be disassembled from the plug and any insulation removed.	The pin did not break off.	P
J4.4	Temperature rise test (2.13.8)		P
	The terminal screws or nuts are tightened with a torque equal to two-thirds of that specified in test No. 5	No screws or nuts used	N
	The test socket shall consist of a fixed socket outlet of a type complying with this standard.	Direct plug-in equipment	N
	The plug is inserted into the socket outlet and an alternating current of 1.1 times rated current is passed for 1h.		P

AS/NZS 3112			
Clause	Requirement + Test	Result - Remark	Verdict
	The temperature of the flexible cord terminal is determined by means of melting particles, colour changing indicator or thermocouples, so chosen and positioned that they have negligible effect on the temperature being determined.		N
	The temperature rise of the terminals shall not exceed 45K	Max.temperature rise: Right pin:3.7 K Left pin:1.7 K Surface:3.2 K	P
J4.5	Securement of pins of the plug portion(2.13.9)		P
	Movement of pins (2.13.9.1)		P
	Plug shall be tested for pin movement by clamping the pin or pins not under test in a rigid holding block positioned 5 ± 0.5 mm from the plug face and applying a force of 18 ± 1 N to the pin under test. The design of the block shall be such that the pin under test shall not come into contact with the block during the test		P
	Except for non-rewireable plugs, the test shall be carried out without a cord attached to the plug, and with the terminal screws loosened sufficiently to allow a 1mm^2 conductor to be connected		P
	The plug and test equipment shall be preconditioned at a temperature of $40 \pm 1^\circ\text{C}$ for 1h, Without the test force applied. Throughout the test, all parts of the plug and test equipment shall be maintained at this temperature	40°C for 1h applied	P
	For all plugs, the point of application of the force of plug along the pins, and the direction of the force shall be- a) in both directions along the line perpendicular to the plane of the pin, and passing through the centre of the pin; and b) in that plane in both directions along a line at right angles to that specified in item(a)		P
	Over a period of 10s, the force shall be gradually applied to each of the pins in the manner prescribed in item(a) and (b), maintained at its maximum value for 10s, and then released. The deflection of the pins shall be measured along the line of the face relative to the face of the rigid holding block during the period when force is applied. The maximum deflection shall not exceed 2.0mm	Max.deflection of L pin: 0.2mm; Max. Deflection of N pin: 0.2mm	P

AS/NZS 3112			
Clause	Requirement + Test	Result - Remark	Verdict
	Following the test on all pin of a conforming to Figure 2.1, any distortion 5 min after the completion of the test on the last pin shall be such that it will not prevent the plug from being inserted in the appropriate standard gauges shown in Appendix A, Appendix B and Appendix F without the application of undue force	Plug portion is able to be inserted into the appropriate standard gauge without the application of undue force	P
	For other types of plugs, any distortion after 5min shall be such as will not prevent the plug being inserted into an appropriate socket-outlet without the application of undue force		P
	Fixing of pins(2.13.9.2)		P
	A separate sample of a plug shall be heated to temperature of $50 \pm 2^{\circ}\text{C}$ for 1h and maintained at that temperature during the whole of tests, including the 5 min period after removal of the test load.	50°C for 1h applied.	P
	The plug shall be held firmly in such a manner that there will be no undue squeezing or distortion of the body, and the means of holding shall not assist in maintaining the pins in their original position	The test with the pins in their original position not distortion	P
	Each pin, in turn, shall have applied to it a force which, over a period of 10s, shall be increased steadily to $60 \pm 0.6\text{N}$ and held at this value for 10 min	60N, 10min	P
	Two tests on each pin shall be conducted, one with the direction of force along the length of the pin towards the body of the plug, and the other with the direction of force along the length of the pin away from the body	considered	P
	The attachment of pins shall be considered inadequate if any pin is displaced relative to the adjacent material of the body by more than 2.4mm at any time during these tests, or if any pin fails to return to within 0.8mm of its nominal length specified in figure 2.1 within 5 min of the removal of the test force.	During the test, Max. Displacement: L: 0.21 mm; N: 0.21 mm After removal of the force, Max. Displacement: L: 0.18 mm; N: 0.20 mm	P
J4.6	Tests on the insulation material of insulated pin-plug portions(2.13.13)		P
	2.13.13.1 General		P
	The material of the pin-insulation shall be resistant to the stresses to which it may be subjected at the high temperature likely to occur in conditions approaching the bad connection conditions of service		P
	Compliance shall be checked by the tests of clause 2.13.13.2 to 2.13.13.6		P
	Pressure test at high temperature(2.13.13.2)		P

AS/NZS 3112			
Clause	Requirement + Test	Result - Remark	Verdict
	A sample of one insulated pin only shall be subjected to the following test by means of the apparatus shown in Figure 2.5. This apparatus shall have a blade having a round shape with a diameter of 6 mm and a thickness of 0.7mm.		P
	The sample shall be placed in position as shown in the Figure 2.5 and force of 2.5N shall be applied through the blade to specimen.	2.5N applied	P
	The apparatus,with the sample in position,shall be maintained for 2h in a heating cabinet at a temperature of $160 \pm 5^{\circ}\text{C}$.The sample shall then be removed from the apparatus and within 10s,cooled by immersion in cold water.	160°C for 2h applied.	P
	The thickness of the insulation shall be measured immediately at the point of impression.		P
	The thickness of the insulation remianing at the point of impression shall be measured and shall not have been reduced by more than 50%	Thickness before test: 0.41mm; Thickness after test: 0.36mm; Reduced by 12.20%. The thickness of the insulation.It is not reduced by more than 50%	P
	Visual inspection shall be made and no cracks on the insulation material shall be visible with normal, or corrected to normal,vision without additional magnification,and the dimension of the insulating material shall not have changed below the minimum siz shown in Figure 2.4	No cracks are found on the insulating material.The dimension of insulating material did not changed	P
	Static damp heat test(2.13.13.3)		P
	An insulated pin plug shall be subjected to two damp heat cycles in accordance with AS 60068.2.30.Db(12+12h cycle),95% relative humidity, Lower temperature $25 \pm 3^{\circ}\text{C}$ and upper temperature 40°C		P
	After this treatment and recovery to room temperature,the specimen shall be subjected to- a) the insulation resistance test in accordance with Clause 2.13.2(e); b) high voltage test in accordance with Clause 2.13.3 and; c) abrasion test in accordance with Clause 2.13.13.6	During high voltage test no breakdown occurred between live poles and insulation of th pins.	P
	Low temperature test(2.13.13.4)		P

AS/NZS 3112			
Clause	Requirement + Test	Result - Remark	Verdict
	An insulated pin plug shall be maintained at $-15 \pm 2^{\circ}\text{C}$ for at least 24h and returned to room temperature	-15°C for 24h applied.	P
	The sample shall be subjected to- a) the insulation resistance test in accordance with Clause 2.13.2(e); b) high voltage test in accordance with Clause 2.13.3 and; c) abrasion test in accordance with Clause 2.13.13.6		P
	Impact test at low temperature(2.13.13.5)		P
	A specimen of one insulated pin only shall be subjected to an impact test by means of the apparatus shown in Figure.2.6. The mass of the falling weight shall be $100 \pm 1\text{g}$		P
	The apparatus, on a sponge rubber pad 40mm thick, together with the sample, shall be maintained at $-15 \pm 2^{\circ}\text{C}$ for at least 24h	-15°C for 24h applied	P
	At the end of this period, the sample shall be placed in position, as shown in Figure 2.6, and the falling weight shall be allowed to fall from a height of 100mm. Four impacts shall be applied successively to the same sample, rotating it through 90°C between impacts.		P
	After the test, the sample shall be allowed to return to room temperature and then examined. No cracks of the insulating material shall be visible with normal, or corrected to normal, vision without additional magnification.	No cracks were found on the insulating material	P
	Abrasion test(2.13.13.6)	Use the same sample which passed the Static damp heat test(2.13.13.3) and Low temperature test(2.13.13.4) For abrasion test.	P
	An insulated pin of an insulated plug shall be subjected to the following test by means of an apparatus as shown in Figure 2.7		P
	The test apparatus comprises a horizontally disposed beam, which shall be pivoted about its centre point. A short length of steel wire, 1mm in diameter and bent into U-shape, the base of the U being straight, shall be rigidly attached, at both ends, to one end of the beam, so that the straight part projects below the beam and shall be parallel to the axis of the beam pivot.		P

AS/NZS 3112			
Clause	Requirement + Test	Result - Remark	Verdict
	The plug shall be held in a suitable clamp in such a position that the straight part of the steel wire rests on the major axis face of the plug pin, at right angles to it. The pin shall slope downwards at an angle of 10° to the horizontal.		P
	The beam shall be loaded so that the wire exerts a force of 4N on the pin	4N applied	P
	The plug shall be moved backwards and forwards in horizontal direction in the plane of the axis of the beam, so that the wire rubs along the pin. The length of the pin thus abraded shall be approximately 9mm, of which approximately 7mm shall be over the insulation.		P
	The number of movements shall be 20000 (10000 in each direction) and the rate of operation shall be 30 movements per min.		P
	After the test, the pins shall show no damage which may affect safety or impair the further use of the plug, in particular, the insulating sleeve shall not have punctured or rucked up.	The pins show no damage and the insulating sleeve was not punctured or rucked up.	P
J4.7	Equipment with a plug portion intended to be supported by the contacts of a socket-outlet	Max. Torque Measurement: Normal Position: 0.10 Nm; Reverse Position: 0.10 Nm Limit: ≤ 0.25 Nm	P
J4.8	Additional requirements for detachable plug portions		P
J4.8.1	Access to live parts	The design and construction of the detachable plug portion shall be such that it is not possible to contact live parts with the small test finger of Figure 13 of IEC 61032.	P
J4.8.2	Construction of detachable contacts where the input current of the equipment exceeds 0.2A		P
	Conformance with the effectiveness of the contacts is checked by inspection and by the plug portion detachment requirements of Paragraph J4.8.3.		P
J4.8.3	Plug portion detachment requirements		P
J4.8.4	Resistance of insulating material to heat and fire		P
J4.8.4.1	Resistance to heat	Type B detachable plug portions.	P
	Conformance is checked by subjecting the relevant part to the ball pressure test of IEC 60695-10-2.		P
J4.8.4.2	Resistance to fire		P

AS/NZS 3112			
Clause	Requirement + Test	Result - Remark	Verdict
	Plug portions shall comply with the requirements for resistance to fire in accordance with AS/NZS 3100. The glow-wire test temperature 'T' shall be 750°C.	Insulating material supporting live parts: 750°C, and see Appendix III	P

Appendix I: Dimension checked by gauge and measurement

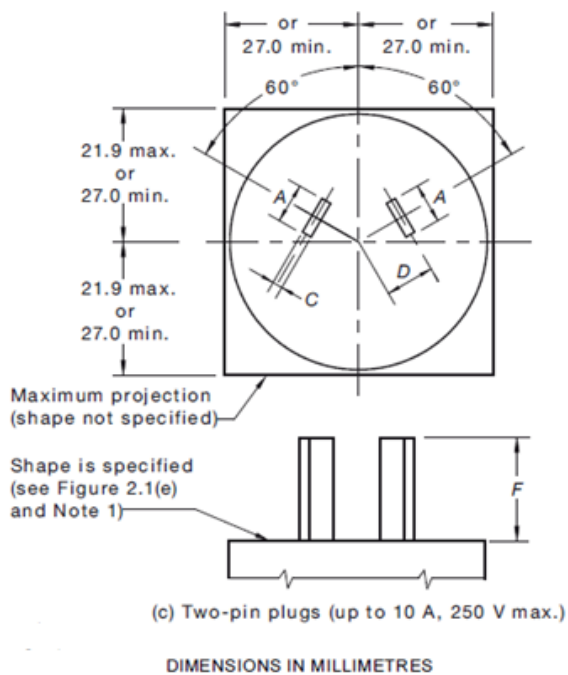

FIGURE 2.1 (in part) DIMENSIONS OF PLUGS

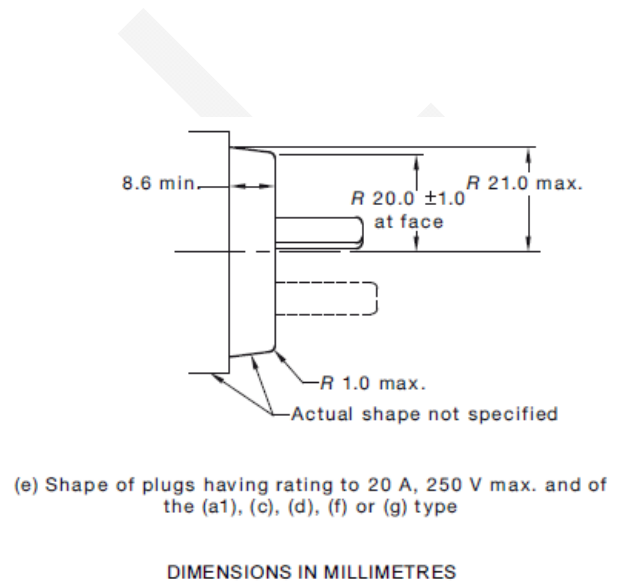

FIGURE 2.1 (in part) DIMENSIONS OF PLUGS

Dimensions of plug			
Location	Requirement(mm)	Measured(mm)	Verdict
Width of left pin(A)	6.35 ± 0.15	6.34	P
Width of right pin(A)	6.35 ± 0.15	6.34	P
Thickness of left pin(C)	1.63 ^{+0.15} _{-0.05}	1.63	P
Thickness of right pin(C)	1.63 ^{+0.15} _{-0.05}	1.63	P
Length of left pin(F)	17.06 ± 0.4	16.88	P
Length of right pin(F)	17.06 ± 0.4	16.88	P

AS/NZS 3112			
Clause	Requirement + Test	Result - Remark	Verdict
	Centre of left and right pins to centre of pin base(D)	7.92*	Fit the testing gauge P
	Pin face radius on enclosure	≤ 21.0	20.95 P
	Pin face radius on pins level	20 ± 1.0	20.75 P
	Radius of pin base	≤ 1.0	0.91 P

Dimensions of plug			
Location	Requirement(mm)	Measured(mm)	Verdict
Distance between pin base and enclosure	≥ 8.6	10.84	P
Width of enclosure left side	≥ 27.0 or ≤ 21.9	20.99	P
Width of enclosure right side	≥ 27.0 or ≤ 21.9	20.99	P
Length of enclosure top side	≥ 27.0 or ≤ 21.9	20.80	P
Length of enclosure bottom side	≥ 27.0 or ≤ 21.9	64.51	P

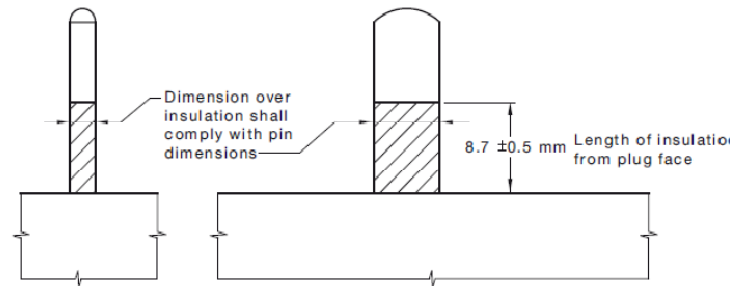
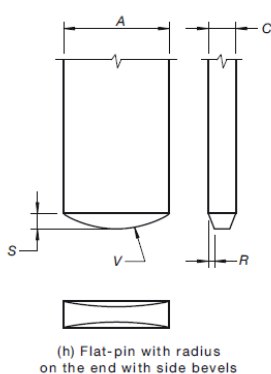

FIGURE 2.4 DIMENSIONS OF INSULATION ON INSULATED LIVE PINS

Dimensions of plug			
Location	Requirement(mm)	Measured(mm)	Verdict
Length of insulation from plug face(left pin)	8.7 ± 0.5	8.74	P
Length of insulation from plug face(right pin)	8.7 ± 0.5	8.74	P
Dimension over insulation of left insulated live pin	$1.63^{+0.15}_{-0.05}$	1.62	P
Dimension over insulation of right insulated live pin	$1.63^{+0.15}_{-0.05}$	1.62	P

AS/NZS 3112			
Clause	Requirement + Test	Result - Remark	Verdict

Dimensions of insulation on insulated live pins (refer to FIGURE 2.1)			
Location	Requirement(mm)	Measured(mm)	Verdict
R	0.35 ± 0.05	Left pin:0.34 Right pin:0.34	P
S	0.9 ± 0.10	Left pin:0.94 Right pin:0.94	P
T	≥ 0.60	--	-
V	6 †	Fit the testing gauge	P

*Dimension C apply to all pins.

†Dimensions without tolerances are nominal. Samples are to be checked with the gauge specified in Appendix A, Appendix B or Appendix F, as appropriate.

Appendix II: Critical Component Parts List:

Object/part No.	Manufacturer/ trademark	Type/model	Technical data	Standard (Edition / year)	Mark(s) of conformity ¹⁾
AU plug	GlobTek, Inc.	Q-SAA	250VAC, 2.5A	---	---
Plastic material of enclosure and Plug holder	SABIC INNOVATIVE PLASTICS US L L C	945(f1), SE1XC2950 , 945(GG), CX7211	Min.1.5 mm thickness V-0, 120°C	UL94	UL
Metal material of plug pin	--	--	Copper content :>58%	--	--

Appendix III	Glow-wire test			P
Test condition	Test specimen: 30mm square Test equipment: A force of 1 N, 15mm or more from the upper edge, into the centre of the surface to be tested. The penetration of the glow-wire into the specimen is mechanically limited to 7mm Test temperature: 750°C. Duration: 30s Tissue paper, spread out horizontally 200±5mm below the specimen			
Part name/location	Test temp.	Ignition of test sample	Ignition of tissue paper	Result
Plastic material of enclosure and Plug holder	750°C	NO	NO	PASS

Appendix IV: Photos

EUT- Whole view 1 of plug



EUT- Whole view 2 of plug



EUT- Whole view 3 of plug



Appendix V: Test Equipment List

NO.	The Name of Equipment	Model	S/N	Calibration Date	Due Date	Capability Range	Manufacturer
T-03-S F343	Digital Caliper	0~200 mm	65585	2018-04-12	2019-04-12	0~200mm	EXPLOIT
T-03-S F001	Temperature Recorder	DR230	27CC360 02	2017-10-14	2018-10-14	-20℃-200 ℃	YOKOGAWA
T-03-S F371	hygrothermograph	N/A	N/A	2017-10-14	2018-10-14	N/A	N/A
T-03-S F169	Humidity Chamber	EL-10K A	9107726	2017-12-21	2018-12-21	-45℃-160 ℃, 20%RH-98 %RH	ESPEC
T-03-S F183	Stopwatch	PC396	N/A	2018-4-10	2019-4-10	0-3600s/3.0 s/d	TianFu
T-03-S F090	Roller fall off tester	GT	1#	NCR	NCR	0~90℃	Shenzhen De Mai Sheng
F-03-S F016	Circular Plane	N/A	N/A	NCR	NCR	30mm	N/A
F-03-S F385	AS/NZS 3112 figure2.9 2.10 pin temperature rise test device	AS/NZ S 3112 figure2. 9 2.10	N/A	2017-10-26	2018-10-26	N/A	N/A
F-03-S F383	AS/NZS 3112 figure2.5 indentation test	AS/NZ S 3112 figure2. 5	N/A	2017-10-26	2018-10-26	N/A	N/A
F-03-S F383	AS/NZS 3112 figure2.5 indentation test	AS/NZ S 3112 figure2. 5	N/A	2017-10-26	2018-10-26	N/A	N/A
F-03-S F384	AS/NZS 3112 figure2.7 pin bending test device	AS/NZ S 3112 figure2. 7	N/A	2017-10-26	2018-10-26	N/A	N/A

End of Report