



TEST REPORT

APPLICANT: GlobTek, Inc.
ADDRESS: 186 Veterans Dr. Northvale, NJ 07647 USA

REPORT NUMBER: 151200581SHA-001
DATE: 2015-12-18

SAMPLE DESCRIPTION : Detachable integral plug for power supplies

MODEL NO. : Q-SAA, Q-AU

TESTING LABORATORY : Intertek Testing Services Shanghai Limited.

ADDRESS : Building No.86, 1198 Qinzhou Road (North), Shanghai 200233, China

MANUFACTURER: GlobTek (Suzhou) Co., Ltd
Building 4, No. 76 JinLing East Road, Suzhou Industrial Park, Suzhou, JiangSu, 215021, China

TRADEMARK: 

RATING. : Input for power supply: 100-240VAC, 50-60Hz, 0.3A

DATE RECEIVED : 2015-12-08

DATE TEST CONDUCTED: 2015-12-08 to 2015-12-15

TEST REQUESTED : Test for compliance with Appendix J of AS/NZS 3112:2011+A1:2012+A2:2013

TEST METHOD : According to Appendix J of AS/NZS 3112:2011+A1:2012+A2:2013

REMARK : This test report is based on report 150601927SHA-001.

***** E N D *****

PREPARED BY:
FOR INTERTEK TESTING SERVICES
SHANGHAI LTD.

CHECKED BY:
FOR INTERTEK TESTING SERVICES
SHANGHAI LTD.

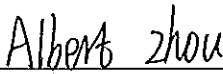
Albert Zhou
Engineer

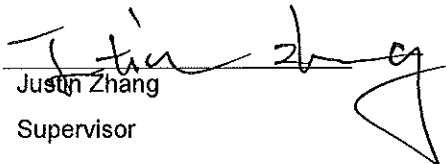
Justin Zhang
Supervisor

- . The test results reported in this test report shall refer only to the sample actually tested and shall not refer or be deemed to refer to bulk from which such a sample may be said to have been obtained.
- . This report shall not be reproduced except in full without prior authorization from Intertek Testing Services Shanghai Limited.
- . The services are provided subject to the terms and condition of the company, which can be furnished upon request.

Clause	Requirement – Test	Remark	Verdict
2.2	PLUG PINS		P
2.2.1	Material for pins		P
	Current carrying parts of plug pins -copper, or copper alloy containing at least 58% copper for parts made from cold rolled sheet or at least 50% copper for other parts; or stainless steel containing at least 13% chromium and not more than 0.09% carbon.	58% copper	P
2.2.2	Assembly of pins		P
2.2.3	The exposed ends and the contact portion of plug pins shall be smooth and free from openings or indentations;		P
2.2.4	Live parts of insulated pin plugs shall not be exposed when the plug is partially or fully engaged with the associated socket.		P
	Plugs with insulated pin do not need to comply with the R20.0 +/-1 mm of Figure 2.1(e).		P
2.8	RATINGS AND DIMENSIONS OF LOW VOLTAGE PLUGS		P
2.8.1	Low voltage flat-pin plugs shall conform to the appropriate dimensions shown in Figure 2.1.		P
	the distance between a live pin of any plug and the edge of the moulding of the plug, shall be not less than 9 mm.	9.38mm min.	P
	No point on the front face of the plug is more than 0.5 mm.	No protrusion	P
2.8.4	Compliance with dimensional requirements of Figure 2.1		P
	Low voltage flat-pin or combination of flat and round pin, plugs having ratings up to 15A of Figure 2.1(a1), Figure 2.1(c), Figure 2.1(d), Figure 2.1(f) or Figure 2.1(g) type shall comply with the dimensional requirements of Figure 2.1(e).		P
	Plugs with insulated pins, complying with this Standard, need not comply with dimension R20+/-1.0 mm of Figure 2.1(e)		P
2.9	INTERNAL CONNECTIONS		N/A
	A loose terminal screw or conductive material cannot bridge any live parts or earthing parts;		N/A
2.10	ARRANGEMENT OF EARTHING CONNECTIONS	No earthing pin	N/A
2.12	MARKING (No marking is applicable for the integral plug portion. See markings for transformer)		N/A
2.12.6	Configuration of plugs, viewed as from the pins, shall be earth, neutral and active in a clockwise direction. Where there is no earthing pin, the live pins shall conform to this configuration.		P
2.13	TESTS ON PLUGS		P

Clause	Requirement – Test	Remark	Verdict
2.13.2	Insulation resistance test	(See Table 1)	P
2.13.3	High voltage test	(See Table 1)	P
2.13.7	Mechanical strength of pin tests		P
2.13.7.1	Tumbling barrel test (modified as follows)		P
	a) 500 times if the mass of the specimen does not exceed 250g.	Approx 0.098kg. (See Table 3)	P
	b) 250 times if the mass of the specimen exceeds 250g.		N/A
	The pins being straightened after 100 drops and at the completion of the test to pass through the appropriate gauge of figure A1, B1 or F1; and following each test the samples shall comply with item (e) of standard): -the pins shall be inspected with normal, or corrected to normal, vision. Insulation may be removed if necessary. Pins shall not be broken or show cracking.		P
2.13.7.2	Pin bending test	(See Table 4)	P
	The point of application of the force shall be 14 ± 0.5 mm from the face of the plug.		P
	The direction of the force shall be along a line parallel to the face of the plug.		P
	Active and neutral pins shall be forced towards the centroid of the plug and then back to the starting point. Earth pin shall be forced but in one direction only then back to the starting point.		P
	The distance moved from the point of application shall be 7.5 ± 0.3 mm. Any "spring-back" is ignored.		P
	The travel from the starting point to the end point and back to the starting point is one cycle.		P
	The interval between successive cycles shall be a minimum of 10 s.		P
	The duration of one cycle shall be a maximum of 60 s.		P
	The pins shall be tested for 20 complete cycles.		P
	After to tests the pins shall be inspected with normal or corrected to normal vision.		P
	The pin shall not be broken off.		P
2.13.8	Temperature rise test (modified as follows)		P
	With 1.1 times rated current prescribed by transformer. The temperature rise of the terminals shall not exceed 45 K.	(See Table 5)	P
2.13.9	Securement of pins		P
2.13.9.1	Movement of pins		P

Clause	Requirement – Test	Remark	Verdict
	Clamped 5 ± 0.5 mm and applying 18 ± 1 N to the pin at 14 ± 0.5 mm		P
	The maximum deflection shall not exceed 2.0 mm.	(See Table 6)	P
2.13.9.2	Fixing of pins		P
	Maintained $50 \pm 2^\circ\text{C}$ for 1 h. 60 ± 0.6 N for 10 min.		P
	The attachment of pins shall be not more than 2.4 mm or if any pin fails to return to within 0.8 mm of its nominal length specified in Figure 2.1 within 5 min of the removal of the test force.	(See Table 7)	P
2.13.13	Tests on the insulation material of insulated pin plugs, if any		P
2.13.13.2	Pressure test at high temperature		P
	Maintained for 2 h at $160 \pm 5^\circ\text{C}$. Force applied through the blade: 2,5 N		P
	Thickness within the area of impression $\geq 50\%$. no cracks	(See Table 13)	P
2.13.13.3	Static damp heat test		P
	Two damp heat cycles (12+12h), 95% relative humidity, Lower temperature $25+3^\circ\text{C}$ and upper temperature 40°C		P
	(a) the insulation resistance test in accordance with Clause 2.13.2(e); (b) high voltage test in accordance with Clause 2.13.3 and; (c) abrasion test in accordance with Clause 2.13.13.6.		P
2.13.13.4	Low temperature test		P
	Maintained at $-15+2^\circ\text{C}$ for 24h and returned to room temperature		P
	(a) the insulation resistance test in accordance with Clause 2.13.2(e); (b) high voltage test in accordance with Clause 2.13.3 and; (c) abrasion test in accordance with Clause 2.13.13.6.		P
2.13.13.5	Impact test at low temperature		P
	Maintained at $-15 \pm 2^\circ\text{C}$ for at least 24 h. a height of 100 mm. Four impacts. No cracks.		P
2.13.13.6	Abrasion test		P
	Plug pins provided with insulating sleeves: 20000 movements, 4 N (apparatus shown in fig. 23). No damage, the insulating sleeve shall not have punctured or rucked up.		P
APPENDIX J	EQUIPMENT WITH INTEGRAL PINS FOR INSERTION INTO SOCKET-OUTLETS		P
J1	SCOPE		P
J2	REQUIREMENTS FOR THE PLUG PORTION		P

Clause	Requirement – Test	Remark	Verdict
J2.1	Plug portion		P
J2.2	Requirements		P
J2.2.1	General		
J2.2.2	Plug pins of plug portions	See clause 2.2	P
J2.2.3	Ratings and dimensions for low voltage plug portions	See clause 2.8	P
J2.2.4	Internal connection for plug portions	See clause 2.9	P
J2.2.5	Arrangement of earthing connection for plug portions	See clause 2.10	P
J2.2.6	Configuration of plug portions	See clause 2.12.6	P
J2.2.7	Tests	See clause 2.13	P
J2.2.7.1	General		P
J2.2.7.2	High voltage test	See clause 2.13.3	P
J2.2.7.3	Mechanical strength of pin tests	See clause 2.13.7	P
J2.2.7.3.1	Tumbling barrel test	See clause 2.13.7.1	P
J2.2.7.3.2	Pin bending test	See clause 2.13.7.2	P
J2.2.7.4	Temperature rise test	See clause 2.13.8	P
J2.2.7.5	Securement of pins of the plug portion	See clause 2.13.9	P
J2.2.7.6	Tests on the insulation material of insulated pin plug portions	See clause 2.13.13	P
J2.2.7.7	Equipment with integral pins intended to be supported by the contacts of a socket-outlet		P
	The additional torque, which has to be applied to socket-outlet to maintain the engagement face in the vertical plane, shall not exceed 0.25N.m.	Normal position: 0.096Nm; Reverse position: 0.094Nm	P
J2.3	Detachable plug portions		P
	compliance established by assessment with the plug portion fully assembled with the equipment	Tested with model GTM41134-0612 and GTM41078- 0605-USB as typical testing condition	P
	Access to live parts assessed for incorrect assembly of the plug portion	Live parts can't be accessible for incorrect assembly	P
	not possible to assemble the plug portion to the equipment resulting in a dangerous situation allowing access to live parts	The construction prevent from a dangerous situation	P
	The plug portion not expose live parts prior to assembly	The live parts are recessed for more than 6mm depth.	P

INSULATING MATERIALS TEST IN ACCORDANCE WITH AS/NZS 3121: 2002			
7.1	General		P
7.2	<p>Resistance to heat test</p> <p>The moulding shall be placed in an oven and maintained for 6 h at the temperature appropriate to its class (see Clause 5) plus 10°C.</p> <p>The temperature of the oven during this period shall not vary by more than ± 5°C. The moulding shall show no physical or chemical change likely to impair the safety of the equipment of which it forms a part.</p>		P
7.3	<p>Water absorption test</p> <p>The complete moulding shall be immersed in water at 20 °C ± 5°C for 48 h. The moulding shall not swell, delaminate, warp or show any physical change to a degree that would be liable to impair the safety of the equipment of which it forms a part.</p>		P
7.4	<p>Resistance to white spirit test</p> <p>Sample shall be immersed in white spirit at room temperature for 2 min.</p> <p>The moulding shall not blister, warp or show any physical or chemical change to a degree that would be liable to impair the safety of the equipment of which it forms a part.</p>		P

Table 1
RESULTS OF INSULATION RESISTANCE TEST AND HIGH VOLTAGE TEST

Tested parts	Insulation Resistance at 500V d.c. (required $\geq 5 \text{ M}\Omega$)	High voltage	
		Test voltage (V a.c.)	Failure?
(a) Between all poles of the plug, taken in pairs.	199 M Ω	1000 V a.c.	No
(b) Between live poles and any external metal, all live poles being connected together.	199 M Ω	3500 V a.c.	No
(c) Between live poles and earthing terminal metal of exposed metal, all live poles being connected together.	Not applicable	Not applicable	Not applicable
(d) Between live poles and accessible insulating part, all live poles being connected together.	199 M Ω	3500 V a.c.	No
(e) For insulated pin plugs, between live poles and a metal foil applied around the insulation on each live pin for a distance of approximately 4 mm from plug face, all live poles being connected.	199 M Ω	1250 V a.c.	No

Table 2 (Not applicable)
FLEXIBLE CORD ANCHORAGE TEST

Pull (N): 110			
Requirement	Test result (performed 3 times)		
The flexible cord can not part from the terminal.			
Displacement of flexible cable, mm (required $\leq 2\text{mm}$)			

Table 3
RESULT OF TUMBLING BARREL TEST

Requirement	Test result		
	Sample 1	Sample 2	Sample 3
After 1000 times of falls, the sample shall show no damage within the meaning of this standard.	OK	OK	OK
(a) Live parts shall not have become exposed to the standard test finger.	OK	OK	OK
(b) For earthing pin, the resistance of the plug/socket-outlet circuit shall be such that compliance with Clause 3.14.7 is maintained.	N/A	N/A	N/A
(c) Any other function affecting safety shall not be impaired.	OK	OK	OK
(d) No live part shall have become detached or loosened, to the extent that a hazardous situation is created.	OK	OK	OK

(e) The pins shall be inspected with normal, or corrected to normal, vision. Insulation may be removed if necessary. Pins shall not be broken or show cracking.	OK	OK	OK
---	----	----	----

Table 4
PIN BENDING TEST

Test condition: bend the pins with 20 cycles according to standard			
Requirement	Test result		
	Sample1	Sample2	Sample3
After the tests the pins shall be inspected with normal or corrected to normal vision. The pin shall not be broken off.	OK	OK	OK

Table 5
RESULT OF TEMPERATURE RISE TEST

Test current ($1.1 \times I_n$): 0.66A a.c.	
Tested part	Test result
Temperature rise on termination 1 (K):	6
Temperature rise on termination 2 (K):	6

Table 6
MOVEMENT OF PINS

Test condition: Preconditioned at 40°C for 1 h; Applied a force of 18 N gradually in 10 s and maintained for 10 s.	
Requirement	Test result
The maximum deflection shall not exceed 2.0 mm.	0.62 mm
The plug can still be inserted in the standard gauge shown in Appendix A.	OK

Table 7
FIXING OF PINS

Test condition: Heated to 50°C for 1 h; Applied a force of 60 N gradually in 10 s and maintained for 10 min.			
Requirement	Test result		
	Pin 1	Pin 2	Earthing Pin

Any pin shall not be displaced relative to the adjacent material of the body by more than 2.4 mm at any time during these tests	0.56 mm	0.58 mm	-
Any pin shall return to within 0.8 mm of its nominal length specified in Figure 2.1 (c) within 5 min of the removal of the test force	0.26 mm	0.31 mm	-

Table 8 (Not applicable)
GLOW WIRE TEST

Tested parts	Test temperature (°C)	Ignition of tissue paper?	Scorching of pinewood board?	Visible flame?	Extinguish within 30 s after removal of the glow wire?

Table 9 (Not applicable)
RESULT OF FIEXING TEST

Nominal cross-sectional area (mm ²):	
Weight of mass (N):	
All tested cord types:	
Requirement	Test result
During the test, no strands shall pierce the insulation so that they become accessible.	
After the test,	
(i) The sample shall not show damage.	
(ii) The protective sleeve, if any, shall not have separated from the body.	
(iii) The insulation of the flexible cord shall not have been damaged.	
(iv) Not more than 10% of the number of strands of each conductor shall have broken.	

Table 10 (Not applicable)
ATTACHMENT OF INSULATED CORES

Pull (N): 110	
Requirement	Test result
Any core shall not detach from the plug.	
The conductor strands shall not detach from a pin entirely at any time during the test.	

Table 11 (Not applicable)
ATTACHMENT OF SHEATHING

Pull (N): 130	
Requirement	Test result
The insulated cores shall not exposed at the point of entry to the plug or the cord guard.	

Table 12 (Not applicable)
ATTACHMENT OF CONDUCTORS

Pull (N): 85	
Requirement	Test result
The conductor strands shall not detach from the pin entirely during any test.	

Table 13
RESULT OF PRESSURE TEST AT HIGH TEMPERATURE

Test condition: heating at 160°C for 2h, applied a force of 25N through the blade to the specimen			
Requirement	Test result		
	Before test	After test	verdict
The thickness within the area of impression shall be not less than 50% of the thickness measured before the test.	0.36mm	0.27mm	OK
No cracks on the insulation material	OK	OK	OK
The dimension of the insulating material shall not have changed below the minimum size shown in fig2.4	1.61/6.30 /9.15mm	1.61/6.30 /9.15mm	OK

Table 14
STATIC DAMP HEAT TEST

Test condition: two damp heat cycles (12+12h), 95% relative humidity, Lower temperature 25 ₊₃ °C and upper temperature 40°C	
Requirement	Test result
after this treatment and after recovery to room temperature, this specimen shall be subjected to-	
(a) the insulation resistance test	OK
(b) high voltage test	OK
(c) abrasion test	OK

Table 15
LOW TEMPERATURE TEST

Test condition: maintained at -15 ₊₂ °C for 24h and returned to room temperature
--

Requirement	Test result
after this treatment and after recovery to room temperature, this specimen shall be subjected to-	
(a)the insulation resistance test	OK
(b)high voltage test	OK
(c)abrasion test	OK

Table 16
IMPACT TEST AT LOW TEMPERATURE

Test condition	Test result
Test temperature (°C): <u>-15</u> Duration: <u>24 hours</u>	
Requirement	
After the test the specimen shall show no damage within the meaning of this standard	OK

Table 17
ABRASION TEST

Test condition: 20000 movements,30 movements per min.	
Requirement	Test result
After the test,	
The pins shall show no damage which may affect safety or impair the further use of the plug	OK
The insulating sleeve shall not have punctured or rucked up.	OK

Table 18: Critical Component List

Object/ part No.	Manufacture/ trademark	Type/model	Technical data	Standard	Mark of conformity
Plug pin holder	SABIC INNOVATIVE PLASTICS B V	SE1X(GG)(f1)	V-1, 105°C	UL94	UL E45329
	SABIC INNOVATIVE PLASTICS B V	CX7211(GG)	V-0, 90°C	UL94	UL E45329
	SABIC INNOVATIVE PLASTICS B V	C2950	V-0, 75°C	UL94	UL E45329
	SABIC INNOVATIVE PLASTICS B V	945(GG)	V-0, 120°C	UL94	UL E45329

AS/NZS 3112:2011+A1:2012+A2:2013

Table 19

CHECKING OF DIMENSIONS

Dimensions checked by gauge and measurement			
Standard sheet Figure 2.1 (c)	Standard sheet Figure 2.1 (e)	Standard sheet Figure 2.1 (h)	
<p>(c) Two-pin plugs (up to 10 A, 250 V max.)</p>	<p>FIGURE 2.4 DIMENSIONS OF INSULATION ON INSULATED LIVE RING</p>		
For model GT*41134***** series			
Position	Required (mm)	By Measurement (mm) (Q-SAA / Q-AU)	By the gauge shown in Figure A1
A	6.35±0.15	6.35 / 6.36	-
B	6.35±0.15	-	-
C	1.63 ^{+0.15} _{-0.05}	1.62 / 1.66	-
D	7.92	-	OK
E	10.31	-	OK
F	17.06±0.4	17.17 / 16.93	-
G	19.94±0.8	-	-
R	0.35±0.05	0.32 / 0.34	-
S	0.90±0.10	0.84 / 0.88	-
T	≥0.60	-	-
V	6	-	OK
1	21.9 max. or 27.0 min.	21.14 / 52.55	-
2	21.9 max. or 27.0 min.	21.14 / 20.95	-
3	21.9 max. or 27.0 min.	52.81 / 20.77	-
4	21.9 max. or 27.0 min.	20.71 / 20.77	-
5	60°	-	OK
6	60°	-	OK
7	8.6 min.	10.47 / 10.89	-
8	21.0 max.	20.71 / 20.95	-
9	20.0±1.0	20.61 / 20.75	-
10	1.0 max	0.34 / 0.31	-
11	8.7±0.5	8.95 / 8.97	-

AS/NZS 3112:2011+A1:2012+A2:2013

Table 19 (Continued)

CHECKING OF DIMENSIONS

Dimensions checked by gauge and measurement

Standard sheet Figure 2.1 (c)

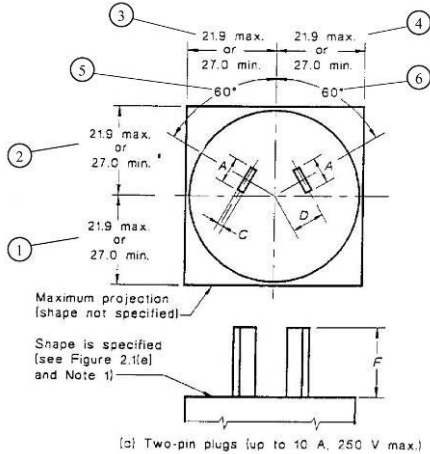

Standard sheet Figure 2.1 (e)

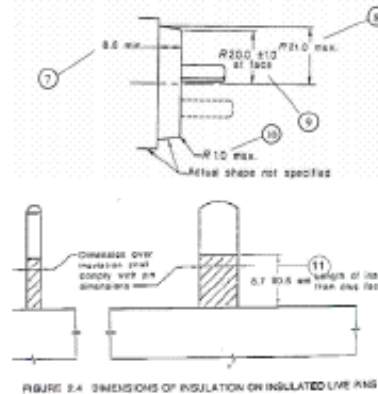

Standard sheet Figure 2.1 (h)

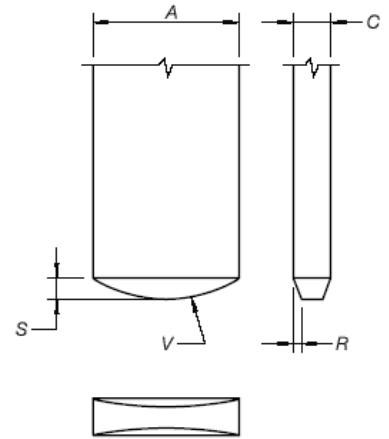

For model GT*46101-***-USB and GT*41078-*05-USB series

Position	Required (mm)	By Measurement (mm) (Q-SAA / Q-AU)	By the gauge shown in Figure A1
A	6.35±0.15	6.35 / 6.36	-
B	6.35±0.15	-	-
C	1.63 ^{+0.15} _{-0.05}	1.62 / 1.66	-
D	7.92	-	OK
E	10.31	-	OK
F	17.06±0.4	17.17 / 16.93	-
G	19.94±0.8	-	-
R	0.35±0.05	0.32 / 0.34	-
S	0.90±0.10	0.84 / 0.88	-
T	≥0.60	-	-
V	6	-	OK
1	21.9 max. or 27.0 min.	21.14 / 60.95	-
2	21.9 max. or 27.0 min.	21.14 / 20.95	-
3	21.9 max. or 27.0 min.	60.68 / 21.21	-
4	21.9 max. or 27.0 min.	20.65 / 21.21	-
5	60°	-	OK
6	60°	-	OK
7	8.6 min.	10.47 / 10.89	-
8	21.0 max.	20.75 / 20.95	-
9	20.0±1.0	20.61 / 20.75	-
10	1.0 max	0.34 / 0.31	-
11	8.7±0.5	8.95 / 8.97	-

Note: GT*46101-***-USB and GT*41078-*05-USB have the same enclosure.

Appendix 1: Photos of the products

Overall view for Q-SAA plug



Overall view for Q-AU plug



Internal view for Q-SAA plug and Q-AU plug (from left to right)



Internal view for Q-SAA plug and Q-AU plug (from left to right)

