



Test Report issued under the responsibility of:



TEST REPORT
IEC 60950-1
Information technology equipment – Safety –
Part 1: General requirements

Report Number: 160601646SHA-001
Date of issue.....: 2016-06-24
Total number of pages: 129 pages

Applicant's name: GlobTek, Inc.
Address: 186 Veterans Dr. Northvale, NJ 07647 USA

Test specification:

Standard: IEC 60950-1:2005 (Second Edition) + A1:2009 + A2:2013
Test procedure: CB Scheme
Non-standard test method.....: N/A

Test Report Form No.....: IEC60950_1F
Test Report Form(s) Originator: SGS Fimko Ltd
Master TRF.....: Dated 2014-02

Copyright © 2014 IEC System of Conformity Assessment Schemes for Electrotechnical Equipment and Components (IECEE System). All rights reserved.

This publication may be reproduced in whole or in part for non-commercial purposes as long as the IECEE is acknowledged as copyright owner and source of the material. IECEE takes no responsibility for and will not assume liability for damages resulting from the reader's interpretation of the reproduced material due to its placement and context.

If this Test Report Form is used by non-IECEE members, the IECEE/IEC logo and the reference to the CB Scheme procedure shall be removed.

This report is not valid as a CB Test Report unless signed by an approved CB Testing Laboratory and appended to a CB Test Certificate issued by an NCB in accordance with IECEE 02.

General disclaimer:

The test results presented in this report relate only to the object tested.
This report shall not be reproduced, except in full, without the written approval of the Issuing CB Testing Laboratory. The authenticity of this Test Report and its contents can be verified by contacting the NCB, responsible for this Test Report.

Test item description: ITE POWER SUPPLY

Trade Mark:  (G GlobTek, Inc.)

Manufacturer.....: Same as applicant

Model/Type reference: GT-43006-***-T*
(For the exact meaning of "***", please see general product information on page 7.)

Ratings: Input:100-240Vac, 50-60Hz, 1.0A
Output: 8-48Vdc, Max 5.06A

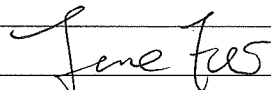
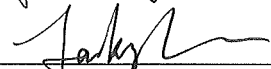
Testing procedure and testing location:		
<input checked="" type="checkbox"/>	CB Testing Laboratory:	Intertek Testing Services Shanghai
Testing location/ address		Building No. 86, 1198 Qinzhou Road (North), 200233 Shanghai, China
<input type="checkbox"/>	Associated CB Testing Laboratory:	
Testing location/ address		
Tested by (name + signature)		Jane Fei (Engineer) 
Approved by (name + signature)		Jacky Shu (Mandated Reviewer) 
<input type="checkbox"/>	Testing procedure: TMP/CTF Stage 1:	
Testing location/ address		
Tested by (name + signature)		
Approved by (name + signature)		
<input type="checkbox"/>	Testing procedure: WMT/CTF Stage 2:	
Testing location/ address		
Tested by (name + signature)		
Witnessed by (name + signature)		
Approved by (name + signature)		
<input type="checkbox"/>	Testing procedure: SMT/CTF Stage 3 or 4:	
Testing location/ address		
Tested by (name + signature)		
Witnessed by (name + signature)		
Approved by (name + signature)		
Supervised by (name + signature).....		

List of Attachments (including a total number of pages in each attachment):	
Page 61-80	: European group differences
Page 81-118	: National differences for Korea, Canada, United States of America, China, Australia and New Zealand, Japan.
Page 119-129	: Photos
Summary of testing:	
All tests are performed and the most disadvantageous results are recorded. We conclude that the appliances comply with this standard.	
Tests performed (name of test and test clause):	Testing location:
See test report.	Intertek Testing Services Shanghai
The equipment under test (EUT) fulfilled the test requirement according to the standard IEC 60950-1:2005 (Second Edition)+ A1: 2009 +A2:2013 and EN 60950-1:2006 + A11:2009 + A1:2010 + A12:2011 + A2:2013.	Building No. 86, 1198 Qinzhou Road (North), 200233 Shanghai, China
Summary of compliance with National Differences	
Group differences for the CENELEC countries, national Differences of Korea, Canada, United States of America, China, Australia and New Zealand, Japan have been checked.	
The product fulfils the requirements of IEC 60950-1:2005 (Second Edition) + A1:2009 + A2:2013 and EN 60950-1:2006 + A11:2009 + A1:2010 + A12:2011 + A2:2013.	

Copy of marking plate

The artwork below may be only a draft. The use of certification marks on a product must be authorized by the respective NCBs that own these marks.

(Additional requirements for markings. See 1.7 NOTE)

Class II label:

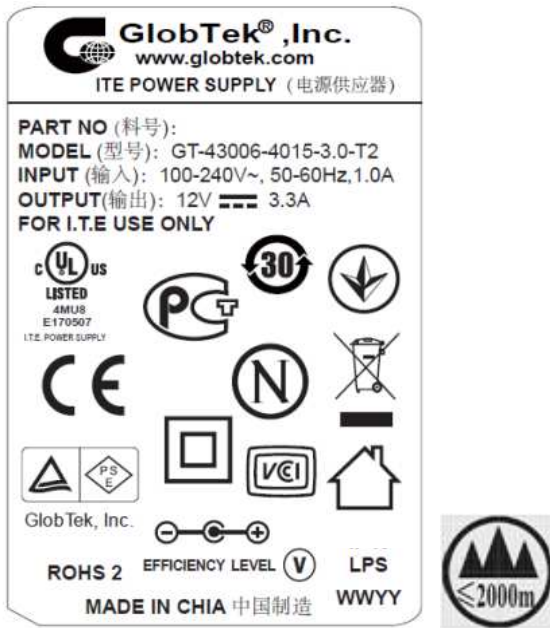

Note: Other Class II models have the same format of the marking plate but with respective output rating and model name.

Class I label:

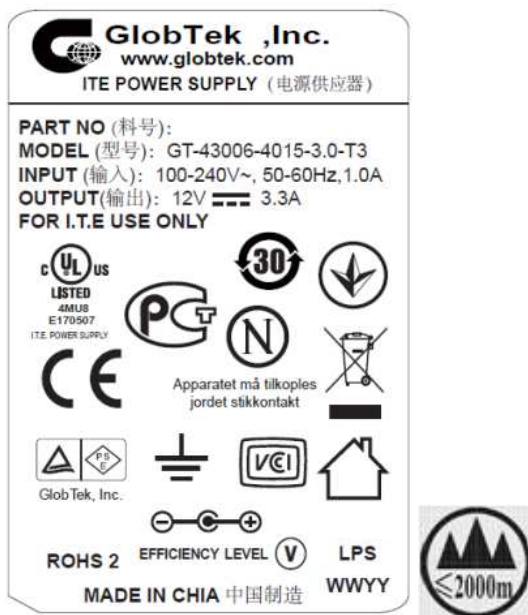

Note: Other Class I models have the same format of the marking plate but with respective output rating and model name.

Test item particulars:	
Equipment mobility:	<input checked="" type="checkbox"/> movable <input type="checkbox"/> hand-held <input type="checkbox"/> transportable <input type="checkbox"/> stationary <input type="checkbox"/> for building-in <input type="checkbox"/> direct plug-in
Connection to the mains:	<input checked="" type="checkbox"/> pluggable equipment <input checked="" type="checkbox"/> type A <input type="checkbox"/> type B <input type="checkbox"/> permanent connection <input checked="" type="checkbox"/> detachable power supply cord <input type="checkbox"/> non-detachable power supply cord <input type="checkbox"/> not directly connected to the mains
Operating condition:	<input checked="" type="checkbox"/> continuous <input type="checkbox"/> rated operating / resting time:
Access location	<input checked="" type="checkbox"/> operator accessible <input type="checkbox"/> restricted access location
Over voltage category (OVC)	<input type="checkbox"/> OVC I <input checked="" type="checkbox"/> OVC II <input type="checkbox"/> OVC III <input type="checkbox"/> OVC IV <input type="checkbox"/> other:
Mains supply tolerance (%) or absolute mains supply values	±10%
Tested for IT power systems	<input checked="" type="checkbox"/> Yes <input type="checkbox"/> No
IT testing, phase-phase voltage (V)	230 V
Class of equipment	<input checked="" type="checkbox"/> Class I or <input checked="" type="checkbox"/> Class II <input type="checkbox"/> Class III <input type="checkbox"/> Not classified
Considered current rating of protective device as part of the building installation (A)	16A (20A for Noth America)
Pollution degree (PD)	<input type="checkbox"/> PD 1 <input checked="" type="checkbox"/> PD 2 <input type="checkbox"/> PD 3
IP protection class	IPX0
Altitude during operation (m)	Max.2000m
Altitude of test laboratory (m)	Max.50m
Mass of equipment (kg)	Approx 0.471kg

Possible test case verdicts:	
- test case does not apply to the test object	N/A
- test object does meet the requirement.....	P (Pass)
- test object does not meet the requirement	F (Fail)
Testing:	
Date of receipt of test item	2016-06-12
Date(s) of performance of tests	2016-06-12 -2016-06-24

General remarks:

The test results presented in this report relate only to the object tested.
 This report shall not be reproduced, except in full, without the written approval of the Issuing testing laboratory.
 "(see Enclosure #)" refers to additional information appended to the report.
 "(see appended table)" refers to a table appended to the report.
 Throughout this report a comma / point is used as the decimal separator.
 Determination of the test result includes consideration of measurement uncertainty from the test equipment and methods.
 The samples submitted from for evaluation are representative of the products from each factory.

This report is for the exclusive use of Intertek's Client and is provided pursuant to the agreement between Intertek and its Client. Intertek's responsibility and liability are limited to the terms and conditions of the agreement. Intertek assumes no liability to any party, other than to the Client in accordance with the agreement, for any loss, expense or damage occasioned by the use of this report. Only the Client is authorized to permit copying or distribution of this report and then only in its entirety. Any use of the Intertek name or one of its marks for the sale or advertisement of the tested material, product or service must first be approved in writing by Intertek. The observations and test results in this report are relevant only to the sample tested. This report by itself does not imply that the material, product, or service is or has ever been under an Intertek certification program.

When determining the test conclusion, the Measurement Uncertainty of test has been considered.
 The samples submitted from for evaluation are representative of the products from each factory.

Manufacturer's Declaration per sub-clause 4.2.5 of IEC60950-1:

The application for obtaining a CB Test Certificate includes more than one factory location and a declaration from the Manufacturer stating that the sample(s) submitted for evaluation is (are) representative of the products from each factory has been provided

- Yes**
- Not applicable**

When differences exist; they shall be identified in the General product information section.

- Name and address of factory (ies)** :
1. GlobTek, Inc.
186 Veterans Dr. Northvale, NJ 07647 USA
 2. GlobTek (Suzhou) Co., Ltd.
Building 4, No. 76, Jin Ling East Rd., Suzhou Industrial Park, Suzhou, JiangSu 215021, China

General product information:

The equipment is a Class I (or Class II) power supply, intend for used with information technology equipment, there electronic component mount on PWB and housed in a thermoplastic enclosure by ultrasonic welding.

The equipment was submitted and evaluated for maximum manufacturer’s recommended ambient of 40°C.

Model difference:

All models have similar circuit schematic, components, critical components and also the similar construction are identical except for output rating, transformer(T1), minor secondary circuit, heat sink and classes of equipment(Class I or Class II).

Heat sink (HS1) for models with output 8~10V and 10.1~48V, they provided on BD1 and Q1 body, the different is the size.

Heat sink (HS2) for models with output 8~36V, it provided on D2 body.

Class I equipment: GT-43006-***-T3, GT-43006-***-T3A.

Class II equipment: GT-43006-***-T2.

Explanation of model designation GT-43006-*-T***

The 1st “*” denotes the rated output wattage, with a value of "1" to "40.5",

The 2nd “*” denotes the standard rated output voltage designation, with a value of "15", "24", "48",

The 3rd “*” is optional deviation, subtracted from standard output voltage, which can be “-0.1” to “-23.9” with interval of 0.1, or blank to indicate no voltage different,

The 2nd and 3rd together denote the output voltage, with a range of 8-48Vdc

The last “*” can be 2 or 3 or 3A, 2 means C8 inlet type, 3 means C14 inlet type, 3A means C6 inlet type.

The typical model designations and ratings are detailed as follows:

	Output Voltage	Max.Output Current	Max.Output Wattage
GT-43006-*15*-T*	8-15Vdc	5.06A	40.5W
GT-43006-*24*-T*	15.1-24Vdc	2.68A	40.5W
GT-43006-*48*-T*	24.1-48Vdc	1.68A	40.5W

Abbreviations used in the report:

- | | | | |
|--------------------------------------|-------------|----------------------------|--------------|
| - normal conditions | N.C. | - single fault conditions | S.F.C |
| - functional insulation | OP | - basic insulation | BI |
| - double insulation | DI | - supplementary insulation | SI |
| - between parts of opposite polarity | BOP | - reinforced insulation | RI |

Indicate used abbreviations (if any)

IEC 60950-1			
Clause	Requirement + Test	Result - Remark	Verdict

1	GENERAL		P
---	----------------	--	---

1.5	Components		P
1.5.1	General		P
	Comply with IEC 60950-1 or relevant component standard	(see appended tables 1.5.1)	P
1.5.2	Evaluation and testing of components		P
1.5.3	Thermal controls		N/A
1.5.4	Transformers	(see also Annex C)	P
1.5.5	Interconnecting cables		P
1.5.6	Capacitors bridging insulation	Approved X / Y capacitors (see appended table 1.5.1)	P
1.5.7	Resistors bridging insulation		P
1.5.7.1	Resistors bridging functional, basic or supplementary insulation	All resistors are after current fuses (FS1), there are only functional insulation.	P
1.5.7.2	Resistors bridging double or reinforced insulation between a.c. mains and other circuits	No such resistors provided.	N/A
1.5.7.3	Resistors bridging double or reinforced insulation between a.c. mains and antenna or coaxial cable	No such resistors provided.	N/A
1.5.8	Components in equipment for IT power systems		N/A
1.5.9	Surge suppressors	(see appended table 1.5.1)	P
1.5.9.1	General	Approved Varistor comply with Annex Q used in primary circuit (see appended table 1.5.1)	P
1.5.9.2	Protection of VDRs	A fuse is connected in series with VDR	P
1.5.9.3	Bridging of functional insulation by a VDR		P
1.5.9.4	Bridging of basic insulation by a VDR		N/A
1.5.9.5	Bridging of supplementary, double or reinforced insulation by a VDR		N/A

1.6	Power interface		P
1.6.1	AC power distribution systems		P
1.6.2	Input current	(see appended table 1.6.2)	P
1.6.3	Voltage limit of hand-held equipment		N/A
1.6.4	Neutral conductor		P

IEC 60950-1			
Clause	Requirement + Test	Result - Remark	Verdict
1.7	Marking and instructions		P
1.7.1	Power rating and identification markings		P
1.7.1.1	Power rating marking		P
	Multiple mains supply connections.....:		N/A
	Rated voltage(s) or voltage range(s) (V)	See page 1.	P
	Symbol for nature of supply, for d.c. only	DC symbol used	P
	Rated frequency or rated frequency range (Hz)	See page 1.	P
	Rated current (mA or A)	See page 1.	P
1.7.1.2	Identification markings		P
	Manufacturer's name or trade-mark or identification mark	See Page 1.	P
	Model identification or type reference	See page 1.	P
	Symbol for Class II equipment only	used for Class II model only.	P
	Other markings and symbols	Additional symbols or marking do not give rise to misunderstanding.	P
1.7.1.3	Use of graphical symbols		P
1.7.2	Safety instructions and marking	Adequate instructions provided.	P
1.7.2.1	General		P
1.7.2.2	Disconnect devices		P
1.7.2.3	Overcurrent protective device		N/A
1.7.2.4	IT power distribution systems	230V for Norway only.	P
1.7.2.5	Operator access with a tool		N/A
1.7.2.6	Ozone		N/A
1.7.3	Short duty cycles		N/A
1.7.4	Supply voltage adjustment		N/A
	Methods and means of adjustment; reference to installation instructions		N/A
1.7.5	Power outlets on the equipment		N/A
1.7.6	Fuse identification (marking, special fusing characteristics, cross-reference)	The "FS1" and "T2.5A, 250 V" are marked adjacent to the mains fuse	P
1.7.7	Wiring terminals		N/A

IEC 60950-1			
Clause	Requirement + Test	Result - Remark	Verdict

1.7.7.1	Protective earthing and bonding terminals	Class I models : the earth terminal is marked with standard earth symbol on the Inlet.	P
1.7.7.2	Terminals for a.c. mains supply conductors		N/A
1.7.7.3	Terminals for d.c. mains supply conductors		N/A
1.7.8	Controls and indicators		N/A
1.7.8.1	Identification, location and marking		N/A
1.7.8.2	Colours		N/A
1.7.8.3	Symbols according to IEC 60417		N/A
1.7.8.4	Markings using figures		N/A
1.7.9	Isolation of multiple power sources		N/A
1.7.10	Thermostats and other regulating devices		N/A
1.7.11	Durability	The label was subjected to the permanence of marking test. The label was rubbed with cloth for 15 s and then again for 15 s with the cloth soaked with HEXANE. After this test there was no damage to the label. The marking on the label did not fade. There was no curling or lifting of the label edge.	P
1.7.12	Removable parts	No markings on removable parts exist.	N/A
1.7.13	Replaceable batteries		N/A
	Language(s)		—
1.7.14	Equipment for restricted access locations.....		N/A

2	PROTECTION FROM HAZARDS		P
2.1	Protection from electric shock and energy hazards		P
2.1.1	Protection in operator access areas		P
2.1.1.1	Access to energized parts		P
	Test by inspection	All accessible circuits are SELV circuits.	P
	Test with test finger (Figure 2A)	The test finger was unable to contact bare hazardous parts, basic insulation, or ELV circuits.	P

IEC 60950-1			
Clause	Requirement + Test	Result - Remark	Verdict
	Test with test pin (Figure 2B)	The test pin was unable to contact bare hazardous parts.	P
	Test with test probe (Figure 2C)		N/A
2.1.1.2	Battery compartments	No battery compartments.	N/A
2.1.1.3	Access to ELV wiring	No ELV circuits.	N/A
	Working voltage (V _{peak} or V _{rms}); minimum distance through insulation (mm)		—
2.1.1.4	Access to hazardous voltage circuit wiring		N/A
2.1.1.5	Energy hazards	(see appended tables 2.1.1.5)	P
2.1.1.6	Manual controls		N/A
2.1.1.7	Discharge of capacitors in equipment		P
	Measured voltage (V); time-constant (s).....	Model No. GT-43006-4048-T2 Normal: 1.6;0.66 Model No. GT-43006-4048-T3 Normal: 1.5;0.66	—
2.1.1.8	Energy hazards – d.c. mains supply		N/A
	a) Capacitor connected to the d.c. mains supply ..		N/A
	b) Internal battery connected to the d.c. mains supply		N/A
2.1.1.9	Audio amplifiers		N/A
2.1.2	Protection in service access areas		N/A
2.1.3	Protection in restricted access locations		N/A

2.2	SELV circuits		P
2.2.1	General requirements		P
2.2.2	Voltages under normal conditions (V)	All accessible voltages are less than 42.4 V _p or 60 V dc and are classified as SELV.	P
2.2.3	Voltages under fault conditions (V)	Under fault conditions voltage never exceed 71 V _p and 120 Vdc and do not exceed 42.4 V _p or 60 Vdc for more than 0.2 sec.	P

IEC 60950-1			
Clause	Requirement + Test	Result - Remark	Verdict

2.2.4	Connection of SELV circuits to other circuits :	SELV circuits intend to be connected to SELV circuits only.	P
-------	-------------------------------------------------------	-------------------------------------------------------------	---

2.3	TNV circuits		N/A
2.3.1	Limits	No TNV circuits	N/A
	Type of TNV circuits..... :		—
2.3.2	Separation from other circuits and from accessible parts		N/A
2.3.2.1	General requirements		N/A
2.3.2.2	Protection by basic insulation		N/A
2.3.2.3	Protection by earthing		N/A
2.3.2.4	Protection by other constructions :		N/A
2.3.3	Separation from hazardous voltages		N/A
	Insulation employed :		—
2.3.4	Connection of TNV circuits to other circuits		N/A
	Insulation employed :		—
2.3.5	Test for operating voltages generated externally		N/A

2.4	Limited current circuits		P
2.4.1	General requirements	Worst case selected: Model NO. GT-43006-4048-T3 For bridging capacitor CY1 with 2200pF	P
2.4.2	Limit values	0.7mA	P
	Frequency (Hz) :	<1k	—
	Measured current (mA) :	0.0784mA	—
	Measured voltage (V)..... :	26.6V	—
	Measured circuit capacitance (nF or µF) :	<0.1µF	—
2.4.3	Connection of limited current circuits to other circuits	Output circuit as limited current circuit connected to other circuits.	P

2.5	Limited power sources		P
	a) Inherently limited output		P
	b) Impedance limited output		N/A

IEC 60950-1			
Clause	Requirement + Test	Result - Remark	Verdict
	c) Regulating network limited output under normal operating and single fault condition		P
	d) Overcurrent protective device limited output		N/A
	Max. output voltage (V), max. output current (A), max. apparent power (VA)	(see appended table 2.5)	—
	Current rating of overcurrent protective device (A) .:		—
	Use of integrated circuit (IC) current limiters		N/A
2.6	Provisions for earthing and bonding		P
2.6.1	Protective earthing	Class I model series were checked.	P
2.6.2	Functional earthing		P
	Use of symbol for functional earthing	Fuction earting is separated from hazardous voltage by reinforced insulation.	P
2.6.3	Protective earthing and protective bonding conductors		P
2.6.3.1	General		P
2.6.3.2	Size of protective earthing conductors		N/A
	Rated current (A), cross-sectional area (mm ²), AWG	Certified appliance inlet used.	—
	Size of protective bonding conductors		P
	Rated current (A), cross-sectional area (mm ²), AWG	1.0A, 0.75mm ² , 20AWG	—
	Protective current rating (A), cross-sectional area (mm ²), AWG	Not applicable	—
2.6.3.4	Resistance of earthing conductors and their terminations; resistance (Ω), voltage drop (V), test current (A), duration (min)	Model NO. GT-43006-4048-T3 5.25mΩ, 1V, 40A, 2mins	P
2.6.3.5	Colour of insulation	Green/yellow wiring is used. And the insulation tube pack the wiring.	P
2.6.4	Terminals		P
2.6.4.1	General		P
2.6.4.2	Protective earthing and bonding terminals		P
	Rated current (A), type, nominal thread diameter (mm)	Certified appliance inlet used.	—
2.6.4.3	Separation of the protective earthing conductor from protective bonding conductors		P
2.6.5	Integrity of protective earthing		P

IEC 60950-1			
Clause	Requirement + Test	Result - Remark	Verdict
2.6.5.1	Interconnection of equipment	Connection to other equipment: SELV only.	P
2.6.5.2	Components in protective earthing conductors and protective bonding conductors	No switches or fuses provided in earthing conductor.	P
2.6.5.3	Disconnection of protective earth	Certified appliance coupler is used.	P
2.6.5.4	Parts that can be removed by an operator	Certified appliance coupler.	P
2.6.5.5	Parts removed during servicing	No such parts.	N/A
2.6.5.6	Corrosion resistance		P
2.6.5.7	Screws for protective bonding		N/A
2.6.5.8	Reliance on telecommunication network or cable distribution system	No TNV circuits.	N/A

2.7	Overcurrent and earth fault protection in primary circuits		P
2.7.1	Basic requirements	Integral part of equipment	P
	Instructions when protection relies on building installation		N/A
2.7.2	Faults not simulated in 5.3.7		N/A
2.7.3	Short-circuit backup protection	Pluggabel Type A	P
2.7.4	Number and location of protective devices :	One current fuse (FS1) is located in the Line pole of primary circuit	P
2.7.5	Protection by several devices		N/A
2.7.6	Warning to service personnel :		N/A

2.8	Safety interlocks		N/A
2.8.1	General principles	No safety interlock used.	N/A
2.8.2	Protection requirements		N/A
2.8.3	Inadvertent reactivation		N/A
2.8.4	Fail-safe operation		N/A
	Protection against extreme hazard		N/A
2.8.5	Moving parts		N/A
2.8.6	Overriding		N/A
2.8.7	Switches, relays and their related circuits		N/A
2.8.7.1	Separation distances for contact gaps and their related circuits (mm) :		N/A

IEC 60950-1			
Clause	Requirement + Test	Result - Remark	Verdict
2.8.7.2	Overload test		N/A
2.8.7.3	Endurance test		N/A
2.8.7.4	Electric strength test		N/A
2.8.8	Mechanical actuators		N/A

2.9	Electrical insulation		P
2.9.1	Properties of insulating materials	No natural rubber, asbestos or hygroscopic material used.	P
2.9.2	Humidity conditioning	120 hours (considered the tropical conditions)	P
	Relative humidity (%), temperature (°C)	93 %, 40°C	—
2.9.3	Grade of insulation		P
2.9.4	Separation from hazardous voltages	SELV circuits separated from primary by double / reinforce insulation	P
	Method(s) used	Method 1.	—

2.10	Clearances, creepage distances and distances through insulation		P
2.10.1	General		P
2.10.1.1	Frequency	≤30kHz	P
2.10.1.2	Pollution degrees	Pollution degree 2	P
2.10.1.3	Reduced values for functional insulation	Refer sub-clause 5.3.4	P
2.10.1.4	Intervening unconnected conductive parts		N/A
2.10.1.5	Insulation with varying dimensions		N/A
2.10.1.6	Special separation requirements		N/A
2.10.1.7	Insulation in circuits generating starting pulses		N/A
2.10.2	Determination of working voltage		P
2.10.2.1	General		P
2.10.2.2	RMS working voltage	(see appended table 2.10.2)	P
2.10.2.3	Peak working voltage	(see appended table 2.10.2)	P
2.10.3	Clearances		P
2.10.3.1	General		P
2.10.3.2	Mains transient voltages		P
	a) AC mains supply	Overvoltage Category II	P
	b) Earthed d.c. mains supplies		N/A
	c) Unearthed d.c. mains supplies		N/A

IEC 60950-1			
Clause	Requirement + Test	Result - Remark	Verdict
	d) Battery operation		N/A
2.10.3.3	Clearances in primary circuits	(see appended table 2.10.3 and 2.10.4)	P
2.10.3.4	Clearances in secondary circuits	(see appended table 2.10.3 and 2.10.4)	P
2.10.3.5	Clearances in circuits having starting pulses		N/A
2.10.3.6	Transients from a.c. mains supply	1500Vp	P
2.10.3.7	Transients from d.c. mains supply		N/A
2.10.3.8	Transients from telecommunication networks and cable distribution systems		N/A
2.10.3.9	Measurement of transient voltage levels		N/A
	a) Transients from a mains supply		N/A
	For an a.c. mains supply		N/A
	For a d.c. mains supply		N/A
	b) Transients from a telecommunication network :		N/A
2.10.4	Creepage distances		P
2.10.4.1	General		P
2.10.4.2	Material group and comparative tracking index		P
	CTI tests	Material group IIIb is assumed to be used	—
2.10.4.3	Minimum creepage distances	(see appended table 2.10.3 and 2.10.4)	P
2.10.5	Solid insulation		P
2.10.5.1	General		P
2.10.5.2	Distances through insulation	(see appended table 2.10.5)	P
2.10.5.3	Insulating compound as solid insulation		N/A
2.10.5.4	Semiconductor devices		P
2.10.5.5	Cemented joints		N/A
2.10.5.6	Thin sheet material – General	Insulation tapes provided reinforced insulation on the core of transformer	P
2.10.5.7	Separable thin sheet material	(see appended table 2.10.5)	P
	Number of layers (pcs)	2	—
2.10.5.8	Non-separable thin sheet material		N/A
2.10.5.9	Thin sheet material – standard test procedure		N/A
	Electric strength test		—

IEC 60950-1			
Clause	Requirement + Test	Result - Remark	Verdict
2.10.5.10	Thin sheet material – alternative test procedure		P
	Electric strength test	(see appended table 2.10.5)	—
2.10.5.11	Insulation in wound components	(see Annex U)	P
2.10.5.12	Wire in wound components	Approved triple insulation wire for T1 secondary winding	P
	Working voltage	See 2.10.2	P
	a) Basic insulation not under stress		N/A
	b) Basic, supplementary, reinforced insulation	Meet the requirements.	P
	c) Compliance with Annex U	Meet the requirements.	P
	Two wires in contact inside wound component; angle between 45° and 90°	Insulation tape and/or tuing provided.	P
2.10.5.13	Wire with solvent-based enamel in wound components		N/A
	Electric strength test		—
	Routine test		N/A
2.10.5.14	Additional insulation in wound components		N/A
	Working voltage		N/A
	- Basic insulation not under stress		N/A
	- Supplementary, reinforced insulation		N/A
2.10.6	Construction of printed boards		P
2.10.6.1	Uncoated printed boards		P
2.10.6.2	Coated printed boards		N/A
2.10.6.3	Insulation between conductors on the same inner surface of a printed board		N/A
2.10.6.4	Insulation between conductors on different layers of a printed board		N/A
	Distance through insulation		N/A
	Number of insulation layers (pcs).....		N/A
2.10.7	Component external terminations		N/A
2.10.8	Tests on coated printed boards and coated components		N/A
2.10.8.1	Sample preparation and preliminary inspection		N/A
2.10.8.2	Thermal conditioning		N/A
2.10.8.3	Electric strength test		N/A
2.10.8.4	Abrasion resistance test		N/A

IEC 60950-1			
Clause	Requirement + Test	Result - Remark	Verdict
2.10.9	Thermal cycling		N/A
2.10.10	Test for Pollution Degree 1 environment and insulating compound		N/A
2.10.11	Tests for semiconductor devices and cemented joints	Approved optocouplers (U1)	P
2.10.12	Enclosed and sealed parts		N/A

3	WIRING, CONNECTIONS AND SUPPLY		P
3.1	General		P
3.1.1	Current rating and overcurrent protection		P
3.1.2	Protection against mechanical damage	(see appended table 1.5.1)	P
3.1.3	Securing of internal wiring		P
3.1.4	Insulation of conductors	All internal wirings are suitable fixed	P
3.1.5	Beads and ceramic insulators		N/A
3.1.6	Screws for electrical contact pressure		N/A
3.1.7	Insulating materials in electrical connections	No contact pressure-through insulation exists.	N/A
3.1.8	Self-tapping and spaced thread screws		N/A
3.1.9	Termination of conductors	All conductors are reliable secured.	P
	10 N pull test		P
3.1.10	Sleeving on wiring		N/A

3.2	Connection to a mains supply		P
3.2.1	Means of connection	Approved appliance inlet is provided.	P
3.2.1.1	Connection to an a.c. mains supply	An appliance inlet for connection of a detachable power supply cord	P
3.2.1.2	Connection to a d.c. mains supply		N/A
3.2.2	Multiple supply connections		N/A
3.2.3	Permanently connected equipment		N/A
	Number of conductors, diameter of cable and conduits (mm)		—
3.2.4	Appliance inlets		P
3.2.5	Power supply cords		N/A
3.2.5.1	AC power supply cords		N/A

IEC 60950-1			
Clause	Requirement + Test	Result - Remark	Verdict
	Type		—
	Rated current (A), cross-sectional area (mm ²), AWG		—
3.2.5.2	DC power supply cords		N/A
3.2.6	Cord anchorages and strain relief		N/A
	Mass of equipment (kg), pull (N)		—
	Longitudinal displacement (mm)		—
3.2.7	Protection against mechanical damage		N/A
3.2.8	Cord guards		N/A
	Diameter or minor dimension D (mm); test mass (g)		—
	Radius of curvature of cord (mm)		—
3.2.9	Supply wiring space		N/A

3.3	Wiring terminals for connection of external conductors		N/A
3.3.1	Wiring terminals		N/A
3.3.2	Connection of non-detachable power supply cords		N/A
3.3.3	Screw terminals		N/A
3.3.4	Conductor sizes to be connected		N/A
	Rated current (A), cord/cable type, cross-sectional area (mm ²)		—
3.3.5	Wiring terminal sizes		N/A
	Rated current (A), type, nominal thread diameter (mm)		—
3.3.6	Wiring terminal design		N/A
3.3.7	Grouping of wiring terminals		N/A
3.3.8	Stranded wire		N/A

3.4	Disconnection from the mains supply		P
3.4.1	General requirement		P
3.4.2	Disconnect devices	Approved appliance inlet is provided.	P
3.4.3	Permanently connected equipment		N/A
3.4.4	Parts which remain energized		N/A
3.4.5	Switches in flexible cords		N/A
3.4.6	Number of poles - single-phase and d.c. equipment		P

IEC 60950-1			
Clause	Requirement + Test	Result - Remark	Verdict

3.4.7	Number of poles - three-phase equipment		N/A
3.4.8	Switches as disconnect devices		N/A
3.4.9	Plugs as disconnect devices		N/A
3.4.10	Interconnected equipment		N/A
3.4.11	Multiple power sources	One power source only.	N/A

3.5	Interconnection of equipment		P
3.5.1	General requirements		P
3.5.2	Types of interconnection circuits	SELV circuit and Limited current circuits.	P
3.5.3	ELV circuits as interconnection circuits		N/A
3.5.4	Data ports for additional equipment		N/A

4	PHYSICAL REQUIREMENTS		P
4.1	Stability		N/A
	Angle of 10°	The mass of EUT is less than 7 kg	N/A
	Test force (N)	The mass of EUT is less than 25 kg and it is not floor-standing unit	N/A

4.2	Mechanical strength		P
4.2.1	General		P
	Rack-mounted equipment.		N/A
4.2.2	Steady force test, 10 N	The EUT is still complying with relevant requirements of this standard after 10 N force is applied to the components	P
4.2.3	Steady force test, 30 N		N/A
4.2.4	Steady force test, 250 N	The EUT is still complying with relevant requirements of this standard	P
4.2.5	Impact test		N/A
	Fall test		N/A
	Swing test		N/A
4.2.6	Drop test; height (mm)	750mm	P

IEC 60950-1			
Clause	Requirement + Test	Result - Remark	Verdict
4.2.7	Stress relief test	71.8°C,7h. all the enclosure materials listed in the table 1.5.1 are tested	P
4.2.8	Cathode ray tubes		N/A
	Picture tube separately certified		N/A
4.2.9	High pressure lamps		N/A
4.2.10	Wall or ceiling mounted equipment; force (N)		N/A

4.3	Design and construction		P
4.3.1	Edges and corners	No hazardous sharp edges or corners.	P
4.3.2	Handles and manual controls; force (N)		N/A
4.3.3	Adjustable controls		N/A
4.3.4	Securing of parts	No lossening of parts impairing cregage distances or clearances over supplementary or reinforced insulation is likely to occur.	N/A
4.3.5	Connection by plugs and sockets		N/A
4.3.6	Direct plug-in equipment		N/A
	Torque		—
	Compliance with the relevant mains plug standard		N/A
4.3.7	Heating elements in earthed equipment		N/A
4.3.8	Batteries		N/A
	- Overcharging of a rechargeable battery		N/A
	- Unintentional charging of a non-rechargeable battery		N/A
	- Reverse charging of a rechargeable battery		N/A
	- Excessive discharging rate for any battery		N/A
4.3.9	Oil and grease		N/A
4.3.10	Dust, powders, liquids and gases		N/A
4.3.11	Containers for liquids or gases		N/A
4.3.12	Flammable liquids		N/A
	Quantity of liquid (l)		N/A
	Flash point (°C)		N/A
4.3.13	Radiation		N/A

IEC 60950-1			
Clause	Requirement + Test	Result - Remark	Verdict
4.3.13.1	General		N/A
4.3.13.2	Ionizing radiation		N/A
	Measured radiation (pA/kg)		
	Measured high-voltage (kV)		—
	Measured focus voltage (kV)		—
	CRT markings		—
4.3.13.5.2	Light emitting diodes (LEDs)		—
4.3.13.3	Effect of ultraviolet (UV) radiation on materials		N/A
	Part, property, retention after test, flammability classification		N/A
4.3.13.4	Human exposure to ultraviolet (UV) radiation		N/A
4.3.13.5	Lasers (including laser diodes) and LEDs		N/A
4.3.13.5.1	Lasers (including laser diodes)		N/A
	Laser class		—
4.3.13.5.2	Light emitting diodes (LEDs)		—
4.3.13.6	Other types		N/A

4.4	Protection against hazardous moving parts		N/A
4.4.1	General	No hazardous moving parts	N/A
4.4.2	Protection in operator access areas		N/A
	Household and home/office document/media shredders		N/A
4.4.3	Protection in restricted access locations		N/A
4.4.4	Protection in service access areas		N/A
4.4.5	Protection against moving fan blades		N/A
4.4.5.1	General		N/A
	Not considered to cause pain or injury. a).....:		N/A
	Is considered to cause pain, not injury. b)		N/A
	Considered to cause injury. c)		N/A
4.4.5.2	Protection for users		N/A
	Use of symbol or warning		N/A
4.4.5.3	Protection for service persons		N/A
	Use of symbol or warning		N/A

IEC 60950-1			
Clause	Requirement + Test	Result - Remark	Verdict

4.5	Thermal requirements		P
4.5.1	General		P
4.5.2	Temperature tests		P
	Normal load condition per Annex L	L7	—
4.5.3	Temperature limits for materials	(see appended table 4.5)	P
4.5.4	Touch temperature limits	(see appended table 4.5)	P
4.5.5	Resistance to abnormal heat		N/A

4.6	Openings in enclosures		P
4.6.1	Top and side openings		P
	Dimensions (mm)	No opening.	—
4.6.2	Bottoms of fire enclosures		P
	Construction of the bottom, dimensions (mm) ..	No opening.	—
4.6.3	Doors or covers in fire enclosures		N/A
4.6.4	Openings in transportable equipment		N/A
4.6.4.1	Constructional design measures		N/A
	Dimensions (mm)		—
4.6.4.2	Evaluation measures for larger openings		N/A
4.6.4.3	Use of metallized parts		N/A
4.6.5	Adhesives for constructional purposes		N/A
	Conditioning temperature (°C), time (weeks).....		—

4.7	Resistance to fire		P
4.7.1	Reducing the risk of ignition and spread of flame	Comply with Method 1.	P
	Method 1, selection and application of components wiring and materials	(see appended table 4.7)	P
	Method 2, application of all of simulated fault condition tests		N/A
4.7.2	Conditions for a fire enclosure		P
4.7.2.1	Parts requiring a fire enclosure		P
4.7.2.2	Parts not requiring a fire enclosure		N/A
4.7.3	Materials		P
4.7.3.1	General		P
4.7.3.2	Materials for fire enclosures	(see appended table 1.5.1)	P

IEC 60950-1			
Clause	Requirement + Test	Result - Remark	Verdict
4.7.3.3	Materials for components and other parts outside fire enclosures		N/A
4.7.3.4	Materials for components and other parts inside fire enclosures	(see appended table 1.5.1)	P
4.7.3.5	Materials for air filter assemblies		N/A
4.7.3.6	Materials used in high-voltage components		N/A

5	ELECTRICAL REQUIREMENTS AND SIMULATED ABNORMAL CONDITIONS		P
5.1	Touch current and protective conductor current		P
5.1.1	General		P
5.1.2	Configuration of equipment under test (EUT)	Equipment designed for connection to only one power source.	P
5.1.2.1	Single connection to an a.c. mains supply		P
5.1.2.2	Redundant multiple connections to an a.c. mains supply		N/A
5.1.2.3	Simultaneous multiple connections to an a.c. mains supply		N/A
5.1.3	Test circuit		P
5.1.4	Application of measuring instrument		P
5.1.5	Test procedure		P
5.1.6	Test measurements		P
	Supply voltage (V)	(see appended table 5.1)	—
	Measured touch current (mA)	(see appended table 5.1)	—
	Max. allowed touch current (mA)	(see appended table 5.1)	—
	Measured protective conductor current (mA)	(see appended table 5.1)	—
	Max. allowed protective conductor current (mA)....	(see appended table 5.1)	—
5.1.7	Equipment with touch current exceeding 3,5 mA		N/A
5.1.7.1	General		N/A
5.1.7.2	Simultaneous multiple connections to the supply		N/A
5.1.8	Touch currents to telecommunication networks and cable distribution systems and from telecommunication networks		N/A
5.1.8.1	Limitation of the touch current to a telecommunication network or to a cable distribution system		N/A
	Supply voltage (V)		—
	Measured touch current (mA)		—

IEC 60950-1

Clause	Requirement + Test	Result - Remark	Verdict
	Max. allowed touch current (mA)		—
5.1.8.2	Summation of touch currents from telecommunication networks		N/A
	a) EUT with earthed telecommunication ports		N/A
	b) EUT whose telecommunication ports have no reference to protective earth		N/A

5.2	Electric strength		P
5.2.1	General	(see appended table 5.2)	P
5.2.2	Test procedure	No insulation breakdown detected during the test.	P

5.3	Abnormal operating and fault conditions		P
5.3.1	Protection against overload and abnormal operation	(see appended table 5.3)	P
5.3.2	Motors		N/A
5.3.3	Transformers	(see appended table 5.3 & Annex C)	P
5.3.4	Functional insulation.....	Methods a), c)	P
5.3.5	Electromechanical components		N/A
5.3.6	Audio amplifiers in ITE		N/A
5.3.7	Simulation of faults	(see appended table 5.3)	P
5.3.8	Unattended equipment		N/A
5.3.9	Compliance criteria for abnormal operating and fault conditions	No fire, molten metal or deformation during the tests. (See appended table 5.3)	P
5.3.9.1	During the tests	No fire, emission of molten metal or deformation was noted during the tests.	P
5.3.9.2	After the tests	After test, the EUT still complies with relevant requirements of this standard	P

6	CONNECTION TO TELECOMMUNICATION NETWORKS		N/A
6.1	Protection of telecommunication network service persons, and users of other equipment connected to the network, from hazards in the equipment		N/A
6.1.1	Protection from hazardous voltages		N/A
6.1.2	Separation of the telecommunication network from earth		N/A

IEC 60950-1			
Clause	Requirement + Test	Result - Remark	Verdict
6.1.2.1	Requirements		N/A
	Supply voltage (V)		—
	Current in the test circuit (mA)		—
6.1.2.2	Exclusions		N/A
6.2	Protection of equipment users from overvoltages on telecommunication networks		N/A
6.2.1	Separation requirements		N/A
6.2.2	Electric strength test procedure		N/A
6.2.2.1	Impulse test		N/A
6.2.2.2	Steady-state test		N/A
6.2.2.3	Compliance criteria		N/A
6.3	Protection of the telecommunication wiring system from overheating		N/A
	Max. output current (A)		—
	Current limiting method		—
7	CONNECTION TO CABLE DISTRIBUTION SYSTEMS		N/A
7.1	General		N/A
7.2	Protection of cable distribution system service persons, and users of other equipment connected to the system, from hazardous voltages in the equipment		N/A
7.3	Protection of equipment users from overvoltages on the cable distribution system		N/A
7.4	Insulation between primary circuits and cable distribution systems		N/A
7.4.1	General		N/A
7.4.2	Voltage surge test		N/A
7.4.3	Impulse test		N/A
A	ANNEX A, TESTS FOR RESISTANCE TO HEAT AND FIRE		N/A
A.1	Flammability test for fire enclosures of movable equipment having a total mass exceeding 18 kg, and of stationary equipment (see 4.7.3.2)		N/A
A.1.1	Samples		—
	Wall thickness (mm)		—

IEC 60950-1			
Clause	Requirement + Test	Result - Remark	Verdict
A.1.2	Conditioning of samples; temperature (°C)		N/A
A.1.3	Mounting of samples		N/A
A.1.4	Test flame (see IEC 60695-11-3)		N/A
	Flame A, B, C or D		—
A.1.5	Test procedure		N/A
A.1.6	Compliance criteria		N/A
	Sample 1 burning time (s).....		—
	Sample 2 burning time (s).....		—
	Sample 3 burning time (s).....		—
A.2	Flammability test for fire enclosures of movable equipment having a total mass not exceeding 18 kg, and for material and components located inside fire enclosures (see 4.7.3.2 and 4.7.3.4)		N/A
A.2.1	Samples, material		—
	Wall thickness (mm)		—
A.2.2	Conditioning of samples; temperature (°C)		N/A
A.2.3	Mounting of samples		N/A
A.2.4	Test flame (see IEC 60695-11-4)		N/A
	Flame A, B or C		—
A.2.5	Test procedure		N/A
A.2.6	Compliance criteria		N/A
	Sample 1 burning time (s).....		—
	Sample 2 burning time (s).....		—
	Sample 3 burning time (s).....		—
A.2.7	Alternative test acc. to IEC 60695-11-5, cl. 5 and 9		N/A
	Sample 1 burning time (s).....		—
	Sample 2 burning time (s).....		—
	Sample 3 burning time (s).....		—
A.3	Hot flaming oil test (see 4.6.2)		N/A
A.3.1	Mounting of samples		N/A
A.3.2	Test procedure		N/A
A.3.3	Compliance criterion		N/A
B	ANNEX B, MOTOR TESTS UNDER ABNORMAL CONDITIONS (see 4.7.2.2 and 5.3.2)		N/A

IEC 60950-1			
Clause	Requirement + Test	Result - Remark	Verdict
B.1	General requirements		N/A
	Position		—
	Manufacturer		—
	Type		—
	Rated values		—
B.2	Test conditions		N/A
B.3	Maximum temperatures		N/A
B.4	Running overload test		N/A
B.5	Locked-rotor overload test		N/A
	Test duration (days)		—
	Electric strength test: test voltage (V)		—
B.6	Running overload test for d.c. motors in secondary circuits		N/A
B.6.1	General		N/A
B.6.2	Test procedure		N/A
B.6.3	Alternative test procedure		N/A
B.6.4	Electric strength test; test voltage (V)		N/A
B.7	Locked-rotor overload test for d.c. motors in secondary circuits		N/A
B.7.1	General		N/A
B.7.2	Test procedure		N/A
B.7.3	Alternative test procedure		N/A
B.7.4	Electric strength test; test voltage (V)		N/A
B.8	Test for motors with capacitors		N/A
B.9	Test for three-phase motors		N/A
B.10	Test for series motors		N/A
	Operating voltage (V)		—

C	ANNEX C, TRANSFORMERS (see 1.5.4 and 5.3.3)		P
	Position	T1 (See appended table 1.5.1) on PCB	—
	Manufacturer	See appended table 1.5.1	—
	Type	See appended table 1.5.1	—
	Rated values	See appended table 1.5.1	—

IEC 60950-1			
Clause	Requirement + Test	Result - Remark	Verdict
	Method of protection	With circuit protection	—
C.1	Overload test	(see appended table 5.3)	P
C.2	Insulation	(see appended tables 5.2)	P
	Protection from displacement of windings	(see appended tables C.2)	P
D	ANNEX D, MEASURING INSTRUMENTS FOR TOUCH-CURRENT TESTS (see 5.1.4)		P
D.1	Measuring instrument		P
D.2	Alternative measuring instrument		N/A
E	ANNEX E, TEMPERATURE RISE OF A WINDING (see 1.4.13)		N/A
F	ANNEX F, MEASUREMENT OF CLEARANCES AND CREEPAGE DISTANCES (see 2.10 and Annex G)		P
G	ANNEX G, ALTERNATIVE METHOD FOR DETERMINING MINIMUM CLEARANCES		N/A
G.1	Clearances		N/A
G.1.1	General		N/A
G.1.2	Summary of the procedure for determining minimum clearances		N/A
G.2	Determination of mains transient voltage (V)		N/A
G.2.1	AC mains supply		N/A
G.2.2	Earthed d.c. mains supplies		N/A
G.2.3	Unearthed d.c. mains supplies		N/A
G.2.4	Battery operation		N/A
G.3	Determination of telecommunication network transient voltage (V)		N/A
G.4	Determination of required withstand voltage (V)		N/A
G.4.1	Mains transients and internal repetitive peaks		N/A
G.4.2	Transients from telecommunication networks		N/A
G.4.3	Combination of transients		N/A
G.4.4	Transients from cable distribution systems		N/A
G.5	Measurement of transient voltages (V)		N/A
	a) Transients from a mains supply		N/A
	For an a.c. mains supply		N/A

IEC 60950-1			
Clause	Requirement + Test	Result - Remark	Verdict
	For a d.c. mains supply		N/A
	b) Transients from a telecommunication network		N/A
G.6	Determination of minimum clearances		N/A
H	ANNEX H, IONIZING RADIATION (see 4.3.13)		N/A
J	ANNEX J, TABLE OF ELECTROCHEMICAL POTENTIALS (see 2.6.5.6)		P
	Metal(s) used	For Class I Models: Metal electrochemical potentials comply Table J.1.	—
K	ANNEX K, THERMAL CONTROLS (see 1.5.3 and 5.3.8)		N/A
K.1	Making and breaking capacity		N/A
K.2	Thermostat reliability; operating voltage (V)		N/A
K.3	Thermostat endurance test; operating voltage (V)		N/A
K.4	Temperature limiter endurance; operating voltage (V)		N/A
K.5	Thermal cut-out reliability		N/A
K.6	Stability of operation		N/A
L	ANNEX L, NORMAL LOAD CONDITIONS FOR SOME TYPES OF ELECTRICAL BUSINESS EQUIPMENT (see 1.2.2.1 and 4.5.2)		P
L.1	Typewriters	Not such type.	N/A
L.2	Adding machines and cash registers	Not such type.	N/A
L.3	Erasers	Not such type.	N/A
L.4	Pencil sharpeners	Not such type.	N/A
L.5	Duplicators and copy machines	Not such type.	N/A
L.6	Motor-operated files	Not such type.	N/A
L.7	Other business equipment	Continuous operation at rated output load.	P
M	ANNEX M, CRITERIA FOR TELEPHONE RINGING SIGNALS (see 2.3.1)		N/A
M.1	Introduction		N/A
M.2	Method A		N/A
M.3	Method B		N/A

IEC 60950-1			
Clause	Requirement + Test	Result - Remark	Verdict
M.3.1	Ringing signal		N/A
M.3.1.1	Frequency (Hz)		—
M.3.1.2	Voltage (V)		—
M.3.1.3	Cadence; time (s), voltage (V)		—
M.3.1.4	Single fault current (mA)		—
M.3.2	Tripping device and monitoring voltage		N/A
M.3.2.1	Conditions for use of a tripping device or a monitoring voltage		N/A
M.3.2.2	Tripping device		N/A
M.3.2.3	Monitoring voltage (V)		N/A
N	ANNEX N, IMPULSE TEST GENERATORS (see 1.5.7.2, 1.5.7.3, 2.10.3.9, 6.2.2.1, 7.3.2, 7.4.3 and Clause G.5)		N/A
N.1	ITU-T impulse test generators		N/A
N.2	IEC 60065 impulse test generator		N/A
P	ANNEX P, NORMATIVE REFERENCES		—
Q	ANNEX Q, Voltage dependent resistors (VDRs) (see 1.5.9.1)		P
	- Preferred climatic categories	Approved varistor is used	P
	- Maximum continuous voltage	(see appended table 1.5.1)	P
	- Combination pulse current	(see appended table 1.5.1)	P
	Body of the VDR Test according to IEC60695-11-5.....		N/A
	Body of the VDR. Flammability class of material (min V-1).....	V-0	P
R	ANNEX R, EXAMPLES OF REQUIREMENTS FOR QUALITY CONTROL PROGRAMMES		N/A
R.1	Minimum separation distances for unpopulated coated printed boards (see 2.10.6.2)		N/A
R.2	Reduced clearances (see 2.10.3)		N/A
S	ANNEX S, PROCEDURE FOR IMPULSE TESTING (see 6.2.2.3)		N/A
S.1	Test equipment		N/A
S.2	Test procedure		N/A

IEC 60950-1			
Clause	Requirement + Test	Result - Remark	Verdict
S.3	Examples of waveforms during impulse testing		N/A
T	ANNEX T, GUIDANCE ON PROTECTION AGAINST INGRESS OF WATER (see 1.1.2)		N/A
			—
U	ANNEX U, INSULATED WINDING WIRES FOR USE WITHOUT INTERLEAVED INSULATION (see 2.10.5.4)		P
		Certified source of triple insulated wire used in transformer (T1) See appended table 1.5.1	—
V	ANNEX V, AC POWER DISTRIBUTION SYSTEMS (see 1.6.1)		P
V.1	Introduction		P
V.2	TN power distribution systems		P
W	ANNEX W, SUMMATION OF TOUCH CURRENTS		N/A
W.1	Touch current from electronic circuits		N/A
W.1.1	Floating circuits		N/A
W.1.2	Earthed circuits		N/A
W.2	Interconnection of several equipments		N/A
W.2.1	Isolation		N/A
W.2.2	Common return, isolated from earth		N/A
W.2.3	Common return, connected to protective earth		N/A
X	ANNEX X, MAXIMUM HEATING EFFECT IN TRANSFORMER TESTS (see clause C.1)		N/A
X.1	Determination of maximum input current		N/A
X.2	Overload test procedure		N/A
Y	ANNEX Y, ULTRAVIOLET LIGHT CONDITIONING TEST (see 4.3.13.3)		N/A
Y.1	Test apparatus		N/A
Y.2	Mounting of test samples		N/A
Y.3	Carbon-arc light-exposure apparatus		N/A

IEC 60950-1			
Clause	Requirement + Test	Result - Remark	Verdict
Y.4	Xenon-arc light exposure apparatus		N/A
Z	ANNEX Z, OVERVOLTAGE CATEGORIES (see 2.10.3.2 and Clause G.2)		N/A
AA	ANNEX AA, MANDREL TEST (see 2.10.5.8)		N/A
BB	ANNEX BB, CHANGES IN THE SECOND EDITION		—
CC	ANNEX CC, Evaluation of integrated circuit (IC) current limiters		N/A
CC.1	General		N/A
CC.2	Test program 1.....		N/A
CC.3	Test program 2.....		N/A
CC.4	Test program 3.....		N/A
CC.5	Compliance.....		N/A
DD	ANNEX DD, Requirements for the mounting means of rack-mounted equipment		N/A
DD.1	General		N/A
DD.2	Mechanical strength test, variable N.....		N/A
DD.3	Mechanical strength test, 250N, including end stops.....		N/A
DD.4	Compliance.....		N/A
EE	ANNEX EE, Household and home/office document/media shredders		N/A
EE.1	General		N/A
EE.2	Markings and instructions		N/A
	Use of markings or symbols.....		N/A
	Information of user instructions, maintenance and/or servicing instructions.....		N/A
EE.3	Inadvertent reactivation test.....		N/A
EE.4	Disconnection of power to hazardous moving parts:		N/A
	Use of markings or symbols.....		N/A
EE.5	Protection against hazardous moving parts		N/A
	Test with test finger (Figure 2A)		N/A
	Test with wedge probe (Figure EE1 and EE2)		N/A

IEC 60950-1			
Clause	Requirement + Test	Result - Remark	Verdict

1.5.1	TABLE: List of critical components		P
-------	-------------------------------------------	--	---

Object/part No.	Manufacturer/ trademark	Type/model	Technical data	Standard (Edition / year)	Mark(s) of conformity ¹
Appliance inlet for Class I models(C6)	Zhejiang LECI Electronics Co., Ltd.	DB-6	2.5A, 250Vac	IEC/EN 60320-1	VDE 40032465
Alt.	Rich Bay Co., Ltd.	R-30790	2.5A, 250Vac	IEC/EN 60320-1	VDE 40030381
Alt.	Sun Fair Electric Wire & Cable (HK)Co. Ltd.	S-02	2.5A, 250Vac	IEC/EN 60320-1	VDE 40034448
Alt.	TECX-UNIONS Technology Corporation	TU-333 series	2.5A, 250Vac	IEC/EN 60320-1	ENEC 00633
Alt.	Rong Feng Industrial Co., Ltd.	RF-190	2.5A, 250Vac	IEC/EN 60320-1	VDE 40030379
Alt.	Inalways Corporation	0724	2.5A, 250Vac	IEC/EN 60320-1	ENEC 2010080
Alt.	Zhe Jiang Bei Er jia	ST-A04-002	2.5A, 250Vac	IEC/EN 60320-1	VDE 40016045
Appliance inlet for Class I models(C14)	Zhejiang LECI Electronics Co., Ltd.	DB-14	10A, 250Vac	IEC/EN 60320-1	VDE 40032137
Alt.	Rich Bay Co., Ltd.	R-301SN	10A, 250Vac	IEC/EN 60320-1	VDE 40030228
Alt.	Sun Fair Electric Wire & Cable (HK)Co. Ltd.	S-03	10A, 250Vac	IEC/EN 60320-1	VDE 40034447
Alt.	TECX-UNIONS Technology Corporation	TU-301-S, TU-301-SP	10A, 250Vac	IEC/EN 60320-1	ENEC 00647
Alt.	Rong Feng Industrial Co., Ltd.	SS-120	10A, 250Vac	IEC/EN 60320-1	VDE 40028101
Alt.	Inalways Corporation	0711 series	10A, 250Vac	IEC/EN 60320-1	ENEC 2010084

IEC 60950-1					
Clause	Requirement + Test			Result - Remark	Verdict
Object/part No.	Manufacturer/ trademark	Type/model	Technical data	Standard (Edition / year)	Mark(s) of conformity ¹
Alt.	Zhe Jiang Bei Er jia	ST-A01-003J	10A, 250Vac	IEC/EN 60320-1	VDE 40013388
Appliance inlet for Class II model (C8)	Zhejiang LECI Electronics Co., Ltd.	DB-8	2.5A, 250Vac	IEC/EN 60320-1	VDE 40032028
Alt.	Rich Bay Co., Ltd.	R-201SN90	2.5A, 250Vac	IEC/EN 60320-1	VDE 40030384
Alt.	Sun Fair Electric Wire & Cable (HK)Co. Ltd.	S-01	2.5A, 250Vac	IEC/EN 60320-1	VDE 40034449
Alt.	TECX-UNIONS Technology Corporation	SO-222 series	2.5A, 250Vac	IEC/EN 60320-1	VDE 40043268
Alt.	Rong Feng Industrial Co., Ltd.	RF-180	2.5A, 250Vac	IEC/EN 60320-1	VDE 40030168
Alt.	Inalways Corporation	0721 series	2.5A, 250Vac	IEC/EN 60320-1	ENEC 2010087
Alt.	Zhe Jiang Bei Er jia	ST-A03-005	2.5A, 250Vac	IEC/EN 60320-1	VDE 40014833
Earthing wire for Class I model	KUNSHAN NEW ZHICHENG ELECTRONICS TECHNOLOGIE S CO LTD	1015, 1007	Min. 20 AWG, Min. 300V, Min. 80°C	IEC/EN 60950-1	UL E237831 and tested in appliance
Alt.	ZHUANG SHAN CHUAN ELECTRICAL PRODUCTS (KUNSHAN) CO LTD	1015, 1007	Min. 20 AWG, Min. 300V, Min. 80°C	IEC/EN 60950-1	UL E333601 and tested in appliance
Alt.	DONGGUAN CHUANTAI WIRE PRODUCTS CO LTD	1015, 1007	Min. 20 AWG, Min. 300V, Min. 80°C	IEC/EN 60950-1	UL E315628 and tested in appliance
Alt.	YONG HAO ELECTRICAL INDUSTRY CO LTD	1015, 1007	Min. 20 AWG, Min. 300V, Min. 80°C	IEC/EN 60950-1	UL E240426 and tested in appliance

IEC 60950-1					
Clause	Requirement + Test			Result - Remark	Verdict
Object/part No.	Manufacturer/ trademark	Type/model	Technical data	Standard (Edition / year)	Mark(s) of conformity ¹⁾
Alt.	DONGGUAN GUNEETAL WIRE & CABLE CO LTD	1015, 1007	Min. 20 AWG, Min. 300V, Min. 80°C	IEC/EN 60950-1	UL E204204 and tested in appliance
Alt.	SHENG YU ENTERPRISE CO LTD	1015, 1007	Min. 20 AWG, Min. 300V, Min. 80°C	IEC/EN 60950-1	UL E219726 and tested in appliance
Alt.	KUNSHAN XINGHONGME NG ELECTRONIC CO LTD	1015, 1007	Min. 20 AWG, Min. 300V, Min. 80°C	IEC/EN 60950-1	UL E315421 and tested in appliance
PCB	WALEX ELECTRONIC (WUXI) CO LTD	T2A, T2B, T4	Min. 1.6 mm thickness, min. V-0, 130°C	IEC/EN 60950-1 UL 796	UL E154355 and tested in appliance
Alt.	CHEERFUL ELECTRONIC	03, 02, 03A	Min. 1.6 mm thickness, min. V-0, 130°C	IEC/EN 60950-1 UL 796	UL E199724 and tested in appliance
Alt.	BRITE PLUS ELECTRONICS (SUZHOU) CO LTD	DKV0-3A, DGV0-3A	Min. 1.6 mm thickness, min. V-0, 130°C	IEC/EN 60950-1 UL 796	UL E177671 and tested in appliance
Alt.	SHENZHEN TONGCHUANG XIN ELECTRONICS CO LTD	TCX	Min. 1.6 mm thickness, min. V-0, 130°C	IEC/EN 60950-1 UL 796	UL E250336 and tested in appliance
Alt.	GUANGDONG HETONG TECHNOLOGY CO LTD	CEM1, 2V0, FR4	Min. 1,6 mm thickness, min. V-0, 130°C	IEC 60335-1 UL 796	UL E243157 and tested in appliance
Alt.	DONGGUAN DAYSUN ELECTRONIC CO LTD	DS2	Min. 1,6 mm thickness, min. V-0, 130°C	IEC 60335-1 UL 796	UL E251754 and tested in appliance
Alt.	SHANGHAI AREX PRECISION ELECTRONIC CO LTD	02V0 04V0	Min. 1,6 mm thickness, min. V-0, 130°C	IEC 60335-1 UL 796	UL E186016 and tested in appliance

IEC 60950-1					
Clause	Requirement + Test		Result - Remark		Verdict
Object/part No.	Manufacturer/ trademark	Type/model	Technical data	Standard (Edition / year)	Mark(s) of conformity ¹⁾
Alt.	KUOTIANG ENT LTD	C-2 C-2A	Min. V-0, min 1.6 mm thickness, 130°C	IEC/EN 60950-1 UL 796	UL E227299 and tested in appliance
Alt.	PACIFIC WIN INDUSTRIAL LTD	PW-02 PW-03	Min. V-0, min 1.6 mm thickness, 130°C	IEC/EN 60950-1 UL 796	UL E228070 and tested in appliance
Alt.	Interchangeable	Interchangeable	Min. 1.6 mm thickness, min. V-0, 130°C	UL 796:2016	UL
Enclosure	SABIC INNOVATIVE PLASTICS B V	SE1X(GG)(F1)	Min. V-1, min.1.5 mm thickness, 105°C	IEC/EN 60950-1 UL 94 UL 746 A/B/C/D	UL E45329 and tested in appliance
Alt.	TEIJIN CHEMICALS LTD	LN-1250P, LN-1250G	Min. V-0 , min.1.5 mm thickness, 115°C	IEC/EN 60950-1 UL 94 UL 746 A/B/C/D	UL E50075 and tested in appliance
Alt.	SABIC INNOVATIVE PLASTICS B V	940	Min. V-1, min.1.5 mm thickness, 120°C	IEC/EN 60950-1 UL 94 UL 746 A/B/C/D	UL E45329 and tested in appliance
Alt.	ABIC INNOVATIVE PLASTICS B V	915R	Min. V-1 at 1.5 mm thickness, 120°C	IEC 60335-1 UL 94 UL 746 A/B/C/D	Tested within appliance UL E45329
Alt.	Interchangeable	Interchangeable	Min. V-1, min.1.5 mm thickness, 105°C	UL 94:2016	UL
Fuse (FS1)	Conquer Electronics Co., Ltd.	MST series	T2.5A, 250V	IEC/EN 60127-1 IEC/EN 60127-3	VDE 40017118
Alt.	Ever Island Electric Co., Ltd. And Walter Electric	2010 Serie(s)	T2.5A, 250V	IEC/EN 60127-1 IEC/EN 60127-3	VDE 40018781
Alt.	Bel Fuse Ltd.	RST-Serie(s)	T2.5A, 250V	IEC/EN 60127-1 IEC/EN 60127-3	VDE 40011144
Alt.	Cooper Bussmann LLC	SS-5	T2.5A, 250V	IEC/EN 60127-1 IEC/EN 60127-3	VDE 40015513

IEC 60950-1					
Clause	Requirement + Test			Result - Remark	Verdict
Object/part No.	Manufacturer/ trademark	Type/model	Technical data	Standard (Edition / year)	Mark(s) of conformity ¹⁾
Alt.	Dongguan Better	932	T2.5A, 250V	IEC/EN 60127-1 IEC/EN 60127-3	VDE 40033369
Alt.	Interchangeable	Interchangeable	T2.5A, 250V	IEC/EN 60127-1:2015 IEC/EN 60127-3:2015	S, VDE or other EU certification marks
X capacitor (CX1) (optional)	Cheng Tung Industrial Co., Ltd.	CTX	Max 0.22 μ F, Min.250V,100 $^{\circ}$ C, X1 or X2	IEC/EN 60384-14	VDE 40022642
Alt.	Tenta Electric Industrial Co. Ltd.	MEX	Max 0.22 μ F, Min.250V, 100 $^{\circ}$ C, X1 or X2	IEC/EN 60384-14	VDE 119119
Alt.	Joey Electronics (Dong Guan) Co., Ltd.	MPX	Max 0.22 μ F, Min.250V, 100 $^{\circ}$ C, X1 or X2	IEC/EN 60384-14	VDE 40032481
Alt.	Ultra Tech Xiphi Enterprise Co. Ltd.	HQX	Max 0.22 μ F, Min.250V, 100 $^{\circ}$ C, X1 or X2	IEC/EN 60384-14	VDE 40015608
Alt.	Xiangtai Electronic (Shenzhen) Co., Ltd.	MKP/MPX	Max 0.22 μ F, Min.250V, 100 $^{\circ}$ C, X1 or X2	IEC/EN 60384-14	VDE 40036065
Alt.	Carli Electronics Co., Ltd.	MPX	Max 0.22 μ F, Min.250V, 100 $^{\circ}$ C, X1 or X2	IEC/EN 60384-14	VDE 40008520
Alt.	Dain Electronics Co., Ltd.	MEX, MPX, NPX	Max 0.22 μ F, Min.250V, 100 $^{\circ}$ C, X1 or X2	IEC/EN 60384-14	VDE 40018798
Alt.	Interchangeable	Interchangeable	Max 0.22 μ F, Min.250V,100 $^{\circ}$ C, X1 or X2	IEC/EN 60384-14:2016	S, VDE or other EU certification marks
Y capacitor (CY1) (optional)	TDK-EPC Corporation, Capacitors Group Circuit Devices Business Group	CD	Min.250V, Min.125 $^{\circ}$ C, Y1, Max.2200pF	IEC/EN 60384-14	VDE 40029780
Alt.	Success Electronics Co., Ltd.	SB	Min.250V, Min.125 $^{\circ}$ C, Y1, Max.2200pF	IEC/EN 60384-14	VDE 40037221

IEC 60950-1					
Clause	Requirement + Test		Result - Remark		Verdict
Object/part No.	Manufacturer/ trademark	Type/model	Technical data	Standard (Edition / year)	Mark(s) of conformity ¹
Alt.	Success Electronics Co., Ltd.	SE	Min.250V, Min.125°C, Y1, Max.2200pF	IEC/EN 60384- 14	VDE 40037211
Alt.	Walsin Technology Corp.	AH	Min.250V, Min.125°C, Y1, Max.2200pF	IEC/EN 60384- 14	VDE 40001804
Alt.	Haohua Electronic Co.	CT 7	Min.250V, Min.125°C, Y1, Max.2200pF	IEC/EN 60384- 14	VDE 40003902
Alt.	Xiangtai Electronic (Shenzhen) Co., Ltd.	YO-series	Min.250V, Min.125°C, Y1, Max.2200pF	IEC/EN 60384- 14	VDE 40036880
Alt.	Interchangeable	Interchangeable	Min.250V, Min.125°C, Y1, Max.2200pF	IEC/EN 60384- 14: 2016	S, VDE or other EU certification marks
Photo Coupler (U1)	Everlight Electronics Co., Ltd.	EL817	Dti=0.5mm Int. , dcr=6.0mm EXT.dcr=7.7mm, thermal cycling test,110°C	IEC/EN 60747- 5-2	VDE 132249
Alt.	COSMO Electronics Corporation	K1010, KP1010	Dti=0.6mm Int. , Dcr = 4.0mm, Ext.dcr=5.0mm, thermal cycling test,115°C	IEC/EN 60747- 5-2	VDE 101347
Alt.	Lite-On Technology Corporation	LTV-817	Dti=0.8mm, EXT.dcr=7.8mm, thermal cycling test,100°C	IEC/EN 60747- 5-2	VDE 40015248
Alt.	Fairchild Semiconductor Pte Ltd	H11A817B, FOD817B	Insulation voltage: 850V, Transient overvoltage: 6000V; CTI175; Int. Cr/ Ext. Cr: ≥7.0/ 7.0 mm; 30/110/21	IEC/EN 60747- 5-2	VDE 40026857

IEC 60950-1					
Clause	Requirement + Test			Result - Remark	Verdict
Object/part No.	Manufacturer/ trademark	Type/model	Technical data	Standard (Edition / year)	Mark(s) of conformity ¹
Alt.	Sharp Corporation Electronic Components and Devices Group	PC817	Insulation voltage: 890V; Transient overvoltage: 9000V Int. Cr/ Ext. Cr: 7.62/ 7.62 mm; 30/100/21	IEC/EN 60747-5-2	VDE 40008087
Alt.	Bright Led Electronics Corp.	BPC-817 (A; B; C; D; L), BPC-817 M, BPC-817 S	Dti=0.4mm, EXT.dcr=7.0mm, thermal cycling test,100 °C	IEC/EN 60747-5-2	VDE 40007240
Alt.	Renesas	PS2561-1	Dti=0.4mm, EXT.dcr=7.0mm, thermal cycling test,100 °C	IEC/EN 60747-5-2	VDE 40008862
Varistor (MOV1) (optional)	JOYIN CO LTD	10N471K, 14N471K	Max continuous voltage: 300VAC, 6kV/3kA, 40/85/56	IEC/EN 61051-2 IEC/EN 60950-1	VDE 005937 & tested with appliance
Alt.	CENTRA SCIENCE CORP	CNR-10D471K, CNR-14D471K	Max continuous voltage: 300VAC, 6kV/3kA, 40/85/56	IEC/EN 61051-2 IEC/EN 60950-1	VDE 40008220 & tested with appliance
Alt.	THINKING ELECTRONIC INDUSTRIAL CO LTD	TVR10471K, TVR14471K	Max continuous voltage: 300VAC, 6kV/3kA, 40/85/56	IEC/EN 61051-2 IEC/EN 60950-1	VDE 005944 & tested with appliance
Alt.	SUCCESS ELECTRONICS CO LTD	SVR10D471K, SVR14D471K	Max continuous voltage: 300VAC, 6kV/3kA, 40/85/56	IEC/EN 61051-2 IEC/EN 60950-1	VDE 40030401 & tested with appliance
Alt.	CERAMATE TECHNICAL CO LTD	GNR10D471K, GND14D471K	Max continuous voltage: 300VAC, 6kV/3kA, 40/85/56	IEC/EN 61051-2 IEC/EN 60950-1	VDE 40031745 & tested with appliance
Alt.	BRIGHTKING (SHENZHEN) CO LTD	10D471K, 14D471K	Max continuous voltage: 300VAC, 6kV/3kA, 40/85/56	IEC/EN 61051-2 IEC/EN 60950-1	VDE 40027827 & tested with appliance

IEC 60950-1					
Clause	Requirement + Test			Result - Remark	Verdict
Object/part No.	Manufacturer/ trademark	Type/model	Technical data	Standard (Edition / year)	Mark(s) of conformity ¹
Alt.	LIEN SHUN ELECTRONICS CO LTD	10D471K, 14D471K	Max continuous voltage: 300VAC, 6kV/3kA, 40/85/56	IEC/EN 61051-2 IEC/EN 60950-1	VDE 40005858 & tested with appliance
Alt.	HONGZHI ENTERPRISES LTD	HEL- 10D471K, HEL-14D471K	Max continuous voltage: 300VAC, 6kV/3kA, 40/85/56	IEC/EN 61051-2 IEC/EN 60950-1	VDE 40008621 & tested with appliance
Alt.	GUANGXI NEW FUTURE INFORMATION INDUSTRY CO LTD	10D471K , 14D471K	Max continuous voltage: 300VAC, 6kV/3kA, 40/85/56	IEC/EN 61051-2 IEC/EN 60950-1	VDE 40030322 & tested with appliance
Insulating tape wrapping around the heatsink	3M COMPANY ELECTRICAL MARKETS DIV (EMD)	1350F-1 1350T-1	Min.130°C	IEC/EN 60950-1 UL 510	Tested with appliance UL E17385
Alt.	BONDTEC PACIFIC CO LTD	370S	Min.130°C	IEC/EN 60950-1 UL 510	Tested with appliance UL E175868
Alt.	JINGJIANG YAHUA PRESSURE SENSITIVE GLUE CO LTD	PZ CT	Min.130°C	IEC/EN 60950-1 UL 510	Tested with appliance UL E165111
Alt.	JINGJIANG JINGYI ADHESIVE PRODUCT CO LTD	JY25-A	Min.130°C	IEC/EN 60950-1 UL 510	Tested with appliance UL E246950
Alt.	CHANG SHU LIANG YI TAPE INDUSTRY CO LTD	LY-XX	Min.130°C	IEC/EN 60950-1 UL 510	Tested with appliance UL E246820
Transformer (T1) for models from 8V to17.9V	GlobTek BOAM Haopuwei	XF00739(8V- 17.9V)	Class E	IEC/EN 60950-1	Tested in appliance

IEC 60950-1					
Clause	Requirement + Test		Result - Remark		Verdict
Object/part No.	Manufacturer/ trademark	Type/model	Technical data	Standard (Edition / year)	Mark(s) of conformity ¹⁾
Transformer (T1) for models from 18V to 24V	GlobTek BOAM Haopuwei	XF00740(18V-24V)	Class E	IEC/EN 60950-1	Tested in appliance
Transformer (T1) for models from 24.1V to 48V	GlobTek BOAM Haopuwei	XF00743(24.1V-48V)	Class E	IEC/EN 60950-1	Tested in appliance
- Magnet wire	PACIFIC ELECTRIC WIRE & CABLE (SHENZHEN) CO LTD	UEWN/U, UEWS/U	130 °C	IEC/EN 60950-1 UL 1446	UL E201757 and tested in appliance
Alt.	JUNG SHING WIRE CO LTD	UEW-4, UEY-2	130°C	IEC/EN 60950-1 UL 1446	UL E174837 and tested in appliance
Alt.	JIANGSU HONGLIU MAGNET WIRE TECHNOLOGY CO LTD	2UEW/130	130°C	IEC/EN 60950-1 UL 1446	UL E335065 and tested in appliance
Alt.	CHANGZHOU DAYANG WIRE & CABLE CO LTD	2UEW/130	130°C	IEC/EN 60950-1 UL 1446	UL E158909 and tested in appliance
Alt.	WUXI JUFENG COMPOUND LINE CO LTD	2UEWB	130°C	IEC/EN 60950-1 UL 1446	UL E206882 and tested in appliance
Alt.	JIANGSU DARTONG M & E CO LTD	UEW	130°C	IEC/EN 60950-1 UL 1446	UL E237377 and tested in appliance
Alt.	SHANDONG SAINT ELECTRIC CO LTD	UEW/130	130°C	IEC/EN 60950-1 UL 1446	UL E194410 and tested in appliance
Alt.	ZHEJIANG LANGLI ELECTRIC EQUIPMENTS CO LTD	UEW	130°C	IEC/EN 60950-1 UL 1446	UL E222214 and tested in appliance

IEC 60950-1					
Clause	Requirement + Test			Result - Remark	Verdict
Object/part No.	Manufacturer/ trademark	Type/model	Technical data	Standard (Edition / year)	Mark(s) of conformity ¹
-Triple-insulated wire (Secondary)	GREAT LEOFLON INDUSTRIAL CO.,LTD.	TRW (B)	130°C	IEC/EN 60950-1 UL2353, UL746A	UL E211989 and tested in appliance
-Alt.	COSMOLINK CO LTD	TIW-M	130°C	IEC/EN 60950-1 UL2353, UL746A	UL E213764 and tested in appliance
-Alt.	FURUKAWA ELECTRIC CO LTD	TEX-E	130°C	IEC/EN 60950-1 UL2353, UL746A	UL E206440 and tested in appliance
-Alt.	CHANGYUAN ELECTRONICS (SHENZHEN) CO LTD	CB-TIW	130°C	IEC/EN 60950-1 UL2353, UL746A	UL E249037 and tested in appliance
-Alt.	SHENZHEN JIUDING NEW MATERIAL CO LTD	DTIW-B	130°C	IEC/EN 60950-1 UL2353, UL746A	UL E357999 and tested in appliance
-Bobbin	CHANG CHUN PLASTICS CO LTD	T375J, T375HF	V-0, 150°C, thickness 0.45 mm min.	IEC/EN 60950-1 UL 94	UL E59481 and tested in appliance
-Alt.	SUMITOMO BAKELITE CO LTD	PM-9820	V-0, 150°C, thickness 0.45 mm min.	IEC/EN 60950-1 UL 94	UL E41429 and tested in appliance
-Alt.	HITACHI CHEMICAL CO LTD	CP-J-8800	V-0, 150°C, thickness 0.45 mm min.	IEC/EN 60950-1 UL 94	UL E42956 and tested in appliance
-Insulating tape	3M COMPANY ELECTRICAL MARKETS DIV (EMD)	1350F-1, 1350T-1, 44	Min.130°C	IEC/EN 60950-1 UL 510	UL E17385 and tested in appliance
-Alt.	BONDTEC PACIFIC CO LTD	370S	Min.130°C	IEC/EN 60950-1 UL 510	UL E175868 and tested in appliance
-Alt.	JINGJIANG YAHUA PRESSURE SENSITIVE GLUE CO LTD	PZ, CT	Min.130°C	IEC/EN 60950-1 UL 510	UL E165111 and tested in appliance

IEC 60950-1					
Clause	Requirement + Test			Result - Remark	Verdict
Object/part No.	Manufacturer/ trademark	Type/model	Technical data	Standard (Edition / year)	Mark(s) of conformity ¹⁾
-Alt.	JINGJIANG JINGYI ADHESIVE PRODUCT CO LTD	JY25-A	Min.130°C	IEC/EN 60950-1 UL 510	UL E246950 and tested in appliance
-Alt.	CHANG SHU LIANG YI TAPE INDUSTRY CO LTD	LY-XX	Min.130°C	IEC/EN 60950-1 UL 510	UL E246820 and tested in appliance
Note: *. The product choose the transformer as its output voltage. 1. An asterisk indicates a mark that assures the agreed level of surveillance. 2. All transformer under all manufactures.					

1.6.2	TABLE: Electrical data (in normal conditions)	P
--------------	------------------------------------------------------	----------

U (V)	I (A)	Irated (A)	P (W)	Fuse #	Ifuse (A)	Condition/status
Model: GT-43006-4008-T3						
90 V (50 Hz)	0.88	--	44.3	FS1	0.88	Normal operating conditions.
90 V (60 Hz)	0.89	--	44.4	FS1	0.89	Normal operating conditions.
100 V (50 Hz)	0.80	1	44.2	FS1	0.80	Normal operating conditions.
100 V (60 Hz)	0.81	1	44.2	FS1	0.81	Normal operating conditions.
240 V (50 Hz)	0.38	1	43.8	FS1	0.38	Normal operating conditions.
240 V (60 Hz)	0.39	1	43.9	FS1	0.39	Normal operating conditions.
264 V (50 Hz)	0.36	--	43.7	FS1	0.36	Normal operating conditions.
264 V (60 Hz)	0.36	--	44.4	FS1	0.36	Normal operating conditions.

IEC 60950-1			
Clause	Requirement + Test	Result - Remark	Verdict

U (V)	I (A)	Irated (A)	P (W)	Fuse #	Ifuse (A)	Condition/status
Model: GT-43006-4048-T3						
90 V (50 Hz)	0.85	--	43.9	FS1	0.85	Normal operating conditions.
90 V (60 Hz)	0.87	--	44.0	FS1	0.87	Normal operating conditions.
100 V (50 Hz)	0.78	1	43.6	FS1	0.78	Normal operating conditions.
100 V (60 Hz)	0.81	1	43.7	FS1	0.81	Normal operating conditions.
240 V (50 Hz)	0.44	1	42.9	FS1	0.44	Normal operating conditions.
240 V (60 Hz)	0.44	1	42.9	FS1	0.44	Normal operating conditions.
264 V (50 Hz)	0.41	--	42.8	FS1	0.41	Normal operating conditions.
264 V (60 Hz)	0.41	--	42.8	FS1	0.41	Normal operating conditions.
Model: GT-43006-4024-5.0-T2						
90 V (50 Hz)	0.87	--	44.7	FS1	0.87	Normal operating conditions.
90 V (60 Hz)	0.89	--	44.7	FS1	0.89	Normal operating conditions.
100 V (50 Hz)	0.80	1	44.3	FS1	0.80	Normal operating conditions.
100 V (60 Hz)	0.80	1	44.4	FS1	0.80	Normal operating conditions.
240 V (50 Hz)	0.38	1	43.7	FS1	0.38	Normal operating conditions.
240 V (60 Hz)	0.39	1	43.7	FS1	0.39	Normal operating conditions.
264 V (50 Hz)	0.35	--	43.6	FS1	0.35	Normal operating conditions.
264 V (60 Hz)	0.36	--	43.7	FS1	0.36	Normal operating conditions.
Model: GT-43006-4024-T2						
90 V (50 Hz)	0.88	--	44.3	FS1	0.88	Normal operating conditions.
90 V (60 Hz)	0.89	--	44.4	FS1	0.89	Normal operating conditions.
100 V (50 Hz)	0.80	1	44.2	FS1	0.80	Normal operating conditions.
100 V (60 Hz)	0.81	1	44.2	FS1	0.81	Normal operating conditions.
240 V (50 Hz)	0.38	1	43.8	FS1	0.38	Normal operating conditions.
240 V (60 Hz)	0.39	1	43.9	FS1	0.39	Normal operating conditions.
264 V (50 Hz)	0.36	--	43.7	FS1	0.36	Normal operating conditions.
264 V (60 Hz)	0.36	--	44.4	FS1	0.36	Normal operating conditions.

IEC 60950-1						
Clause	Requirement + Test				Result - Remark	Verdict
U (V)	I (A)	Irated (A)	P (W)	Fuse #	Ifuse (A)	Condition/status
Model: GT-43006-4048-T2						
90 V (50 Hz)	0.85	--	43.9	FS1	0.85	Normal operating conditions.
90 V (60 Hz)	0.87	--	44.0	FS1	0.87	Normal operating conditions.
100 V (50 Hz)	0.78	1	43.6	FS1	0.78	Normal operating conditions.
100 V (60 Hz)	0.81	1	43.7	FS1	0.81	Normal operating conditions.
240 V (50 Hz)	0.44	1	42.9	FS1	0.44	Normal operating conditions.
240 V (60 Hz)	0.44	1	42.9	FS1	0.44	Normal operating conditions.
264 V (50 Hz)	0.41	--	42.8	FS1	0.41	Normal operating conditions.
264 V (60 Hz)	0.41	--	42.8	FS1	0.41	Normal operating conditions.
Supplementary information: --						

2.1.1.5 c) 1)	TABLE: max. V, A, VA test				P
Voltage (rated) (Vdc)	Current (rated) (A)	Voltage (max.) (V)	Current (max.) (A)	VA (max.) (VA)	
Model: GT-43006-4015-3.0-T3					
12	3.30	12.07	4.0	46.32	
Model: GT-43006-4015-T3					
15	2.70	15.10	3.1	45.54	
Model: GT-43006-4024-T3					
24	1.67	24.02	2.6	55.38	
Model: GT-43006-4048-T3					
48	0.83	48.01	1.2	56.40	
supplementary information: --					

2.2	TABLE: evaluation of voltage limiting components in SELV circuits			P
Component (measured between)	max. voltage (V) (normal operation)		Voltage Limiting Components	
	V peak	V d.c.		
Model: GT-43006-4015-3.0-T3				
T1 pin CT2 to pin to GND	49.6	--	--	
T1 pin CT2 after CS6 pin to GND	--	13.2	CS6	

IEC 60950-1			
Clause	Requirement + Test	Result - Remark	Verdict
T1 pin CT2 after D2 pin to GND	--	13.2	D2
Model: GT-43006-4015-T3			
T1 pin CT2 to pin to GND	47.2	--	--
T1 pin CT2 after CS6 pin to GND	--	27.2	CS6
T1 pin CT2 after D2 pin to GND	--	15.8	D2
Model: GT-43006-4024-T3			
T1 pin CT2 to pin to GND	64.0	--	--
T1 pin CT2 after CS6 pin to GND	59.0	--	CS6
T1 pin CT2 after RS19, PS20 pin to GND	--	24.8	RS19, PS20
T1 pin CT2 after D2 pin to GND	--	24.8	D2
Model: GT-43006-4048-T3			
T1 pin CT2 to pin to GND	132	--	--
T1 pin CT2 after CS6 pin to GND	112	--	CS6
T1 pin CT2 after RS19, PS20 pin to GND	--	49.6	RS19, PS20
T1 pin CT2 after D2 pin to GND	--	49.6	D2
Fault test performed on voltage limiting components	Voltage measured (V) in SELV circuits (V peak or V d.c.)		
Model: GT-43006-4015-3.0-T3			
D2 shorted	0Vdc		
Model: GT-43006-4015-T3			
D2 shorted	0Vdc		
Model: GT-43006-4024-T3			
D2 shorted	0Vdc		
Model: GT-43006-4048-T3			
D2 shorted	0Vdc		
supplementary information:			
Test voltage:264Vac, 60Hz			

IEC 60950-1			
Clause	Requirement + Test	Result - Remark	Verdict

2.5	TABLE: limited power sources		P
-----	-------------------------------------	--	---

Circuit output tested:				
Measured Uoc (V) with all load circuits disconnected:				
	Isc (A)		VA	
	Meas.	Limit	Meas.	Limit
Model: GT-43006-4015-3.0-T3, Output: Uoc=12.07Vdc				
Normal condition	4.0	8.0	46.32	100
Single fault: RS8 SC	3.5	8.0	41.02	100
Single fault: R9 SC	4.1	8.0	46.87	100
Model: GT-43006-4015-T3, Output: Uoc=15.10Vdc				
Normal condition	3.1	8.0	41.44	100
Single fault: RS8 SC	2.8	8.0	31.74	100
Single fault: R9 SC	3.1	8.0	47.04	100
Model: GT-43006-4024-T3, Output: Uoc=24.02				
Normal condition	2.6	8.0	55.38	100
Single fault: RS8 SC	2.2	8.0	47.63	100
Single fault: R9 SC	2.5	8.0	54.30	100
Model: GT-43006-4048-T3, Output: Uoc=48.01Vdc				
Normal condition	1.2	8.0	56.40	100
Single fault: RS8 SC	1.1	8.0	51.28	100
Single fault: R9 SC	1.2	8.0	57.93	100
supplementary information:				
SC=Short circuit, OC=Open circuit Input condition:264Vdc, 60Hz				

IEC 60950-1			
Clause	Requirement + Test	Result - Remark	Verdict

2.10.2	Table: working voltage measurement			P
Location	RMS voltage (V)	Peak voltage (V)	Comments	
For all models				
T1 pin1 to pin CT1	237	682	Max. Vp	
T1 pin2 to pin CT1	210	372	--	
T1 pin3 to pin CT1	213	420	--	
T1 pin4 to pin CT1	197	352	--	
T1 pin1 to pin CT2	252	648	--	
T1 pin2 to pin CT1	255	484	Max. Vrms	
T1 pin3 to pin CT2	183	388	--	
T1 pin4 to pin CT2	191	384	--	
CY1 primary pin to secondary pin	208	368	--	
U1 pin 3 to pin1	218	428	--	
U1 pin 3 to pin2	226	368	--	
U1 pin 4 to pin1	226	380	--	
U1 pin 4 to pin2	213	372	--	
supplementary information:				
circuitInput condition:240Vdc, 60Hz				

IEC 60950-1							
Clause	Requirement + Test	Result - Remark					Verdict
2.10.3 and 2.10.4	TABLE: Clearance and creepage distance measurements						P
Clearance (cl) and creepage distance (cr) at/of/between:	U peak (V)	U r.m.s. (V)	Required cl (mm)	cl (mm)	Required cr (mm)	cr (mm)	
All Class I models							
Functional:							
Two ends of the FS1	340	240	1.5	2.6	2.5	2.6	
Line and Neutral before current fuse	340	240	1.5	2.8	2.5	2.8	
Basic/supplementary:							
Pri. To GND	340	240	2.0	2.9	2.5	2.9	
Reinforced:							
Under U1 two terminals	428	240	4.2	5.6	5.0	5.6	
Under CY1 two terminals	368	240	4.0	5.6	5.0	5.6	
T1 Pri. To Sec. winding	682	255	4.8	7.2	5.2	7.2	
Pri. to User accessible	340	240	4.0	5.5	5.0	5.5	
All Class II models							
Functional:							
Two ends of the FS1	340	240	1.5	2.7	2.5	2.7	
Line and Neutral before current fuse	340	240	1.5	2.6	2.5	2.6	
Reinforced:							
Under U1 two terminals	428	240	4.2	5.6	5.0	5.6	
Under CY1 two terminals	368	240	4.0	5.6	5.0	5.6	
T1 Pri. To Sec. winding	682	255	4.8	7.2	5.2	7.2	
Pri. to User accessible	340	240	4.0	5.5	5.0	5.5	
Supplementary information:							

IEC 60950-1			
Clause	Requirement + Test	Result - Remark	Verdict

2.10.5	TABLE: Distance through insulation measurements					P
Distance through insulation (DTI) at/of:	U peak (V)	U rms (V)	Test voltage (Vac)	Required DTI (mm)	DTI (mm)	
RI: Optocoupler (U1)	428	240	3000	0.4	Min. 0.4	
RI: Enclosure	682	240	3000	0.4	Min. 1.5	
thin sheet material at/of:	U peak (V)	U rms (V)	Test voltage (Vac)	Required layer (s)	layer (s)	
RI: Insulating tape around the outer side of transformer T1	682	255	3000	Min.2	2	
Supplementary information: for both Class I and Class II equipments.						
1. FI: Functional insulation; BI: Basic insulation; SI: Supplementary insulation; RI: Reinforced insulation.						

IEC 60950-1			
Clause	Requirement + Test	Result - Remark	Verdict

4.5	TABLE: Thermal requirements						P
	Supply voltage (V)	90Vac/ 60Hz	264Vac /60Hz	90Vac/ 60Hz	264Vac /60Hz	--	—
	Ambient Tmin (°C)	40.0	40.0	40.0	40.0	--	—
	Ambient Tmax (°C)	40.0	40.0	40.0	40.0	--	—
Maximum measured temperature T of part/at::		T (°C)				Allowed Tmax (°C)	
		Model: GT-43006-4024-T3		Model: GT-43006-4048-T3		--	--
T1 coil		99.9	95.0	100.2	100.6	--	105*
T1 core		101.9	91.7	104.2	98.3	--	--
U1 body		91.8	82.8	89.9	90.3	--	100
CY1 body		88.1	73.3	86.7	83.4	--	125
CX1 body		63.8	55.0	61.9	59.9	--	100
MOV body		70.2	65.6	40.0	65.8	--	85
LF1 near PCB		85.2	73.2	82.6	75.6	--	130
LF2 near PCB		63.8	56.2	73.6	60.3	--	130
BD1 near PCB		99.8	80.5	100.3	97.8	--	130
Q1 near PCB		100.2	85.3	100.3	97.8	--	130
D2 near PCB		98.2	85.3	93.0	98.2	--	130
Inside of enclosure near T1		75.7	68.8	80.1	70.2	--	105
Outside of enclosure near T1		61.8	54.1	61.8	60.5	--	95
	Supply voltage (V)	90Vac/ 60Hz	264Vac /60Hz	--	--	--	—
	Ambient Tmin (°C)	40.0	40.0	--	--	--	—
	Ambient Tmax (°C)	40.0	40.0	--	--	--	—
Maximum measured temperature T of part/at::		T (°C)				Allowed Tmax (°C)	
		Model: GT-43006-4015-T3		--	--	--	--
T1 coil		98.2	95.3	--	--	--	105*

IEC 60950-1							
Clause	Requirement + Test			Result - Remark			Verdict
T1 core	95.8	92.7	--	--	--	--	--
U1 body	90.0	84.3	--	--	--	--	100
CY1 body	77.3	70.3	--	--	--	--	125
CX1 body	61.0	60.8	--	--	--	--	100
MOV body	68.7	66.6	--	--	--	--	85
LF1 near PCB	79.6	73.0	--	--	--	--	130
LF2 near PCB	70.1	57.6	--	--	--	--	130
BD1 near PCB	90.1	84.8	--	--	--	--	130
Q1 near PCB	87.2	78.8	--	--	--	--	130
D2 near PCB	92.1	85.8	--	--	--	--	130
Inside of enclosure near T1	75.7	67.8	--	--	--	--	105
Outside of enclosure near T1	61.1	49.7	--	--	--	--	95
Supplementary information:--							
Temperature T of winding:	t1 (°C)	R1 (Ω)	t2 (°C)	R2 (Ω)	T (°C)	Allowed Tmax (°C)	Insulation class
--	--	--	--	--	--	--	--
Supplementary information: The equipment was submitted and evaluated for maximum manufacturer's recommended ambient (Tmra) of 40°C. *: consid thermocouple minus 10K.							

4.7	TABLE: Resistance to fire					P
Part	Manufacturer of material	Type of material	Thickness (mm)	Flammability class	Evidence	
PCB	TECHNI TECHNOLOGY LTD	T2A, T2B, T4	Min. 1.6 mm	Min. V-0	UL E154355	
Alt.	CHEERFUL ELECTRONIC	03, 02, 03A	Min. 1.6 mm	Min. V-0	UL E199724	
Alt.	BRITE PLUS ELECTRONICS (SUZHOU) CO LTD	DKV0-3A, DGV0-3A	Min. 1.6 mm	Min. V-0	UL E177671	
Alt.	SHENZHEN TONGCHUANGXIN ELECTRONICS CO LTD	TCX	Min. 1.6 mm	Min. V-0	UL E250336	

IEC 60950-1					
Clause	Requirement + Test		Result - Remark		Verdict
Alt.	GUANGDONG HETONG TECHNOLOGY CO LTD	CEM1, 2V0, FR4	Min. 1.6 mm	Min. V-0	UL E243157
Alt.	DONGGUAN DAYSUN ELECTRONIC CO LTD	DS2	Min. 1.6 mm	Min. V-0	UL E251754
Alt.	SHANGHAI AREX PRECISION ELECTRONIC CO LTD	02V0 04V0	Min. 1.6 mm	Min. V-0	UL E186016
Alt.	KUOTIANG ENT LTD	C-2 C-2A	Min. 1.6 mm	Min. V-0	UL E227299
Alt.	PACIFIC WIN INDUSTRIAL LTD	PW-02 PW-03	Min. 1.6 mm	Min. V-0	UL E228070
Alt.	Interchangeable	Interchangeable	Min. 1.6 mm	Min. V-0	UL
Enclosure	SABIC INNOVATIVE PLASTICS B V	SE1X(GG)(F1)	Min. 1.5 mm	Min. V-1	UL E45329
Alt.	TEIJIN CHEMICALS LTD	LN-1250P, LN-1250G	Min. 1.5 mm	Min. V-0	UL E50075
Alt.	SABIC INNOVATIVE PLASTICS B V	940	Min. 1.5 mm	Min. V-1	UL E45329
Alt.	ABIC INNOVATIVE PLASTICS B V	915R	Min. 1.5 mm	Min. V-1	UL E45329
Alt.	Interchangeable	Interchangeable	Min. 1.5 mm	Min. V-1	UL
Supplementary information:--					

5.1	TABLE: touch current measurement			P
Measured between:	Measured (mA)	Limit (mA)	Comments/conditions	
Model: GT-43006-4048-T3				
L/N and earth	0.16	3.5	--	
Plastic enclosure with foil and Primiry	0.01	0.25	--	

IEC 60950-1			
Clause	Requirement + Test	Result - Remark	Verdict

Model: GT-43006-4048-T2			
L/N and secondary	0.18	0.25	--
Plastic enclosure with foil and Primiry	0.01	0.25	--
supplementary information:			
Note: Test voltage: 264 Vac, 60 Hz;			

5.2	TABLE: Electric strength tests, impulse tests and voltage surge tests			P
Test voltage applied between:	Voltage shape (AC, DC, impulse, surge)	Test voltage (V)	Breakdown Yes / No	
Model: GT-43006-4048-T3, GT-43006-4024-T3, GT-43006-4015-T3				
RI: L/N and secondary circuits(earth)	DC	4242	No	
RI: L/N and plastic enclosure covered with metal foil	DC	4242	No	
RI: Insulation tape around transformer per layer	AC	3000	No	
BI: Primary to earth	DC	4242	No	
Model: GT-43006-4048-T2, GT-43006-4024-T2 GT-43006-4015-T2				
RI: L/N and secondary circuits(earth)	DC	4242	No	
RI: L/N and plastic enclosure covered with metal foil	DC	4242	No	
Supplementary information:				
BI: Basic insulation; RI: Reinforced insulation.				

IEC 60950-1			
Clause	Requirement + Test	Result - Remark	Verdict

5.3	TABLE: Fault condition tests					P
	Ambient temperature (°C)				See below.	—
	Power source for EUT: Manufacturer, model/type, output rating				See appended table 1.5.1	—
Component No.	Fault	Supply voltage (V)	Test time	Fuse #	Fuse current (A)	Observation
Model: GT-43006-4015-3.0-T3						
T1 pin 2 to pin 3	S	264	10min	FS1	0.03	Unit shutdown. No hazards. No high temperature.
T1 pin1 to pin 4	S	264	10min	FS1	0.03	Unit shutdown. No hazards. No high temperature.
T1 pin CT1 to pin CT2	S	264	10min	FS1	0.03	Unit shutdown. No hazards. No high temperature.
T1 pin CT2 after D2 to GNG	S	264	1h	FS1	0.45	Overload to 0.68A unit shut down. No hazards. No high temperature.
Output	S	264	10min	FS1	0.03	Unit shutdown. No hazards.
Output	O/L	264	1h	FS1	0.45	Overload to 4.1A, unit shutdown. No hazards. No high temperature. Temp: T1 coil = 126.3 °C; U1=105 °C; Ambient = 28.9 °C
Model: GT-43006-4015-T3						
T1 pin 2 to pin 3	S	264	10min	FS1	0.03	Unit shutdown. No hazards. No high temperature.
T1 pin1 to pin 4	S	264	10min	FS1	0.03	Unit shutdown. No hazards. No high temperature.
T1 pin CT1 to pin CT2	S	264	10min	FS1	0.03	Unit shutdown. No hazards. No high temperature.
T1 pin CT2 after D2 to GNG	S	264	1h	FS1	0.46	Overload to 0.15A unit shut down. No hazards. No high temperature.
Output	S	264	10min	FS1	0.03	Unit shutdown. No hazards.
Output	O/L	264	1h	FS1	0.46	Overload to 3.3A, unit shutdown. No hazards. No high temperature. Temp: T1 coil = 120.6 °C; U1=109.3 °C; Ambient = 29.7 °C
Model: GT-43006-4024-T3						
T1 pin 2 to pin 3	S	264	10min	FS1	0.04	Unit shutdown. No hazards. No high temperature.
T1 pin1 to pin 4	S	264	10min	FS1	0.04	Unit shutdown. No hazards. No high temperature.

IEC 60950-1						
Clause	Requirement + Test				Result - Remark	Verdict
T1 pin CT1 to pin CT2	S	264	10min	FS1	0.04	Unit shutdown. No hazards. No high temperature.
T1 pin CT2 after D2 to GNG	S	264	1h	FS1	0.39	Overload to 0.3A unit shut down. No hazards. No high temperature.
Output	S	264	10min	FS1	0.04	Unit shutdown. No hazards.
Output	O/L	264	1h	FS1	0.39	Overload to 4.1A, unit shutdown. No hazards. No high temperature. Temp: T1 coil = 131.1°C; U1=103.3°C; Ambient = 27.6°C
Model: GT-43006-4048-T3						
T1 pin 2 to pin 3	S	264	10min	FS1	0.05	Unit shutdown. No hazards. No high temperature.
T1 pin1 to pin 4	S	264	10min	FS1	0.05	Unit shutdown. No hazards. No high temperature.
T1 pin CT1 to pin CT2	S	264	10min	FS1	0.05	Unit shutdown. No hazards. No high temperature.
T1 pin CT2 after D2 to GNG	S	264	1h	FS1	0.44	Overload to 0.3A unit shut down. No hazards. No high temperature.
Output	S	264	10min	FS1	0.05	Unit shutdown. No hazards.
Output	O/L	264	1h	FS1	0.44	Overload to 1.21A, unit shutdown. No hazards. No high temperature. Temp: T1 coil = 127.6°C; U1=92.7°C; Ambient = 29.9°C
Supplementary information: S: Short-circuited; O/L: Overloaded						

IEC 60950-1			
Clause	Requirement + Test	Result - Remark	Verdict

C.2	TABLE: transformers						P
Loc.	Tested insulation	Working voltage peak / V (2.10.2)	Working voltage rms / V (2.10.2)	Required electric strength (5.2)	Required clearance / mm (2.10.3)	Required creepage distance / mm (2.10.4)	Required distance thr. insul. (2.10.5)
T1	Primary/core to secondary(reinforced)	628	255	3000Vac	4.8	5.2	--
T1	Insulation tape	628	255	3000Vac	--	--	Min. 2 layers
Loc.	Tested insulation			Test voltage/ V	Measured clearance / mm	Measured creepage dist./ mm	Measured distance thr. insul. / mm; number of layers
T1	Primary/core to secondary(reinforced)			3000Vac	7.2	7.2	Triple wire used.
T1	Insulation tape			3000Vac	--	--	2 layers
supplementary information:							

IEC 60950-1

Clause	Requirement + Test	Result - Remark	Verdict
--------	--------------------	-----------------	---------

C.2	TABLE: transformers		P
------------	----------------------------	--	----------

Type XF00740

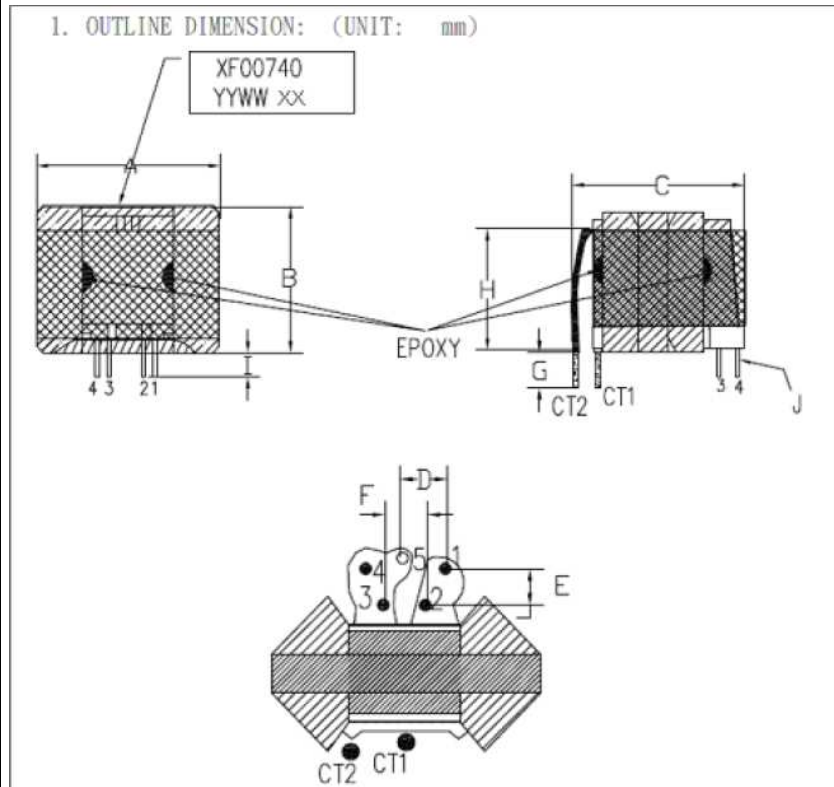

NOTE:
 1) XX Indicate the Factory ID;
 YY Provides production year;
 WW Provides production week.
 2) PIN5 CUT OFF.

DIM	A	B	C	D	E	F	G	H	I	J
	MAX	MAX	MAX	±0.3	±0.3	±0.3	±0.5	±2.0	±0.5	±0.1
SPEC	25	17.5	24	3	3	3.5	5	25	3.5	0.6
DESCRIPTION	TRANSFORMER		Customer P/N		XF00740		DATE		2011/5/25	

IEC 60950-1

Clause	Requirement + Test	Result - Remark	Verdict
--------	--------------------	-----------------	---------

2. SCHEMATIC:

Legend:
 TFL TUBE (透明)
 TFL TUBE (黑色)

3. WINDING SEQUENCE:

4. WINDING TABLE

Winding No (組別)	Margin Tape (擋牆膠帶)	PIN (腳位)	Wire&Wire Copper (線徑X股數)	Turns (圈數)	Winding Tape (繞線方式)	Tape Layer (膠帶層次)	Tube (套管)
N1	0	1-C	0.40ΦX1P	35Ts	密繞二層	1L	24*15/24*15
E1	0	~2	1mil*7mm	1.1Ts	背膠	2L	26*15/26*15
N2	0	CT2-CT1	0.65ΦX1P (三層絕緣線)	9Ts	疏繞	2L	20*15(透明)/20*15(黑色)
N3	0	3-2	0.20ΦX2P	16Ts	密繞中間	1L	26*15/26*15
N4	0	C~4	0.40ΦX1P	17Ts	密繞	2L	24*15/24*15
		C為中間抽頭, 待N4繞完後, 繞線鍍錫用擋牆包住, 反折回線包				2L	

IEC 60950_1F-ATTACHMENT			
Clause	Requirement + Test	Result - Remark	Verdict

ATTACHMENT TO TEST REPORT IEC 60950-1 EUROPEAN GROUP DIFFERENCES AND NATIONAL DIFFERENCES Information technology equipment – Safety – Part 1: General requirements			
Differences according to.....:		EN 60950-1:2006/A11:2009/A1:2010/A12:2011/A2:2013	
Attachment Form No.....:		EU_GD_IEC60950_1F	
Attachment Originator		SGS Fimko Ltd	
Master Attachment.....:		Date 2014-02	
Copyright © 2014 IEC System for Conformity Testing and Certification of Electrical Equipment (IECEE), Geneva, Switzerland. All rights reserved.			

EN 60950-1:2006/A11:2009/A1:2010/A12:2011/A2:2013 – CENELEC COMMON MODIFICATIONS

IEC 60950-1, GROUP DIFFERENCES (CENELEC common modifications EN)			
Clause	Requirement + Test	Result - Remark	Verdict
	Clauses, subclauses, notes, tables and figures which are additional to those in IEC60950-1 and it's amendmets are prefixed "Z"		—
Contents (A2:2013)	Add the following annexes: Annex ZA (normative) Normative references to international publications with their corresponding European publications Annex ZB (normative) Special national conditions Annex ZD (informative) IEC and CENELEC code designations for flexible cords		P
General	Delete all the "country" notes in the reference document (IEC 60950-1:2005) according to the following list: 1.4.8 Note 2 1.5.1 Note 2 & 3 1.5.7.1 Note 1.5.8 Note 2 1.5.9.4 Note 1.7.2.1 Note 4, 5 & 6 2.2.3 Note 2.2.4 Note 2.3.2 Note 2.3.2.1 Note 2 2.3.4 Note 2 2.6.3.3 Note 2 & 3 2.7.1 Note 2.10.3.2 Note 2 2.10.5.13 Note 3 3.2.1.1 Note 3.2.4 Note 3. 2.5.1 Note 2 4.3.6 Note 1 & 2 4.7 Note 4 4.7.2.2 Note 4.7.3.1 Note 2 5.1.7.1 Note 3 & 4 5.3.7 Note 1 6 Note 2 & 5 6.1.2.1 Note 2 6.1.2.2 Note 6.2.2 Note 6.2.2.1 Note 2 6.2.2.2 Note 7.1 Note 3 7.2 Note 7.3 Note 1 & 2 G.2.1 Note 2 Annex H Note 2		P
General (A1:2010)	Delete all the "country" notes in the reference document (IEC 60950-1:2005/A1:2010) according to the following list: 1.5.7.1 Note 6.1.2.1 Note 2 6.2.2.1 Note 2 EE.3 Note		P

IEC 60950_1F-ATTACHMENT			
Clause	Requirement + Test	Result - Remark	Verdict

IEC 60950-1, GROUP DIFFERENCES (CENELEC common modifications EN)			
Clause	Requirement + Test	Result - Remark	Verdict
General (A2:2013)	Delete all the "country" notes in the reference document (IEC 60950-1:2005/A2:2013) according to the following list: 2.7.1 Note * 2.10.3.1 Note 2 6.2.2. Note * Note of secretary: Text of Common Modification remains unchanged.		P
1.1.1 (A1:2010)	Replace the text of NOTE 3 by the following. NOTE 3 The requirements of EN 60065 may also be used to meet safety requirements for multimedia equipment. See IEC Guide 112, Guide on the safety of multimedia equipment. For television sets EN 60065 applies.		N/A
1.3.Z1	Add the following subclause: 1.3.Z1 Exposure to excessive sound pressure The apparatus shall be so designed and constructed as to present no danger when used for its intended purpose, either in normal operating conditions or under fault conditions, particularly providing protection against exposure to excessive sound pressures from headphones or earphones. NOTE Z1 A new method of measurement is described in EN 50332-1, Sound system equipment: Headphones and earphones associated with portable audio equipment - Maximum sound pressure level measurement methodology and limit considerations - Part 1: General method for "one package equipment", and in EN 50332-2, Sound system equipment: Headphones and earphones associated with portable audio equipment - Maximum sound pressure level measurement methodology and limit considerations - Part 2: Guidelines to associate sets with headphones coming from different manufacturers.		N/A
(A12:2011)	In EN 60950-1:2006/A12:2011 Delete the addition of 1.3.Z1 / EN 60950-1:2006 Delete the definition 1.2.3.Z1 / EN 60950-1:2006 /A1:2010		N/A
1.5.1 (Added info*)	Add the following NOTE: NOTE Z1 The use of certain substances in electrical and electronic equipment is restricted within the EU: see Directive 2002/95/EC. New Directive 2011/65/11 *		P
1.7.2.1 (A1:2010)	In addition, for a PORTABLE SOUND SYSTEM, the instructions shall include a warning that excessive sound pressure from earphones and headphones can cause hearing loss.		N/A

IEC 60950_1F-ATTACHMENT			
Clause	Requirement + Test	Result - Remark	Verdict

IEC 60950-1, GROUP DIFFERENCES (CENELEC common modifications EN)			
Clause	Requirement + Test	Result - Remark	Verdict
1.7.2.1 (A12.2011)	In EN 60950-1:2006/A12:2011 Delete NOTE Z1 and the addition for Portable Sound System. Add the following clause and annex to the existing standard and amendments.		N/A
	Zx Protection against excessive sound pressure from personal music players		N/A
	<p>Zx.1 General This sub-clause specifies requirements for protection against excessive sound pressure from personal music players that are closely coupled to the ear. It also specifies requirements for earphones and headphones intended for use with personal music players.</p> <p>A personal music player is a portable equipment for personal use, that:</p> <ul style="list-style-type: none"> – is designed to allow the user to listen to recorded or broadcast sound or video; and – primarily uses headphones or earphones that can be worn in or on or around the ears; and – allows the user to walk around while in use. <p>NOTE 1 Examples are hand-held or body-worn portable CD players, MP3 audio players, mobile phones with MP3 type features, PDA's or similar equipment.</p> <p>A personal music player and earphones or headphones intended to be used with personal music players shall comply with the requirements of this sub-clause.</p> <p>The requirements in this sub-clause are valid for music or video mode only.</p> <p>The requirements do not apply:</p> <ul style="list-style-type: none"> – while the personal music player is connected to an external amplifier; or – while the headphones or earphones are not used. <p>NOTE 2 An external amplifier is an amplifier which is not part of the personal music player or the listening device, but which is intended to play the music as a standalone music player.</p> <p>The requirements do not apply to:</p> <ul style="list-style-type: none"> – hearing aid equipment and professional equipment; <p>NOTE 3 Professional equipment is equipment sold through special sales channels. All products sold through normal electronics stores are considered not to be professional equipment.</p>		N/A

IEC 60950_1F-ATTACHMENT			
Clause	Requirement + Test	Result - Remark	Verdict

IEC 60950-1, GROUP DIFFERENCES (CENELEC common modifications EN)			
Clause	Requirement + Test	Result - Remark	Verdict
	<p>– analogue personal music players (personal music players without any kind of digital processing of the sound signal) that are brought to the market before the end of 2015.</p> <p>NOTE 4 This exemption has been allowed because this technology is falling out of use and it is expected that within a few years it will no longer exist. This exemption will not be extended to other technologies.</p> <p>For equipment which is clearly designed or intended for use by young children, the limits of EN 71-1 apply.</p>		N/A
	<p>Zx.2 Equipment requirements</p> <p>No safety provision is required for equipment that complies with the following:</p> <ul style="list-style-type: none"> – equipment provided as a package (personal music player with its listening device), where the acoustic output $L_{Aeq,T}$ is ≤ 85 dBA measured while playing the fixed “programme simulation noise” as described in EN 50332-1; and – a personal music player provided with an analogue electrical output socket for a listening device, where the electrical output is ≤ 27 mV measured as described in EN 50332-2, while playing the fixed “programme simulation noise” as described in EN 50332-1. <p>NOTE 1 Wherever the term acoustic output is used in this clause, the 30 s A-weighted equivalent sound pressure level $L_{Aeq,T}$ is meant. See also Zx.5 and Annex Zx.</p> <p>All other equipment shall:</p> <ol style="list-style-type: none"> a) protect the user from unintentional acoustic outputs exceeding those mentioned above; and b) have a standard acoustic output level not exceeding those mentioned above, and automatically return to an output level not exceeding those mentioned above when the power is switched off; and 		N/A

IEC 60950_1F-ATTACHMENT			
Clause	Requirement + Test	Result - Remark	Verdict

IEC 60950-1, GROUP DIFFERENCES (CENELEC common modifications EN)			
Clause	Requirement + Test	Result - Remark	Verdict
	<p>c) provide a means to actively inform the user of the increased sound pressure when the equipment is operated with an acoustic output exceeding those mentioned above. Any means used shall be acknowledged by the user before activating a mode of operation which allows for an acoustic output exceeding those mentioned above. The acknowledgement does not need to be repeated more than once every 20 h of cumulative listening time; and</p> <p>NOTE 2 Examples of means include visual or audible signals. Action from the user is always required.</p> <p>NOTE 3 The 20 h listening time is the accumulative listening time, independent how often and how long the personal music player has been switched off.</p> <p>d) have a warning as specified in Zx.3; and</p> <p>e) not exceed the following:</p> <ol style="list-style-type: none"> 1) equipment provided as a package (player with its listening device), the acoustic output shall be ≤ 100 dBA measured while playing the fixed "programme simulation noise" described in EN 50332-1; and 2) a personal music player provided with an analogue electrical output socket for a listening device, the electrical output shall be ≤ 150 mV measured as described in EN 50332-2, while playing the fixed "programme simulation noise" described in EN 50332-1. <p>For music where the average sound pressure (long term $L_{Aeq,T}$) measured over the duration of the song is lower than the average produced by the programme simulation noise, the warning does not need to be given as long as the average sound pressure of the song is below the basic limit of 85 dBA. In this case T becomes the duration of the song.</p> <p>NOTE 4 Classical music typically has an average sound pressure (long term $L_{Aeq,T}$) which is much lower than the average programme simulation noise. Therefore, if the player is capable to analyse the song and compare it with the programme simulation noise, the warning does not need to be given as long as the average sound pressure of the song is below the basic limit of 85 dBA.</p> <p>For example, if the player is set with the programme simulation noise to 85 dBA, but the average music level of the song is only 65 dBA, there is no need to give a warning or ask an acknowledgement as long as the average sound level of the song is not above the basic limit of 85 dBA.</p>		N/A

IEC 60950_1F-ATTACHMENT			
Clause	Requirement + Test	Result - Remark	Verdict

IEC 60950-1, GROUP DIFFERENCES (CENELEC common modifications EN)			
Clause	Requirement + Test	Result - Remark	Verdict
	<p>Zx.3 Warning The warning shall be placed on the equipment, or on the packaging, or in the instruction manual and shall consist of the following:</p> <ul style="list-style-type: none"> – the symbol of Figure 1 with a minimum height of 5 mm; and – the following wording, or similar: <p>“To prevent possible hearing damage, do not listen at high volume levels for long periods.”</p> <div style="text-align: center;">  </div> <p>Figure 1 – Warning label (IEC 60417-6044)</p> <p>Alternatively, the entire warning may be given through the equipment display during use, when the user is asked to acknowledge activation of the higher level.</p>		N/A
	<p>Zx.4 Requirements for listening devices (headphones and earphones)</p>		N/A
	<p>Zx.4.1 Wired listening devices with analogue input With 94 dBA sound pressure output $L_{Aeq,T}$, the input voltage of the fixed “programme simulation noise” described in EN 50332-2 shall be ≥ 75 mV.</p> <p>This requirement is applicable in any mode where the headphones can operate (active or passive), including any available setting (for example built-in volume level control).</p> <p>NOTE The values of 94 dBA – 75 mV correspond with 85dBA – 27 mV and 100 dBA – 150 mV.</p>		N/A

IEC 60950_1F-ATTACHMENT			
Clause	Requirement + Test	Result - Remark	Verdict

IEC 60950-1, GROUP DIFFERENCES (CENELEC common modifications EN)			
Clause	Requirement + Test	Result - Remark	Verdict
	<p>Zx.4.2 Wired listening devices with digital input With any playing device playing the fixed “programme simulation noise” described in EN 50332-1 (and respecting the digital interface standards, where a digital interface standard exists that specifies the equivalent acoustic level), the acoustic output $L_{Aeq,T}$ of the listening device shall be ≤ 100 dBA.</p> <p>This requirement is applicable in any mode where the headphones can operate, including any available setting (for example built-in volume level control, additional sound feature like equalization, etc.).</p> <p>NOTE An example of a wired listening device with digital input is a USB headphone.</p>		N/A
	<p>Zx.4.3 Wireless listening devices In wireless mode: – with any playing and transmitting device playing the fixed programme simulation noise described in EN 50332-1; and – respecting the wireless transmission standards, where an air interface standard exists that specifies the equivalent acoustic level; and – with volume and sound settings in the listening device (for example built-in volume level control, additional sound feature like equalization, etc.) set to the combination of positions that maximize the measured acoustic output for the abovementioned programme simulation noise, the acoustic output $L_{Aeq,T}$ of the listening device shall be ≤ 100 dBA.</p> <p>NOTE An example of a wireless listening device is a Bluetooth headphone.</p>		N/A
	<p>Zx.5 Measurement methods Measurements shall be made in accordance with EN 50332-1 or EN 50332-2 as applicable. Unless stated otherwise, the time interval T shall be 30 s.</p> <p>NOTE Test method for wireless equipment provided without listening device should be defined.</p>		N/A

IEC 60950_1F-ATTACHMENT			
Clause	Requirement + Test	Result - Remark	Verdict

IEC 60950-1, GROUP DIFFERENCES (CENELEC common modifications EN)			
Clause	Requirement + Test	Result - Remark	Verdict
2.7.1	<p>Replace the subclause as follows:</p> <p>Basic requirements</p> <p>To protect against excessive current, short-circuits and earth faults in PRIMARY CIRCUITS, protective devices shall be included either as integral parts of the equipment or as parts of the building installation, subject to the following, a), b) and c):</p> <p>a) except as detailed in b) and c), protective devices necessary to comply with the requirements of 5.3 shall be included as parts of the equipment;</p> <p>b) for components in series with the mains input to the equipment such as the supply cord, appliance coupler, r.f.i. filter and switch, short-circuit and earth fault protection may be provided by protective devices in the building installation;</p> <p>c) it is permitted for PLUGGABLE EQUIPMENT TYPE B or PERMANENTLY CONNECTED EQUIPMENT, to rely on dedicated overcurrent and short-circuit protection in the building installation, provided that the means of protection, e.g. fuses or circuit breakers, is fully specified in the installation instructions.</p> <p>If reliance is placed on protection in the building installation, the installation instructions shall so state, except that for PLUGGABLE EQUIPMENT TYPE A the building installation shall be regarded as providing protection in accordance with the rating of the wall socket outlet.</p>		P
2.7.2	This subclause has been declared 'void'.		N/A
3.2.3	Delete the NOTE in Table 3A, and delete also in this table the conduit sizes in parentheses.		N/A

IEC 60950_1F-ATTACHMENT			
Clause	Requirement + Test	Result - Remark	Verdict

IEC 60950-1, GROUP DIFFERENCES (CENELEC common modifications EN)									
Clause	Requirement + Test	Result - Remark	Verdict						
3.2.5.1	<p>Replace “60245 IEC 53” by “H05 RR-F”; “60227 IEC 52” by “H03 VV-F or H03 VVH2-F”; “60227 IEC 53” by “H05 VV-F or H05 VVH2-F2”.</p> <p>In Table 3B, replace the first four lines by the following:</p> <table border="0"> <tr> <td>Up to and including 6 </td> <td>0,75^{a)} </td> </tr> <tr> <td>Over 6 up to and including 10 </td> <td>(0,75)^{b)} 1,0 </td> </tr> <tr> <td>Over 10 up to and including 16 </td> <td>(1,0)^{c)} 1,5 </td> </tr> </table> <p>In the conditions applicable to Table 3B delete the words “in some countries” in condition^{a)}.</p> <p>In NOTE 1, applicable to Table 3B, delete the second sentence.</p>	Up to and including 6	0,75 ^{a)}	Over 6 up to and including 10	(0,75) ^{b)} 1,0	Over 10 up to and including 16	(1,0) ^{c)} 1,5		N/A
Up to and including 6	0,75 ^{a)}								
Over 6 up to and including 10	(0,75) ^{b)} 1,0								
Over 10 up to and including 16	(1,0) ^{c)} 1,5								
3.2.5.1 (A2:2013)	NOTE Z1 The harmonised code designations corresponding to the IEC cord types are given in Annex ZD		N/A						
3.3.4	<p>In Table 3D, delete the fourth line: conductor sizes for 10 to 13 A, and replace with the following:</p> <table border="0"> <tr> <td>Over 10 up to and including 16 </td> <td>1,5 to 2,5 </td> <td>1,5 to 4 </td> </tr> </table> <p>Delete the fifth line: conductor sizes for 13 to 16 A</p>	Over 10 up to and including 16	1,5 to 2,5	1,5 to 4		N/A			
Over 10 up to and including 16	1,5 to 2,5	1,5 to 4							
4.3.13.6 (A1:2010)	<p>Replace the existing NOTE by the following:</p> <p>NOTE Z1 Attention is drawn to:</p> <p>1999/519/EC: Council Recommendation on the limitation of exposure of the general public to electromagnetic fields 0 Hz to 300 GHz, and</p> <p>2006/25/EC: Directive on the minimum health and safety requirements regarding the exposure of workers to risks arising from physical agents (artificial optical radiation).</p>		N/A						
	Standards taking into account mentioned Recommendation and Directive which demonstrate compliance with the applicable EU Directive are indicated in the OJEC.		N/A						
Annex H	<p>Replace the last paragraph of this annex by:</p> <p>At any point 10 cm from the surface of the OPERATOR ACCESS AREA, the dose rate shall not exceed 1 µSv/h (0,1 mR/h) (see NOTE). Account is taken of the background level.</p> <p>Replace the notes as follows:</p> <p>NOTE These values appear in Directive 96/29/Euratom.</p> <p>Delete NOTE 2.</p>		N/A						

IEC 60950_1F-ATTACHMENT			
Clause	Requirement + Test	Result - Remark	Verdict

IEC 60950-1, GROUP DIFFERENCES (CENELEC common modifications EN)			
Clause	Requirement + Test	Result - Remark	Verdict
Bibliography	Additional EN standards.		—

ZA	NORMATIVE REFERENCES TO INTERNATIONAL PUBLICATIONS WITH THEIR CORRESPONDING EUROPEAN PUBLICATIONS		—
-----------	----------------------------------------------------------------------------------------------------------	--	---

ZB ANNEX (normative) SPECIAL NATIONAL CONDITIONS (EN)			
Clause	Requirement + Test	Result - Remark	Verdict
1.2.4.1	In Denmark , certain types of Class I appliances (see 3.2.1.1) may be provided with a plug not establishing earthing conditions when inserted into Danish socket-outlets.		N/A
1.2.13.14 (A11:2009)	In Norway and Sweden , for requirements see 1.7.2.1 and 7.3 of this annex.		N/A
1.5.7.1 (A11:2009)	In Finland, Norway and Sweden , resistors bridging BASIC INSULATION in CLASS I PLUGGABLE EQUIPMENT TYPE A must comply with the requirements in 1.5.7.1. In addition when a single resistor is used, the resistor must withstand the resistor test in 1.5.7.2.		N/A
1.5.8	In Norway , due to the IT power system used (see annex V, Figure V.7), capacitors are required to be rated for the applicable line-to-line voltage (230 V).	For Class I models only. Y-capacitor are all rated min.230V and complied with IEC 60384-14, and others component in such condition has suitable voltage rating. (see appended table 1.5.1)	P
1.5.9.4	In Finland, Norway and Sweden , the third dashed sentence is applicable only to equipment as defined in 6.1.2.2 of this annex.		N/A

IEC 60950_1F-ATTACHMENT			
Clause	Requirement + Test	Result - Remark	Verdict

ZB ANNEX (normative) SPECIAL NATIONAL CONDITIONS (EN)			
Clause	Requirement + Test	Result - Remark	Verdict
1.7.2.1	<p>In Finland, Norway and Sweden, CLASS I PLUGGABLE EQUIPMENT TYPE A intended for connection to other equipment or a network shall, if safety relies on connection to protective earth or if surge suppressors are connected between the network terminals and accessible parts, have a marking stating that the equipment must be connected to an earthed mains socket-outlet.</p> <p>The marking text in the applicable countries shall be as follows:</p> <p>In Finland: "Laite on liitettävä suojakoskettimilla varustettuun pistorasiaan"</p> <p>In Norway: "Apparatet må tilkoples jordet stikkontakt"</p> <p>In Sweden: "Apparaten skall anslutas till jordat uttag"</p>		N/A
1.7.2.1 (A11:2009)	<p>In Norway and Sweden, the screen of the cable distribution system is normally not earthed at the entrance of the building and there is normally no equipotential bonding system within the building. Therefore the protective earthing of the building installation need to be isolated from the screen of a cable distribution system.</p> <p>It is however accepted to provide the insulation external to the equipment by an adapter or an interconnection cable with galvanic isolator, which may be provided by e.g. a retailer.</p> <p>The user manual shall then have the following or similar information in Norwegian and Swedish language respectively, depending on in what country the equipment is intended to be used in:</p> <p>"Equipment connected to the protective earthing of the building installation through the mains connection or through other equipment with a connection to protective earthing – and to a cable distribution system using coaxial cable, may in some circumstances create a fire hazard. Connection to a cable distribution system has therefore to be provided through a device providing electrical isolation below a certain frequency range (galvanic isolator, see EN 60728-11)."</p>		

IEC 60950_1F-ATTACHMENT			
Clause	Requirement + Test	Result - Remark	Verdict

ZB ANNEX (normative) SPECIAL NATIONAL CONDITIONS (EN)			
Clause	Requirement + Test	Result - Remark	Verdict
	<p>NOTE In Norway, due to regulation for installations of cable distribution systems, and in Sweden, a galvanic isolator shall provide electrical insulation below 5 MHz. The insulation shall withstand a dielectric strength of 1,5 kV r.m.s., 50 Hz or 60 Hz, for 1 min.</p> <p>Translation to Norwegian (the Swedish text will also be accepted in Norway): "Utstyr som er koplet til beskyttelsesjord via nettplugg og/eller via annet jordtilkoplede utstyr – og er tilkoplede et kabel-TV nett, kan forårsake brannfare. For å unngå dette skal det ved tilkopling av utstyret til kabel-TV nettet installeres en galvanisk isolator mellom utstyret og kabel-TV nettet." Translation to Swedish: "Utrustning som är kopplad till skyddsjord via jordat vägguttag och/eller via annan utrustning och samtidigt är kopplad till kabel-TV nät kan i vissa fall medföra risk för brand. För att undvika detta skall vid anslutning av utrustningen till kabel-TV nät galvanisk isolator finnas mellan utrustningen och kabel-TV nätet."</p>		N/A
1.7.2.1 (A2:2013)	<p>In Denmark, CLASS I PLUGGABLE EQUIPMENT TYPE A intended for connection to other equipment or a network shall, if safety relies on connection to protective earth or if surge suppressors are connected between the network terminals and accessible parts, have a marking stating that the equipment must be connected to an earthed mains socket-outlet.</p> <p>The marking text in Denmark shall be as follows: In Denmark: "Apparatets stikprop skal tilsluttes en stikkontakt med jord, som giver forbindelse til stikproppens jord."</p>		N/A
1.7.5 1.7.5 (A11:2009)	<p>In Denmark, socket-outlets for providing power to other equipment shall be in accordance with the Heavy Current Regulations, Section 107-2-D1, Standard Sheet DK 1-3a, DK 1-5a or DK 1-7a, when used on Class I equipment. For STATIONARY EQUIPMENT the socket-outlet shall be in accordance with Standard Sheet DK 1-1b or DK 1-5a.</p> <p>For CLASS II EQUIPMENT the socket outlet shall be in accordance with Standard Sheet DKA 1-4a.</p>		N/A

IEC 60950_1F-ATTACHMENT			
Clause	Requirement + Test	Result - Remark	Verdict

ZB ANNEX (normative) SPECIAL NATIONAL CONDITIONS (EN)			
Clause	Requirement + Test	Result - Remark	Verdict
1.7.5 (A2:2013)	<p>In Denmark, socket-outlets for providing power to other equipment shall be in accordance with the DS 60884-2-D1:2011.</p> <p>For class I equipment the following Standard Sheets are applicable: DK 1-3a, DK 1-1c, DK 1-1d, DK 1-5a or DK 1-7a, with the exception for STATIONARY EQUIPMENT where the socket-outlets shall be in accordance with Standard Sheet DK 1-1b, DK 1-1c, DK 1-1d or DK 1-5a.</p> <p>Socket outlets intended for providing power to Class II apparatus with a rated current of 2,5 A shall be in accordance with DS 60884-2-D1 standard sheet DKA 1-4a. Other current rating socket outlets shall be in compliance with by DS 60884-2-D1 Standard Sheet DKA 1-3a or DKA 1-3b.</p> <p>Justification the Heavy Current Regulations, 6c</p>		N/A
2.2.4	In Norway , for requirements see 1.7.2.1, 6.1.2.1 and 6.1.2.2 of this annex.		N/A
2.3.2	In Finland, Norway and Sweden there are additional requirements for the insulation. See 6.1.2.1 and 6.1.2.2 of this annex.		N/A
2.3.4	In Norway , for requirements see 1.7.2.1, 6.1.2.1 and 6.1.2.2 of this annex.		N/A
2.6.3.3	In the United Kingdom , the current rating of the circuit shall be taken as 13 A, not 16 A.	For Class I models: complied check.	P
2.7.1	In the United Kingdom , to protect against excessive currents and short-circuits in the PRIMARY CIRCUIT of DIRECT PLUG-IN EQUIPMENT, tests according to 5.3 shall be conducted, using an external protective device rated 30 A or 32 A. If these tests fail, suitable protective devices shall be included as integral parts of the DIRECT PLUG-IN EQUIPMENT, so that the requirements of 5.3 are met.		N/A
2.10.5.13	In Finland, Norway and Sweden , there are additional requirements for the insulation, see 6.1.2.1 and 6.1.2.2 of this annex.		N/A

IEC 60950_1F-ATTACHMENT			
Clause	Requirement + Test	Result - Remark	Verdict

ZB ANNEX (normative) SPECIAL NATIONAL CONDITIONS (EN)			
Clause	Requirement + Test	Result - Remark	Verdict
3.2.1.1	<p>In Switzerland, supply cords of equipment having a RATED CURRENT not exceeding 10 A shall be provided with a plug complying with SEV 1011 or IEC 60884-1 and one of the following dimension sheets:</p> <p>SEV 6532-2.1991 Plug Type 15 3P+N+PE 250/400 V, 10 A</p> <p>SEV 6533-2.1991 Plug Type 11 L+N 250 V, 10 A</p> <p>SEV 6534-2.1991 Plug Type 12 L+N+PE 250 V, 10 A</p> <p>In general, EN 60309 applies for plugs for currents exceeding 10 A. However, a 16 A plug and socket-outlet system is being introduced in Switzerland, the plugs of which are according to the following dimension sheets, published in February 1998:</p> <p>SEV 5932-2.1998: Plug Type 25 , 3L+N+PE 230/400 V, 16 A</p> <p>SEV 5933-2.1998: Plug Type 21, L+N, 250 V, 16A</p> <p>SEV 5934-2.1998: Plug Type 23, L+N+PE .250 V, 16 A</p>		N/A
3.2.1.1	<p>In Denmark, supply cords of single-phase equipment having a rated current not exceeding 13 A shall be provided with a plug according to the Heavy Current Regulations, Section 107-2-D1.</p> <p>CLASS I EQUIPMENT provided with socket-outlets with earth contacts or which are intended to be used in locations where protection against indirect contact is required according to the wiring rules shall be provided with a plug in accordance with standard sheet DK 2-1a or DK 2-5a.</p> <p>If poly-phase equipment and single-phase equipment having a RATED CURRENT exceeding 13 A is provided with a supply cord with a plug, this plug shall be in accordance with the Heavy Current Regulations, Section 107-2-D1 or EN 60309-2.</p>		N/A

IEC 60950_1F-ATTACHMENT			
Clause	Requirement + Test	Result - Remark	Verdict

ZB ANNEX (normative) SPECIAL NATIONAL CONDITIONS (EN)			
Clause	Requirement + Test	Result - Remark	Verdict
3.2.1.1 (A2:2013)	<p>In Denmark, supply cords of single-phase equipment having a rated current not exceeding 13 A shall be provided with a plug according to DS 60884-2-D1.</p> <p>CLASS I EQUIPMENT provided with socket-outlets with earth contacts or which are intended to be used in locations where protection against indirect contact is required according to the wiring rules shall be provided with a plug in accordance with standard sheet DK 2-1a or DK 2-5a.</p> <p>If a single-phase equipment having a RATED CURRENT exceeding 13 A or if a poly-phase equipment is provided with a supply cord with a plug, this plug shall be in accordance with the standard sheets DK 6-1a in DS 60884-2-D1 or EN 60309-2.</p> <p>Justification the Heavy Current Regulations, 6c</p>		N/A
3.2.1.1	<p>In Spain, supply cords of single-phase equipment having a rated current not exceeding 10 A shall be provided with a plug according to UNE 20315:1994.</p> <p>Supply cords of single-phase equipment having a rated current not exceeding 2,5 A shall be provided with a plug according to UNE-EN 50075:1993.</p> <p>CLASS I EQUIPMENT provided with socket-outlets with earth contacts or which are intended to be used in locations where protection against indirect contact is required according to the wiring rules, shall be provided with a plug in accordance with standard UNE 20315:1994.</p> <p>If poly-phase equipment is provided with a supply cord with a plug, this plug shall be in accordance with UNE-EN 60309-2.</p>		N/A

IEC 60950_1F-ATTACHMENT			
Clause	Requirement + Test	Result - Remark	Verdict

ZB ANNEX (normative) SPECIAL NATIONAL CONDITIONS (EN)			
Clause	Requirement + Test	Result - Remark	Verdict
3.2.1.1	In the United Kingdom , apparatus which is fitted with a flexible cable or cord and is designed to be connected to a mains socket conforming to BS 1363 by means of that flexible cable or cord and plug, shall be fitted with a 'standard plug' in accordance with Statutory Instrument 1768:1994 - The Plugs and Sockets etc. (Safety) Regulations 1994, unless exempted by those regulations. NOTE 'Standard plug' is defined in SI 1768:1994 and essentially means an approved plug conforming to BS 1363 or an approved conversion plug.		N/A
3.2.1.1	In Ireland , apparatus which is fitted with a flexible cable or cord and is designed to be connected to a mains socket conforming to I.S. 411 by means of that flexible cable or cord and plug, shall be fitted with a 13 A plug in accordance with Statutory Instrument 525:1997 - National Standards Authority of Ireland (section 28) (13 A Plugs and Conversion Adaptors for Domestic Use) Regulations 1997.		N/A
3.2.4	In Switzerland , for requirements see 3.2.1.1 of this annex.	The appliance inlet complies with IEC 60320-1.	P
3.2.5.1	In the United Kingdom , a power supply cord with conductor of 1,25 mm ² is allowed for equipment with a rated current over 10 A and up to and including 13 A.		N/A
3.3.4	In the United Kingdom , the range of conductor sizes of flexible cords to be accepted by terminals for equipment with a RATED CURRENT of over 10 A up to and including 13 A is: • 1,25 mm ² to 1,5 mm ² nominal cross-sectional area.		N/A
4.3.6	In the United Kingdom , the torque test is performed using a socket outlet complying with BS 1363 part 1:1995, including Amendment 1:1997 and Amendment 2:2003 and the plug part of DIRECT PLUG-IN EQUIPMENT shall be assessed to BS 1363: Part 1, 12.1, 12.2, 12.3, 12.9, 12.11, 12.12, 12.13, 12.16 and 12.17, except that the test of 12.17 is performed at not less than 125 °C. Where the metal earth pin is replaced by an Insulated Shutter Opening Device (ISOD), the requirements of clauses 22.2 and 23 also apply.		N/A

IEC 60950_1F-ATTACHMENT			
Clause	Requirement + Test	Result - Remark	Verdict

ZB ANNEX (normative) SPECIAL NATIONAL CONDITIONS (EN)			
Clause	Requirement + Test	Result - Remark	Verdict
4.3.6	In Ireland , DIRECT PLUG-IN EQUIPMENT is known as plug similar devices. Such devices shall comply with Statutory Instrument 526:1997 - National Standards Authority of Ireland (Section 28) (Electrical plugs, plug similar devices and sockets for domestic use) Regulations, 1997.		N/A
5.1.7.1	In Finland, Norway and Sweden TOUCH CURRENT measurement results exceeding 3,5 mA r.m.s. are permitted only for the following equipment: <ul style="list-style-type: none"> • STATIONARY PLUGGABLE EQUIPMENT TYPE A that <ul style="list-style-type: none"> is intended to be used in a RESTRICTED ACCESS LOCATION where equipotential bonding has been applied, for example, in a telecommunication centre; and has provision for a permanently connected PROTECTIVE EARTHING CONDUCTOR; and is provided with instructions for the installation of that conductor by a SERVICE PERSON; • STATIONARY PLUGGABLE EQUIPMENT TYPE B; • STATIONARY PERMANENTLY CONNECTED EQUIPMENT. 		N/A

IEC 60950_1F-ATTACHMENT			
Clause	Requirement + Test	Result - Remark	Verdict

ZB ANNEX (normative) SPECIAL NATIONAL CONDITIONS (EN)			
Clause	Requirement + Test	Result - Remark	Verdict
6.1.2.1 (A1:2010)	<p>In Finland, Norway and Sweden, add the following text between the first and second paragraph of the compliance clause:</p> <p>If this insulation is solid, including insulation forming part of a component, it shall at least consist of either</p> <ul style="list-style-type: none"> - two layers of thin sheet material, each of which shall pass the electric strength test below, or - one layer having a distance through insulation of at least 0,4 mm, which shall pass the electric strength test below. <p>Alternatively for components, there is no distance through insulation requirements for the insulation consisting of an insulating compound completely filling the casing, so that CLEARANCES and CREEPAGE DISTANCES do not exist, if the component passes the electric strength test in accordance with the compliance clause below and in addition</p> <ul style="list-style-type: none"> - passes the tests and inspection criteria of 2.10.11 with an electric strength test of 1,5 kV multiplied by 1,6 (the electric strength test of 2.10.10 shall be performed using 1,5 kV), and - is subject to ROUTINE TESTING for electric strength during manufacturing, using a test voltage of 1,5 kV. 		N/A

IEC 60950_1F-ATTACHMENT			
Clause	Requirement + Test	Result - Remark	Verdict

ZB ANNEX (normative) SPECIAL NATIONAL CONDITIONS (EN)			
Clause	Requirement + Test	Result - Remark	Verdict
	<p>It is permitted to bridge this insulation with an optocoupler complying with 2.10.5.4 b).</p> <p>It is permitted to bridge this insulation with a capacitor complying with EN 60384-14:2005, subclass Y2.</p> <p>A capacitor classified Y3 according to EN 60384-14:2005, may bridge this insulation under the following conditions:</p> <ul style="list-style-type: none"> - the insulation requirements are satisfied by having a capacitor classified Y3 as defined by EN 60384-14, which in addition to the Y3 testing, is tested with an impulse test of 2,5 kV defined in EN 60950-1:2006, 6.2.2.1; - the additional testing shall be performed on all the test specimens as described in EN 60384-14: - the impulse test of 2,5 kV is to be performed before the endurance test in EN 60384-14, in the sequence of tests as described in EN 60384-14. 		N/A
6.1.2.2	In Finland, Norway and Sweden , the exclusions are applicable for PERMANENTLY CONNECTED EQUIPMENT, PLUGGABLE EQUIPMENT TYPE B and equipment intended to be used in a RESTRICTED ACCESS LOCATION where equipotential bonding has been applied, e.g. in a telecommunication centre, and which has provision for a permanently connected PROTECTIVE EARTHING CONDUCTOR and is provided with instructions for the installation of that conductor by a SERVICE PERSON.		N/A
7.2	In Finland, Norway and Sweden , for requirements see 6.1.2.1 and 6.1.2.2 of this annex. The term TELECOMMUNICATION NETWORK in 6.1.2 being replaced by the term CABLE DISTRIBUTION SYSTEM.		N/A
7.3 (A11:2009)	In Norway and Sweden , for requirements see 1.2.13.14 and 1.7.2.1 of this annex.		N/A

IEC 60950_1F-ATTACHMENT			
Clause	Requirement + Test	Result - Remark	Verdict

**Annex ZD
(informative)**

IEC and CENELEC code designations for flexible cords

Type of flexible cord	Code designations	
	IEC	CENELEC
PVC insulated cords		
Flat twin tinsel cord	60227 IEC 41	H03VH-Y
Light polyvinyl chloride sheathed flexible cord	60227 IEC 52	H03VV-F H03VVH2-F
Ordinary polyvinyl chloride sheathed flexible cord	60277 IEC 53	H05VV-F H05VVH2-F
Rubber insulated cords		
Braided cord	60245 IEC 51	H03RT-F
Ordinary tough rubber sheathed flexible cord	60245 IEC 53	H05RR-F
Ordinary polychloroprene sheathed flexible cord	60245 IEC 57	H05RN-F
Heavy polychloroprene sheathed flexible cord	60245 IEC 66	H07RN-F
Cords having high flexibility		
Rubber insulated and sheathed cord	60245 IEC 86	H03RR-H
Rubber insulated, crosslinked PVC sheathed cord	60245 IEC 87	H03RV4-H
Crosslinked PVC insulated and sheathed cord	60245 IEC 88	H03V4V4-H

IEC 60950_1F-ATTACHMENT

Clause	Requirement + Test	Result - Remark	Verdict
--------	--------------------	-----------------	---------

APPENDIX	National differences for Korea		—
	IEC 60950-1, 2 nd edition; Am 1:2009		
1.5.101	Plugs for the connection of the apparatus to the supply mains shall comply with the Korean requirement (KSC 8305).	To be evaluated when submitted for the national approval.	N/A
8	EMC The apparatus shall comply with the relevant CISPR standards.	To be evaluated when submitted for the national approval.	—

IEC 60950_1F-ATTACHMENT			
Clause	Requirement + Test	Result - Remark	Verdict

APPENDIX	National differences for Canada	IEC 60950-1, 2nd edition; Am 1:2009	
-----------------	----------------------------------------	-------------------------------------------------------	--

SPECIAL NATIONAL CONDITIONS
 The following is a summary of the key national differences based on national regulatory requirements, such as the Canadian Electrical Code (CEC) Part and the Canadian Building Code, which are referenced in legislation and which form the basis for the rules and practices followed in electrical and building installations

1.1.1	All equipment is to be designed to allow installation in accordance with the National Electrical Code (NEC), ANSI/NFPA 70, the Canadian Electrical Code (CEC), Part I, CAN/CSA C22.1, and when applicable, the National Electrical Safety Code, IEEE C2. Also, unless marked or otherwise identified, installation is allowed per the Standard for the Protection of Electronic Computer/Data-Processing Equipment, ANSI/NFPA 75.		P
1.4.14	For Pluggable Equipment Type A, the protection in the installation is assumed to be 20A.		P
1.5.5	For lengths exceeding 3.05 m, external interconnecting flexible cord and cable assemblies are required to be a suitable cable type (e.g., DP, CL2) specified in the CEC/NEC. For lengths 3.05 m or less, external interconnecting flexible cord and cable assemblies that are not types specified in the CEC are required to have special construction features and identification markings.		P
1.7.1	Equipment for use on a.c. mains supply systems with a neutral and more than one phase conductor (e.g. 120/240 V, 3-wire) require a special marking format for electrical ratings. A voltage rating that exceeds an attachment plug cap rating is only permitted if it does not exceed the extreme operating conditions in Table 2 of CAN/CSA C22.2 No. 235, and if it is part of a range that extends into the Table 2 "Normal Operating Conditions." Likewise, a voltage rating shall not be lower than the specified "Normal Operating Conditions," unless it is part of a range that extends into the "Normal Operating Conditions."		N/A

IEC 60950_1F-ATTACHMENT			
Clause	Requirement + Test	Result - Remark	Verdict
1.7.7	Wiring terminals intended to supply Class 2 outputs in accordance with CEC Part 1 or NEC shall be marked with the voltage rating and "Class 2" or equivalent. Marking shall be located adjacent to the terminals and shall be visible during wiring.		N/A
2.5	Where a fuse is used to provide Class 2, Limited Power Source, or TNV current limiting, it shall not be operator-accessible unless it is not interchangeable.		N/A
2.7.1	Suitable NEC/CEC branch circuit protection rated at the maximum circuit rating is required for all standard supply outlets and receptacles (such as supplied in power distribution units) if the supply branch circuit protection is not suitable. Power distribution transformers distributing power at 100 volts or more, and rated 10 kVA or more, require special transformer overcurrent protection.		N/A
3.2	Wiring methods (terminals, leads, etc.) used for the connection of the equipment to the mains shall be in accordance with the NEC/CEC.		N/A
3.2.1	Power supply cords are required to have attachment plugs rated not less than 125 percent of the rated current of the equipment.		N/A
3.2.1.2	Equipment connected to a centralized d.c. power system, and having one pole of the DC mains input terminal connected to the main protective earthing terminal in the equipment, is required to comply with special earthing, wiring, marking and installation instruction requirements.		N/A
3.2.3	Permanent connection of equipment to the mains supply by a power supply cord is not permitted, except for certain equipment, such as ATMs.		N/A
3.2.5	Power supply cords are required to be no longer than 4.5 m in length. Flexible power supply cords are required to be compatible with Tables 11 and 12 of the CEC and Article 400 of the NEC.		N/A
3.2.9	Permanently connected equipment is required to have a suitable wiring compartment and wire bending space.		N/A
3.3	Wiring terminals and associated spacings for field wiring connections shall comply with CSA C22.2 No. 0.		N/A
3.3.3	Wire binding screws are not permitted to attach conductors larger than 10 AWG (5.3 mm ²).		N/A

IEC 60950_1F-ATTACHMENT			
Clause	Requirement + Test	Result - Remark	Verdict
3.3.4	Terminals for permanent wiring, including protective earthing terminals, are required to be suitable for Canadian/US wire gauge sizes, rated 125 percent of the equipment rating, and be specially marked when specified (1.7.7).		N/A
3.4.2	Motor control devices are required for cord-connected equipment with a motor if the equipment is rated more than 12 A, or if the motor has a nominal voltage rating greater than 120 V, or is rated more than 1/3 hp (locked rotor current over 43 A).		N/A
3.4.8	Vertically-mounted disconnect switches and circuit breakers are required to have the "on" position indicated by the handle in the up position.		N/A
3.4.11	For computer room applications, equipment with battery systems capable of supplying 750 VA for five minutes are required to have a battery disconnect means that may be connected to the computer room remote power-off circuit.		N/A
4.3.12	The maximum quantity of flammable liquid stored in equipment is required to comply with NFPA 30.		N/A
4.3.13.5	Equipment with lasers is required to meet the Canadian Radiation Emitting Devices Act, REDR C1370 and/or Code of Federal Regulations 21 CFR 1040, as applicable.		N/A
4.7	For computer room applications, automated information storage systems with combustible media greater than 0.76 m ³ (27 cu ft) are required to have a provision for connection of either automatic sprinklers or a gaseous agent extinguishing system with an extended discharge.		N/A
4.7.3.1	For computer room applications, enclosures with combustible material measuring greater than 0.9 m ² (10 sq ft) or a single dimension greater than 1.8 m (6 ft) are required to have a flame spread rating of 50 or less. For other applications, enclosures with the same dimensions require a flame spread rating of 200 or less.		N/A
Annex H	Equipment that produces ionizing radiation is required to comply with the Canadian Radiation Emitting Devices Act, REDR C1370 and/or Code of Federal Regulations, 21 CFR 1020, as applicable.		N/A
	OTHER DIFFERENCES The following key national differences are based on requirements other than national regulatory requirements		—

IEC 60950_1F-ATTACHMENT			
Clause	Requirement + Test	Result - Remark	Verdict
1.5.1	Some components and materials associated with the risk of fire, electric shock, or personal injury are required to have component or material ratings in accordance with the applicable national (Canadian and/or U.S.) component or material standard requirements. These components include: attachment plugs, battery packs (rechargeable type, used with transportable equipment), cathode ray tubes, circuit breakers, communication circuit accessories, connectors (used for current interruption of non-LPS circuits), cord sets and power supply cords, direct plug-in equipment, enclosures (outdoor), flexible cords and cables, fuses (branch circuit), fuseholders, ground-fault current interrupters, industrial control equipment, insulating tape, interconnecting cables, lampholders, limit controls, printed wiring, protectors for communications circuits, receptacles, solid state controls, supplementary protectors, switches (including interlock switches), thermal cutoffs, thermostats, (multi-layer) transformer winding wire, transient voltage surge suppressors, tubing, wire connectors, and wire and cables.	Critical components are IEC/EN/UL certified. See list of critical components. There may be additional requirements for components in Canada.	P
1.6.1.2	A circuit for connection to the DC Mains Supply is classified as either a SELV Circuit, TNV-2 Circuit or Hazardous Voltage Circuit depending on the maximum operating voltage of the supply. This maximum operating voltage shall include consideration of the battery charging "float voltage" associated with the intended supply system, regardless of the marked power rating of the equipment.		N/A
2.3.1	For TNV-2 and TNV-3 circuits with other than ringing signals and with voltages exceeding 42.4 V _{peak} or 60 V _{d.c.} , the maximum acceptable current through a 2000 ohm resistor (or greater) connected across the voltage source with other loads disconnected is 7.1 mA peak or 30 mA d.c. under normal operating conditions.		N/A
2.3.2.1	In the event of a single fault between TNV and SELV circuits, the limits of 2.2.3 apply to SELV Circuits and accessible conductive parts.		N/A
2.6.3.3	The current rating of the circuit shall be taken as 20 A not 16 A		P
2.6.3.4	Protective bonding conductors of non-standard protective bonding constructions (e.g., printed circuit traces) may be subjected to the additional limited short circuit test conditions specified.		N/A

IEC 60950_1F-ATTACHMENT			
Clause	Requirement + Test	Result - Remark	Verdict
4.2.8.1	Enclosures around CRTs with a face diameter of 160 mm or more are required to reduce the risk of injury due to the implosion of the CRT.		N/A
4.3.2	Equipment with handles is required to comply with special loading tests.		N/A
5.1.8.3	Equipment intended to receive telecommunication ringing signals is required to comply with a special touch current measurement tests.		N/A
5.3.7	Internal (e.g., card cage) SELV circuit connectors and printed wiring board connectors that are accessible to the operator and that deliver power are to be overloaded. During abnormal operating testing, if a circuit is interrupted by the opening of a component, the test shall be repeated twice (three tests total) using new components as necessary.		P
6.4	Equipment intended for connection to telecommunication network outside plant cable is required to be protected against overvoltage from power line crosses in accordance with 6.4 and Annex NAC.		N/A
M.2	Continuous ringing signals up to 16 mA only are permitted if the equipment is subjected to special installation and performance restrictions.		N/A
Annex NAD	Equipment connected to a telecommunication and cable distribution networks and supplied with an earphone intended to be held against, or in the ear is required to comply with special acoustic pressure requirements.		N/A

IEC 60950_1F-ATTACHMENT			
Clause	Requirement + Test	Result - Remark	Verdict

ATTACHMENT TO TEST REPORT IEC 60950-1 with A1: 2009 and A2:2013 U.S.A. NATIONAL DIFFERENCES Information technology equipment – Safety – Part 1: General requirements	
Differences according to	UL 60950-1-07(Second Edition) + A1: 2011 + A2: 2014
Attachment Form No.....	US_ND_IEC60950_1F
Attachment Originator	UL
Master Attachment.....	Date 2014-07
Copyright © 2014 IEC System for Conformity Testing and Certification of Electrical Equipment (IECEE), Geneva, Switzerland. All rights reserved.	

SPECIAL NATIONAL CONDITIONS			
1.1.1	All equipment is designed as to allow installation in accordance with the National Electrical Code (NEC), ANSI/NFPA 70, Canadian Electrical Code (CEC), Part I, CAN/CSA C22.1, and if applicable, the National Electrical Safety Code, IEEE C2	Unit was evaluated according to IEC 60950-1. The requirements have to be checked during national approval.	P
	Also, unless marked or otherwise identified, installation is allowed per the Standard for the Protection of Electronic Computer/Data-Processing Equipment, ANSI/NFPA 75		P
1.1.2	Baby monitors are required to additionally comply with ASTM F2951, Consumer Safety Specification for Baby Monitors		N/A
1.4.14	For Pluggable Equipment Type A, the protection in the installation is assumed to be 20A.		P
1.5.5	For lengths exceeding 3.05 m, external interconnecting flexible cord and cable assemblies are required to be a suitable cable type (e.g., DP, CL2) specified in the NEC.		N/A
	For lengths 3.05 m or less, external interconnecting flexible cord and cable assemblies that are not types specified in the NEC are required to have special construction features and identification markings.		N/A
1.7.1	Equipment for use on a.c. mains supply systems with a neutral and more than one phase conductor (e.g. 120/240 V, 3-wire) require a special marking format for electrical ratings		N/A
	A voltage rating that exceeds an attachment plug cap rating is only permitted if it does not exceed the extreme operating conditions in Table 2 of CAN/CSA C22.2 No. 235, and		N/A
	- if it is part of a range that extends into the Table 2 "Normal Operating Conditions"		N/A

IEC 60950_1F-ATTACHMENT			
Clause	Requirement + Test	Result - Remark	Verdict
	Likewise, a voltage rating is not to be lower than the specified "Normal Operating Conditions," unless it is part of a range that extends into the "Normal Operating Conditions"		N/A
1.7.7	Wiring terminals intended to supply Class 2 outputs in accordance with NEC or CEC Part 1 or NEC are marked with the voltage rating and "Class 2" or equivalent		N/A
	- Marking is located adjacent to the terminals		N/A
	- Marking is visible during wiring		N/A
2.5	Where a fuse is used to provide Class 2, Limited Power Source, or TNV current limiting, it shall not be operator-accessible unless it is not interchangeable.		N/A
2.6.3.3	The first column on Table 2D modified to require, "Smaller of the RATED CURRENT of the equipment or the PROTECTIVE CURRENT RATING of the circuit under consideration."		N/A
2.7.1	Suitable NEC/CEC branch circuit protection rated at the maximum circuit rating is provided for all standard supply outlets and receptacles (such as supplied in power distribution units) if the supply branch circuit protection is not suitable.		N/A
	Power distribution transformers distributing power at 100 volts or more, and rated 10 kVA or more, provided with special transformer overcurrent protection		N/A
3.2	Wiring methods (terminals, leads, etc.) used for the connection of the equipment to the mains shall be in accordance with the NEC/CEC.		N/A
3.2.1	Power supply cords are required to have attachment plugs rated not less than 125 percent of the rated current of the equipment.		N/A
3.2.1.2	Equipment connected to a centralized d.c. power system, and having one pole of the DC mains input terminal connected to the main protective earthing terminal in the equipment, is required to comply with special earthing, wiring, marking and installation instruction requirements.		N/A
3.2.3	Permanent connection of equipment to the mains supply by a power supply cord is not permitted, except for certain equipment, such as ATMs.		N/A
3.2.5	Power supply cords are no longer than 4.5 m in length		N/A
	Minimum cord length is 1.5 m, with certain constructions such as external power supplies allowed to consider both input and output cord lengths into the requirement		N/A

IEC 60950_1F-ATTACHMENT			
Clause	Requirement + Test	Result - Remark	Verdict
	Flexible power supply cords are compatible with Article 400 of the NEC, and Tables 11 and 12 of the CEC		N/A
3.2.9	Permanently connected equipment is required to have a suitable wiring compartment and wire bending space.		N/A
3.3	Wiring terminals and associated spacings for field wiring connections shall comply with CSA C22.2 No. 0.		N/A
3.3.3	Wire binding screws are not permitted to attach conductors larger than 10 AWG (5.3 mm ²).		N/A
3.3.4	Terminals for permanent wiring, including protective earthing terminals, are suitable for Canadian/US wire gauge sizes, are		N/A
	- rated 125 per cent of the equipment rating, and		N/A
	- are specially marked when specified (1.7.7)		N/A
3.3.5	First column of Table 3E revised to require "Smaller of the RATED CURRENT of the equipment or the PROTECTIVE CURRENT RATING of the circuit under consideration."		N/A
3.4.2	Motor control devices are provided for cord-connected equipment with a motor if the equipment is rated more than 12 A,		N/A
	- or if the motor has a nominal voltage rating greater than 120 V		N/A
	- or is rated more than 1/3 hp (locked rotor current over 43 A)		N/A
3.4.8	Vertically-mounted disconnect switches and circuit breakers are required to have the "on" position indicated by the handle in the up position.		N/A
3.4.11	For computer room applications, equipment with battery systems capable of supplying 750 VA for five minutes are required to have a battery disconnect means that may be connected to the computer room remote power-off circuit.		N/A
4.3.12	The maximum quantity of flammable liquid stored in equipment is required to comply with NFPA 30.		N/A
4.3.13.5.1	Equipment with lasers is required to meet the U.S. Code of Federal Regulations 21 CFR 1040 (and the Canadian Radiation Emitting Devices Act, REDR C1370).		N/A
4.7	For computer room applications, automated information storage systems with combustible media greater than 0.76 m ³ (27 cu ft) are required to have a provision for connection of either automatic sprinklers or a gaseous agent extinguishing system with an extended discharge.		N/A



IEC 60950_1F-ATTACHMENT			
Clause	Requirement + Test	Result - Remark	Verdict
4.7.3.1	For computer room applications, enclosures with combustible material measuring greater than 0.9m ² (10 sq ft) or a single dimension greater than 1.8 m (6 ft) have a flame spread rating of 50 or less		N/A
	For other applications, enclosures with the same dimensions require a flame spread rating of 200 or less		N/A
4.7.3.1	Non-metallic enclosures of equipment for use in spaces used for environmental air (plenums) are required to comply with UL 2043		N/A
Annex H	Equipment that produces ionizing radiation is required to comply with the U.S. Code of Federal Regulations, 21 CFR 1020 (and the Canadian Radiation Emitting Devices Act, REDR C1370).		N/A
	OTHER DIFFERENCES		—
1.5.1	Some components and materials associated with the risk of fire, electric shock, or personal injury are required to have component or material ratings in accordance with the applicable national (U.S. and Canadian) component or material requirements. These components include: attachment plugs, battery packs (rechargeable type, used with transportable equipment), cathode ray tubes, circuit breakers, communication circuit accessories, connectors (used for current interruption of non-LPS circuits), cord sets and power supply cords, direct plug-in equipment, electrochemical capacitor modules (energy storage modules with ultracapacitors), enclosures (outdoor), flexible cords and cables, fuses (branch circuit), fuseholders, ground-fault current interrupters, industrial control equipment, insulating tape, interconnecting cables, lampholders, limit controls, printed wiring, protectors for communications circuits, receptacles, solid state controls, supplementary protectors, switches (including interlock switches), thermal cutoffs, thermostats, (multi-layer) transformer winding wire, surge protective devices, tubing, vehicle battery adapters, wire connectors, and wire and cables.		P
1.6.1.2	A circuit for connection to the DC Mains Supply is classified as a SELV Circuit, TNV-2 Circuit or Hazardous Voltage Circuit depending on the maximum operating voltage of the supply		N/A

IEC 60950_1F-ATTACHMENT			
Clause	Requirement + Test	Result - Remark	Verdict
	This maximum operating voltage includes consideration of the battery charging “float voltage” associated with the intended supply system, regardless of the marked power rating of the equipment		N/A
2.3.1	For TNV-2 and TNV-3 circuits with other than ringing signals and with voltages exceeding 42.4 V _{peak} or 60 V _{d.c.} , the maximum acceptable current through a 2000 ohm resistor (or greater) connected across the voltage source with other loads disconnected is 7.1 mA peak or 30 mA d.c. under normal operating conditions.	No TNV circuitry.	N/A
2.3.2.1	In the event of a single fault between TNV and SELV circuits, the limits of 2.2.3 apply to SELV Circuits and accessible conductive parts.	No TNV circuitry.	N/A
2.6.3.4	Protective bonding conductors of non-standard protective bonding constructions (e.g., printed circuit traces) may be subjected to the additional limited short circuit test conditions specified.		N/A
4.2.8.1	Enclosures around CRTs with a face diameter of 160 mm or more are required to reduce the risk of injury due to the implosion of the CRT.	No CRTs in the equipment.	N/A
4.3.2	Equipment with handles is required to comply with special loading tests.	The equipment has no handles.	N/A
5.1.8.3	Equipment intended to receive telecommunication ringing signals is required to comply with a special touch current measurement tests.	No TNV circuitry.	N/A
5.3.7	Internal (e.g., card cage) SELV circuit connectors and printed wiring board connectors that are accessible to the operator and that deliver power are overloaded	Not applicable.	N/A
	During abnormal operating testing, if a circuit is interrupted by the opening of a component, the test is repeated twice (three tests total) using new components as necessary		N/A
6.4	Equipment intended for connection to telecommunication network outside plant cable is required to be protected against overvoltage from power line crosses in accordance with 6.4 and Annex NAC.	No TNV circuitry.	N/A
Annex EE	UL articulated accessibility probe (Fig EE.3) required for assessing accessibility to document/media shredders instead of the Figure 2A test finger.		N/A
Annex M.2	Continuous ringing signals up to 16 mA only are permitted if the equipment is subjected to special installation and performance restrictions.	No ringing signals.	N/A

IEC 60950_1F-ATTACHMENT

Clause	Requirement + Test	Result - Remark	Verdict
Annex NAD	Equipment connected to a telecommunication and cable distribution networks and supplied with an earphone intended to be held against, or in the ear is required to comply with special acoustic pressure requirements.		N/A



IEC 60950_1F-ATTACHMENT			
Clause	Requirement + Test	Result - Remark	Verdict
APPENDIX	National differences for China	IEC 60950-1, 2nd edition	—
1.1.2	GB 4943.1-2011 applies to equipment for use at altitudes not exceeding 5000m above sea level, primarily in regions with moderate or tropical climates. Amend the third dashed paragraph of 1.1.2 as: —equipment intended to be used in vehicles, on board ships or aircraft, at altitudes greater than 5000m;	Only up to 2000m	N/A
1.4.5	After the third paragraph, add a paragraph: If the equipment is intended for direct connection to an AC mains supply, the tolerances on RATED VOLTAGE shall be taken as +10%,-10% unless a wider tolerance is declared by the manufacturer. The first dash paragraph "-the RATED VOLTAGE is 230V single -phase or 400V three-phase, in which case the tolerance shall be taken as +10% and -10%" of IEC 60950-1:2005 is deleted in GB 4943.1-2011	Tested with a supply tolerance $\pm 10\%$ which covered 220Vac for China, refer to main report.	P
1.4.12.1	Tma in clause 1.4.12.1 amended as: Tma: is the maximum ambient temperature permitted by the manufacturer's specification, or 35 °C, whichever is greater. Add note 1: For equipment not to be operated at tropical climatic conditions, Tma: is the maximum ambient temperature permitted by the manufacturer's specification, or 25 °C, whichever is greater. Add note 2: For equipment is to be operated at 2000m-5000m above sea leave, its temperature test conditions and temperature limits are under consideration.		P
1.5. 2	Add a note behind the first break off section in Clause 1.5.2: A component used shall comply with related requirements corresponding altitude of 5000m.		N/A
1.7	Add one paragraph before the last paragraph: The required marking and instruction should be given in normative Chinese unless otherwise specified.	The requirements have to be checked during national approval.	N/A

IEC 60950_1F-ATTACHMENT			
Clause	Requirement + Test	Result - Remark	Verdict
1.7.1	<p>Based on the AC mains supply of China, the RATED VOLTAGE should be 220V (single phase) or 380V (three-phases) for single rated voltage, for RATED VOLTAGE RANGE, it should cover 220V or 380V (three-phases), for multiple RATED VOLTAGES, one of them should be 220V or 380V (three-phases) and set on 220V or 380V (three-phases) when manufactured.</p> <p>And the RATED FREQUENCY or RATED FREQUENCY RANGE should be 50Hz or include 50Hz.</p>	Complied check.	P
1.7.2.1	<p>Add requirements of warning for equipment intended to be used at altitudes not exceeding 2000m or at non-tropical climate regions: For equipment intended to be used at altitude not exceeding 2000m, a warning label containing the following or a similar appropriate wording, or a symbol as in annex DD shall fixed to the equipment at readily visible place. "Only used at altitude not exceeding 2000m."</p> <div style="text-align: center;">  </div> <p>For equipment intended to be used in not-tropical climate regions, a warning label containing the following or a similar appropriate wording, or a symbol as in annex DD shall fixed to the equipment at readily visible place. "Only used in not-tropical climate regions."</p> <div style="text-align: center;">  </div> <p>If only the symbol used, the explanation of the symbol shall be contained in the instruction manual. The above statements shall be given in a language acceptable to the regions where the apparatus is intended to be used.</p>		P

IEC 60950_1F-ATTACHMENT			
Clause	Requirement + Test	Result - Remark	Verdict
2.7.1	<p>Amended the first paragraph as: Protection in PRIMARY CIRCUITS against overcurrent short-circuits and earth faults shall be provided as an integral part of the equipment except special provisions. And the protective device shall meet the requirement of Clause 5.3.</p> <p>Delete note of Clause 2.7.1.</p>	Complied check.	P
2.9.2	<p>First section of Clause 2.9.2 amended as two sections: Where required by 2.9.1, 2.10.8.3, 2.10.10 or 2.10.11, humidity conditioning is conducted for 120 h in a cabinet or room containing air with ambient temperature $40\pm 2^{\circ}\text{C}$ and a relative humidity of $(93\pm 3)\%$. During this conditioning the component or subassembly is not energized. For equipment not to be operated at tropical climatic conditions, Where required by 2.9.1, 2.10.8.3, 2.10.10 or 2.10.11, humidity conditioning is conducted for 48 h in a cabinet or room containing air with a relative humidity of $(93\pm 3)\%$. The temperature of the air, at all places where samples can be located, is maintained within 2°C of any convenient value between 20°C and 30°C such that condensation does not occur. Due to pretreatment of equipment operated at high altitude area is humidity conditioning withstand hot shock, specific requirements are to be considered.</p> <p>Add note: For equipment to be operated at 2000 m - 5000m above sea level, assessment and requirement of humidity conditioning for Insulation material properties are considered.</p>		P

IEC 60950_1F-ATTACHMENT			
Clause	Requirement + Test	Result - Remark	Verdict
2.10.3.1	Amend the third paragraph of Clause 2.10.3.1 to be: These requirements apply for equipment to be operated up to 2000 m above sea level. For equipment to be operated at more than 2000 m above sea level and up to 5000m above sea level, the minimum CLEARANCE shall be multiplied by the factor 1.48 corresponding altitude of 5000m given in Table A.2 of IEC 60664-1. For equipment to be operated at more than 5000 m above sea level, the minimum CLEARANCE shall be multiplied by the factor given in Table A.2 of IEC 60664-1. Linear interpolation is permitted between the nearest two points in Table A.2. The calculated minimum CLEARANCE using this multiplication factor shall be rounded up to the next higher 0,1 mm increment.	Only up to 2000m.	N/A
2.10.3.3& 2.10.3.4	Add "(applicable for altitude up to 2000m)" in header of Table 2K, 2L and 2M.	Added.	P
2.10.3.4	Add a new section above Table 2K and in Clause 2.10.3.4: Minimum CLEARANCES determined by above rules apply for equipment to be operated up to 2000m above sea level. For equipment to be operated at 2000 m - 5000m above sea level, the minimum CLEARANCE shall be multiplied by the factor 1.48 corresponding altitude of 5000m given in Table A.2 of GB/T16935.1 (IEC 60664-1) . For equipment to be operated at more than 5000 m above sea level, the minimum CLEARANCE shall be multiplied by the factor given in Table A.2 of GB/T16935.1.	Only up to 2000m.	N/A
3.2.1.1	Add a paragraph before the last paragraph: Plugs connected to AC mains supply shall comply with GB 1002 or GB 1003 or GB/T 11918 as applicable.		N/A
4.2.8	Clause 4.2.8 cathode ray tubes quoted Clause 18 of GB8898-2011. Delete note of Clause 4.2.8.		N/A

IEC 60950_1F-ATTACHMENT			
Clause	Requirement + Test	Result - Remark	Verdict
Annex E	Last section of Annex E amended as: For comparison of winding temperatures determined by the resistance method of this annex with the temperature limits of Table 4B, 35 °C shall be added to the calculated temperature rise. And add note: for equipment not to be operated at tropical climatic conditions, 25 °C shall be added to the calculated temperature rise to compare with the temperature of Table 4B.		N/A
Annex G.6	Change the second section of Clause G.6 to be: For equipment to be operated at 2000 m - 5000m above sea level, the minimum CLEARANCE shall be multiplied by the factor 1.48 corresponding altitude of 5000m given in Table A.2 of GB/T16935.1. For equipment to be operated at more than 5000 m above sea level, the minimum CLEARANCE shall be multiplied by the factor given in Table A.2 of IEC 60664-1. Linear interpolation is permitted between the nearest two points in Table A.2. The calculated minimum CLEARANCE using this multiplication factor shall be rounded up to the next higher 0,1 mm increment.		N/A
Annex BB (informative)	Amended as : The differences between Chinese national standards GB 4943.1-2011 and GB 4943-2001.		—

IEC 60950_1F-ATTACHMENT			
Clause	Requirement + Test	Result - Remark	Verdict
Annex DD (normative)	<p>Added annex DD: Instructions for the new safety warning labels.</p> <p>DD.1 Altitude warning label</p>  <p>Meaning of the label: Evaluation for apparatus only based on altitude not exceeding 2000m, therefor it's the only operating condition applied for the equipment .There may be some potential safety hazard if the equipment is used at altitude above 2000m .</p> <p>DD.2 Climate warning label</p>  <p>Meaning of the label: Evaluation for apparatus only based on temperate climate condition, therefor it's the only operating condition applied for the equipment .There may be some potential safety hazard if the equipment is used in tropical climate region.</p>	Only up to 2000m.	P
Annex EE (informative)	Added annex EE: Illustration relative to safety explanation in normative Chinese、Tibetan、Mongolian、Zhuang Language and Uighu.		N/A
Other amendments	In accordance with the relevant CTL decisions and the amendments of IEC 60950-1, the specific requirements or mistakes in IEC standard are corrected or editorially modified in this part, Including clause 1.7, 2.1.1.7, 2.9.2, Table 2H, Figure 2H, F.8, F.9, M.3 and Annex U.	Considered.	—

IEC 60950_1F-ATTACHMENT

Clause	Requirement + Test	Result - Remark	Verdict
Quoting standards and reference documents	<p>The principles of quoting and referring to other standards in Annex P and reference documents of IEC 60950-1 are as follows:</p> <p>If the date of the reference document is given, only that edition applies, excluding any subsequent corrigenda and amendments. However, parties to agreements based on this part are encouraged to investigate the possibility of applying the most recent editions of the reference documents. For undated references, the latest edition of the referenced document applies, including any corrigenda and amendments.</p> <p>For the usage of international standards in Chinese national standards and industry standards is various, in the aim of achieving easy operation and based on the requirements of GB/T 1.1 and GB/T 20000.2, when quoting an entire international standard in the normative quoting files and reference documents of Annex P of this part, the principles of quotation are as follows:</p> <ul style="list-style-type: none"> - If there is no national standard or industry standard corresponding to the international standard, then the international standard is quoted; - If there is national standard or industry standard corresponding to the international standard, then either the national or industry standard is quoted; - If the date of the national standard or industry standard is not given, the latest edition of the standard applies; - The national standard or industry standard number, corresponding international standard number and the consistency level code should be identified in parentheses behind the listed national standard or industry standard. <p>When quoting several chapters or clauses of the international standard, the principles of quotation are as follows:</p> <ul style="list-style-type: none"> - If there is no national standard or industry standard corresponding to the international standard, then the international standard is quoted; - If there is national standard or industry standard corresponding to the international standard, then either the national or industry standard is quoted. 		N/A

IEC 60950_1F-ATTACHMENT

Clause	Requirement + Test	Result - Remark	Verdict
	Meanwhile, in order to retain the relevant information on international standards, informative annex CC is increased, which gives the table about the comparison of the normative quoting files and reference documents in IEC 60950-1: 2005 and GB 4943.1-2011.		

IEC 60950_1F-ATTACHMENT			
Clause	Requirement + Test	Result - Remark	Verdict
APPENDIX	National differences for Australia and New Zealand		—
	IEC 60950-1, 2nd edition		—
	ANNEX ZZ (normative) Variations to IEC 60950-1, ED.2.0 (2005) for application in Australia and New Zealand		—
ZZ1	Introduction This Annex sets out variations and additional requirements to cover issues which have not been addressed by the International Standard. These variations indicate national variations for purposes of the IECEE CB Scheme and will be published in the IECEE CB Bulletin.		—
ZZ2	Variations The following variations apply to the source text:		—
1.2	Between the definitions for 'Person, service' and 'Range, rated frequency' <i>insert</i> the following: POTENTIAL IGNITION SOURCE 1.2.12		N/A
1.2.12.201	<i>Insert</i> a new Clause 1.2.12.201 after Clause 1.2.12.15 as follows: 1.2.12.201 POTENTIAL IGNITION SOURCE: Possible fault which can start a fire if the open-circuit voltage measured across an interruption or faulty contact exceeds a value of 50 V (peak) a.c. or d.c. and the product of the peak value of this voltage and the measured r.m.s current under normal operating conditions exceeds 15 VA. Such a faulty contact or interruption in an electrical connection includes those which may occur in CONDUCTIVE PATTERNS on PRINTED BOARDS . NOTE 201 An electronic protection circuit may be used to prevent such a fault from becoming a POTENTIAL IGNITION SOURCE . NOTE 202 This definition is from AS/NZS 60065:2003.		N/A

IEC 60950_1F-ATTACHMENT																				
Clause	Requirement + Test	Result - Remark	Verdict																	
1.5.1	<p>Add the following to the end of first paragraph: ‘or the relevant Australian/New Zealand Standard’.</p> <p>In NOTE 1, add the following after the word “standard: ‘or an Australian/New Zealand Standard’.</p>		P																	
1.5.2.	<p>Add the following to the end of first and third dash items: ‘or the relevant Australian/New Zealand Standard’.</p>		P																	
3.2.5.1	<p>Modify Table 3B as follows: Delete the first four rows and replace with the following:</p> <table border="1" data-bbox="422 945 1013 1279"> <thead> <tr> <th rowspan="2">RATED CURRENT of equipment A</th> <th colspan="2">Minimum conductor sizes</th> </tr> <tr> <th>Nominal cross-sectional area mm²</th> <th>AWG or kcmil [cross-sectional area in mm²] see Note 2</th> </tr> </thead> <tbody> <tr> <td>Over 0.2 up to and including 3</td> <td>0,5^{a)}</td> <td>18 [0,8]</td> </tr> <tr> <td>Over 3 up to and including 7.5</td> <td>0,75</td> <td>16 [1,3]</td> </tr> <tr> <td>Over 7.5 up to and including 10</td> <td>(0,75)^{b)} 1,00</td> <td>16 [1,3]</td> </tr> <tr> <td>Over 10 up to and including 16</td> <td>(1,0)^{c)} 1,5</td> <td>14 [2]</td> </tr> </tbody> </table> <p>Delete NOTE 1.</p> <p>Replace footnote ^{a)} with the following: ¹⁾ This nominal cross-sectional area is only allowed for Class II appliances if the length of the power supply cord, measured between the point where the cord, or cord guard, enters the appliance, and the entry to the plug does not exceed 2 m (0.5 mm² three-core supply flexible cords are not permitted; see AS/NZS 3191).</p>	RATED CURRENT of equipment A	Minimum conductor sizes		Nominal cross-sectional area mm ²	AWG or kcmil [cross-sectional area in mm ²] see Note 2	Over 0.2 up to and including 3	0,5 ^{a)}	18 [0,8]	Over 3 up to and including 7.5	0,75	16 [1,3]	Over 7.5 up to and including 10	(0,75) ^{b)} 1,00	16 [1,3]	Over 10 up to and including 16	(1,0) ^{c)} 1,5	14 [2]		N/A
RATED CURRENT of equipment A	Minimum conductor sizes																			
	Nominal cross-sectional area mm ²	AWG or kcmil [cross-sectional area in mm ²] see Note 2																		
Over 0.2 up to and including 3	0,5 ^{a)}	18 [0,8]																		
Over 3 up to and including 7.5	0,75	16 [1,3]																		
Over 7.5 up to and including 10	(0,75) ^{b)} 1,00	16 [1,3]																		
Over 10 up to and including 16	(1,0) ^{c)} 1,5	14 [2]																		
4.1.201	<p>Insert a new Clause 4.1.201 after Clause 4.1 as follows: 4.1.201 Display devices used for television purposes Display devices which may be used for television purposes, with a mass of 7 kg or more, shall comply with the requirements for stability and mechanical hazards, including the additional stability requirements for television receivers, specified in AS/NZS 60065.</p>		N/A																	

IEC 60950_1F-ATTACHMENT			
Clause	Requirement + Test	Result - Remark	Verdict
4.3.6	<i>Delete</i> the third paragraph and replace with the following: Equipment with a plug portion, suitable for insertion into a 10 A 3-pin flat-pin socket-outlet complying with AS/NZS 3112 shall comply with the requirements in AS/NZS 3112 for equipment with integral pins for insertion into socket-outlets.		N/A
4.3.13.5	<i>Add</i> the following to the end of the first paragraph: ' , or AS/NZS 2211.1'.		N/A
4.7	<i>Add</i> the following new paragraph to the end of the clause: 'For alternate tests refer to Clause 4.7.201.'		N/A

IEC 60950_1F-ATTACHMENT			
Clause	Requirement + Test	Result - Remark	Verdict
4.7.201	<p><i>Insert a new Clause 4.7.201 after Clause 4.7.3.6 as follows:</i></p> <p>4.7.201 Resistance to fire – Alternative tests</p> <p>4.7.201.1 General</p> <p>Parts of non-metallic material shall be resistant to ignition and spread of fire.</p> <p>This requirement does not apply to decorative trims, knobs and other parts unlikely to be ignited or to propagate flames from inside the apparatus, or the following:</p> <p>(a) Components that are contained in an enclosure having a flammability category of V-0 according to AS/NZS 60695.11.10 and having openings only for the connecting wires filling the openings completely, and for ventilation not exceeding 1 mm in width regardless of length.</p> <p>(b) The following parts which would contribute negligible fuel to a fire:</p> <ul style="list-style-type: none"> - small mechanical parts, the mass of which does not exceed 4 g, such as mounting parts, gears, cams, belts and bearings; - small electrical components, such as capacitors with a volume not exceeding 1,750 mm³, integrated circuits, transistors and optocoupler packages, if these components are mounted on material of flammability category V-1, or better, according to AS/NZS 60695.11.10. <p>NOTE In considering how to minimize propagation of fire and what 'small parts' are, account should be taken of the cumulative effect of small parts adjacent to each other for the possible effect of propagating fire from one part to another.</p> <p>Compliance shall be checked by the tests of 4.7.201.2, 4.7.201.3, 4.7.201.4 and 4.7.201.5.</p> <p>For the base material of printed boards, compliance shall be checked by the test of 4.7.201.5.</p> <p>The tests shall be carried out on parts of non-metallic material which have been removed from the apparatus. When the glow-wire test is carried out, the parts shall be placed in the same orientation as they would be in normal use.</p> <p>These tests are not carried out on internal wiring.</p>		N/A

IEC 60950_1F-ATTACHMENT

Clause	Requirement + Test	Result - Remark	Verdict
Cont.	<p>4.7.201.2 Testing of non-metallic materials Parts of non-metallic material shall be subject to the glow-wire test of AS/NZS 60695.2.11 which shall be carried out at 550°C. Parts for which the glow-wire test cannot be carried out, such as those made of soft or foamy material, shall meet the requirements specified in ISO 9772 for category FH-3 material. The glow-wire test shall be not carried out on parts of material classified at least FH-3 according to ISO 9772 provided that the sample tested was not thicker than the relevant part.</p> <p>4.7.201.3 Testing of insulating materials Parts of insulating material supporting POTENTIAL IGNITION SOURCES shall be subject to the glow-wire test of AS/NZS 60695.2.11 which shall be carried out at 750°C.</p> <p>The test shall be also carried out on other parts of insulating material which are within a distance of 3 mm of the connection.</p> <p>NOTE Contacts in components such as switch contacts are considered to be connections.</p> <p>For parts which withstand the glow-wire test but produce a flame, other parts above the connection within the envelope of a vertical cylinder having a diameter of 20 mm and a height of 50 mm shall be subjected to the needle-flame test. However, parts shielded by a barrier which meets the needle-flame test shall not be tested.</p> <p>The needle-flame test shall be made in accordance with AS/NZS 60695.11.5 with the following modifications:</p>		N/A

IEC 60950_1F-ATTACHMENT

Clause	Requirement + Test	Result - Remark	Verdict
--------	--------------------	-----------------	---------

<p>Cont.</p>	<p>Clause of AS/NZS 60695.11.5</p>	<p>Change</p>		<p>N/A</p>
	<p>9 Test procedure</p>			
	<p>9.2 Application of needle-flame</p>	<p><i>Replace</i> the first paragraph with: The specimen shall be arranged so that the flame can be applied to a vertical or horizontal edge as shown in the examples of figure 1. If possible the flame shall be applied at least 10 mm from a corner <i>Replace</i> the first paragraph with: The duration of application of the test flame shall be 30 s ±1 s.</p>		
	<p>9.3 Number of test specimens</p>	<p><i>Replace</i> with: The test shall be made on one specimen. If the specimen does not withstand the test, the test may be repeated on two further specimens, both of which shall withstand the test.</p>		
	<p>11 Evaluation of test results</p>	<p><i>Replace</i> with: The duration of burning (t_b) shall not exceed 30 s. However, for printed circuit boards, it shall not exceed 15 s.</p>		
<p>The needle-flame test shall not be carried out on parts of material classified as V-0 or V-1 according to AS/NZS 60695.11.10, provided that the sample tested was not thicker than the relevant part.</p> <p>4.7.201.4 Testing in the event of non-extinguishing material</p> <p>If parts, other than enclosures, do not withstand the glow wire tests of 4.7.201.3, by failure to extinguish within 30 s after the removal of the glow-wire tip, the needle-flame test detailed in 4.7.201.3 shall be made on all parts of non-metallic material which are within a distance of 50 mm or which are likely to be impinged upon by flame during the tests of 4.7.201.3. Parts shielded by a separate barrier which meets the needle-flame test need not be tested.</p>				

IEC 60950_1F-ATTACHMENT			
Clause	Requirement + Test	Result - Remark	Verdict

<p>Cont.</p>	<p>NOTE 1 - If the enclosure does not withstand the glow-wire test the equipment is considered to have failed to meet the requirements of Clause 4.7.201 without the need for consequential testing.</p> <p>NOTE 2 - If other parts do not withstand the glow-wire test due to ignition of the tissue paper and if this indicates that burning or glowing particles can fall onto an external surface underneath the equipment, the equipment is considered to have failed to meet the requirements of Clause 4.7.201 without the need for consequential testing.</p> <p>NOTE 3 - Parts likely to be impinged upon by the flame are considered to be those within the envelope of a vertical cylinder having a radius of 10 mm and a height equal to the height of the flame, positioned above the point of the material supporting, in contact with, or in close proximity to, connections.</p> <p>4.7.201.5 Testing of printed boards</p> <p>The base material of printed boards shall be subjected to the needle-flame test of Clause 4.7.201.3. The flame shall be applied to the edge of the board where the heat sink effect is lowest when the board is positioned as in normal use. The flame shall not be applied to an edge, consisting of broken perforations, unless the edge is less than 3 mm from a POTENTIAL IGNITION SOURCE.</p> <p>The test is not carried out if the —</p> <ul style="list-style-type: none"> - Printed board does not carry any POTENTIAL IGNITION SOURCE; - Base material of printed boards, on which the available apparent power at a connection exceeds 15 VA operating at a voltage exceeding 50 V and equal or less than 400 V (peak) a.c. or d.c. under normal operating conditions, is of flammability category V-1 or better according to AS/NZS 60695.11.10, or the printed boards are protected by an enclosure meeting the flammability category V-0 according to AS/NZS 60695.11.10, or made of metal, having openings only for connecting wires which fill the openings completely; or - Base material of printed boards, on which the available apparatus power at a connection exceeds 15 VA operating at a voltage exceeding 400 V (peak) a.c. or d.c. under normal operating conditions, and base material of printed boards supporting spark gaps which provides protection against overvoltages, is of flammability category V-0 according to AS/NZS 60695.11.10 or the printed boards are contained in a metal enclosure, having openings only for connecting wires which fill the openings completely. 		<p>N/A</p>
--------------	------------------------------------------------------------------------------------------------------------------------------------------------------------------------------------------------------------------------------------------------------------------------------------------------------------------------------------------------------------------------------------------------------------------------------------------------------------------------------------------------------------------------------------------------------------------------------------------------------------------------------------------------------------------------------------------------------------------------------------------------------------------------------------------------------------------------------------------------------------------------------------------------------------------------------------------------------------------------------------------------------------------------------------------------------------------------------------------------------------------------------------------------------------------------------------------------------------------------------------------------------------------------------------------------------------------------------------------------------------------------------------------------------------------------------------------------------------------------------------------------------------------------------------------------------------------------------------------------------------------------------------------------------------------------------------------------------------------------------------------------------------------------------------------------------------------------------------------------------------------------------------------------------------------------------------------------------------------------------------------------------------------------------------------------------------------------------------------------------------------------------------------------------------------------------------------------------------------------------------------------------------------------------------------------------------------------------------------------------------------------------------------------------------------------------------------------------------------------------------------------------------------------------------------------------------------------------------------------------------------------	--	------------

IEC 60950_1F-ATTACHMENT			
Clause	Requirement + Test	Result - Remark	Verdict
	<p>Compliance shall be determined using the smallest thickness of the material.</p> <p>NOTE – Available apparent power is the maximum apparent power which can be drawn from the supplying circuit through a resistive load whose value is chosen to maximise the apparent power for more than 2 min when the circuit supplied is disconnected.</p>		N/A
6.2.2	<p>For Australia only, <i>delete</i> the first paragraph and Note, and <i>replace</i> with the following:</p> <p>In Australia only, compliance with 6.2.2 shall be checked by the tests of both 6.2.2.1 and 6.2.2.2.</p>		N/A
6.2.2.1	<p>For Australia only, <i>delete</i> the first paragraph including the Notes, and <i>replace</i> with the following:</p> <p>In Australia only, the electrical separation is subjected to 10 impulses of alternating polarity, using the impulse test generator reference 1 of Table N.1. The interval between successive impulses is 60 s and the initial voltage, U_c, is:</p> <p>(i) for 6.2.1 a): 7.0 kV for hand-held telephones and for headsets and 2.5 kV for other equipment; and</p> <p>(ii) for 6.2.1 b) and 6.2.1 c): 1.5 kV.</p> <p>NOTE 201 – The 7 kV impulse simulates lightning surges on typical rural and semi-rural network lines.</p> <p>NOTE 202 – The value of 2.5 kV for 6.2.1 a) was chosen to ensure the adequacy of the insulation concerned and does not necessarily simulate likely overvoltages.</p>		N/A
6.2.2.2	<p>For Australia only, <i>delete</i> the second paragraph including the Note, and <i>replace</i> with the following.</p> <p>In Australia only, the a.c. test voltage is:</p> <p>(i) for 6.2.1 a): 3 kV; and</p> <p>(ii) for 6.2.1 b) and 6.2.1 c): 1.5 kV.</p> <p>NOTE 201 – Where there are capacitors across the insulation under test, it is recommended that d.c. test voltages are used.</p> <p>NOTE 202 – The 3 kV and 1.5 kV values have been determined considering the low frequency induced voltages from the power supply distribution system.</p>		N/A

IEC 60950_1F-ATTACHMENT			
Clause	Requirement + Test	Result - Remark	Verdict
7.3	<p><i>Add</i> the following before the first paragraph:</p> <p>Equipment providing functions that fall only within the scope of AS/NZS 60065 and that incorporate a PSTN interface, are not required to comply with this Clause where the only ports provided on the equipment, in addition to a coaxial cable connection and a PSTN interface, are audio or video ports and analogue or data ports not intended to be used for telecommunications purposes.</p>		N/A
Annex P	<p><i>Add</i> the following Normative References:</p> <p>AS/NZS 3191, Electric flexible cords</p> <p>AS/NZS 3112, Approval and test specification—Plugs and socket-outlets</p>		—
Index	<p><i>Insert</i> the following between ‘asbestos, not be used as insulation’ and ‘attitude see orientation’:</p> <p>AS/NZS 2211.1 4.3.13.5</p> <p>AS/NZS 3112 4.3.6</p> <p>AS/NZS 3191 3.2.5.1 (Table 3B)</p> <p>AS/NZS 60064 4.1.201</p> <p>AS/NZS 60695.2.11 4.7.201.2, 4.7.201.3</p> <p>AS/NZS 60695.11.10 4.7.201.1, 4.7.201.5</p> <p>AS/NZS 60695.11.5 4.7.201.3</p> <p><i>Insert</i> the following between ‘positive temperature coefficient (PTC) device’ and ‘powder’:</p> <p>potential ignition source 1.2.201, 4.7.201.3, 4.7.201.5</p>		—

IEC 60950_1F-ATTACHMENT

Clause	Requirement + Test	Result - Remark	Verdict
--------	--------------------	-----------------	---------

APPENDIX	National differences for Japan		—
		IEC 60950-1, 1st edition	
1.2.4.1	Add the following new notes. Note: Even if the equipment is designed as Class I, the equipment is regarded as Class 0I equipment when 2-pin adaptor with earthing lead wire or cord set having 2-pin plug with earthing lead wire is provided or recommended.	For Class I models: Power supply cord suitable for application and subject to country's national code and regulations to be provided by the manufacturer.	N/A
1.2.4.3A	Add the following new clause. 1.2.4.3A CLASS 0I EQUIPMENT Equipment having attachment plug without earthing blade, where protection against electric shock is achieved by: - using BASIC INSULATION, and - providing externally an earth terminal or a lead wire for earthing in order to connect those conductive parts that might assume a HAZARDOUS VOLTAGES in the event of BASIC INSULATION fault to the PROTECTIVE EARTHING CONDUCTOR in the building wiring. NOTE – Class 0I equipment may have a part constructed with Double Insulation or Reinforced Insulation. circuit.		N/A
1.3.2	Add the following notes after first paragraph: Note 1 Transportable or similar equipment that are relocated frequently for intended usage should not be designed as Class I or Class 0I equipment unless it is intended to be installed by service personnel. Note 2 Considering wiring circumstance in Japan, equipment intended to be installed where the provision for earthing connection is unlikely should not be designed as Class I or Class 0I equipment unless it is intended to be installed by service personnel.	Considered.	N/A

IEC 60950_1F-ATTACHMENT			
Clause	Requirement + Test	Result - Remark	Verdict
1.5.1	<p>Replace the first paragraph with the follows: Where safety is involved, components shall comply either with the requirements of this standard, with the safety aspects of the relevant JIS component standard, or IEC component standards in case there is no applicable JIS component standard is available. However, a component that falls within the scope of METI Ministerial ordinance No. 85 is properly used in accordance with its marked ratings, requirements of 1.5.4, 2.8.7 and 3.2.5 apply, and in addition, a cord connector of power supply cord set mating with appliance inlet complying with the standard sheet of IEC 60320-1, shall comply with relevant standard sheet of IEC 60320-1.</p> <p>Replace Note 1 with the following: Note 1 A JIS or an IEC component standard is considered relevant only if the component in question clearly falls within its scope.</p>	Critical components are IEC certified. See list of critical components. There may be additional requirements for components in Japan.	P
1.5.2	<p>Replace first sentence in the first dashed paragraph with the following:</p> <ul style="list-style-type: none"> - a component that has been demonstrated to comply with a JIS component standard harmonized with the relevant IEC component standard, or where such JIS component standard is not available, a component that has been demonstrated to comply with the relevant IEC component standard shall be checked for correct application and use in accordance with its rating. <p>Add a note after the first dashed paragraph as follows: Note 1 See 1.7.5A when Type C.14 appliance coupler rated 10 A per IEC 60320-1 is used with an equipment rated not more than 125 V and rated more than 10 A.</p> <p>Replace first sentence in the third dashed paragraph as follows:</p> <ul style="list-style-type: none"> - where no relevant IEC component standard or JIS component standard harmonized with the relevant IEC component standard exists, or where components are used in circuits not in accordance with their specified rating, the components shall be tested under the conditions occurring in the equipment. 	Critical components are IEC certified. See list of critical components. There may be additional requirements for components in Japan.	P
1.7.1	<p>Replace fifth dashed paragraph with the following:</p> <ul style="list-style-type: none"> - manufacturer's or responsible company's name or trade-mark or identification mark; 	The requirements have to be checked during national approval.	N/A

IEC 60950_1F-ATTACHMENT			
Clause	Requirement + Test	Result - Remark	Verdict
1.7.5A	<p>Add the following new clause. after 1.7.5</p> <p>1.7.5A Appliance Coupler</p> <p>If appliance coupler according to IEC60320-1, C.14(rated current: 10A)is used in equipment whose rated voltage is less than 125V and rated current is over 10A, the following instruction or equivalent shall be described in the user instruction.</p> <p>“ Use only designated cord set attached in this equipment”</p>		N/A
1.7.12	<p>Replace first sentence with the following:</p> <p>Instructions and equipment marking related to safety shall be in Japanese.</p>	To be evaluated when submitted for the national approval.	—
1.7.17A	<p>Add the following new clause. after 1.7.17</p> <p>1.7.17A Marking for CLASS 0I EQUIPMENT</p> <p>For CLASS 0I EQUIPMENT, the following instruction shall be marked on the visible place of the mains plug or the main body:</p> <p>“ Provide an earthing connection”</p> <p>Moreover, for CLASS 0I EQUIPMENT, the following or equivalent instruction shall be indicated on the visible place of the main body or written in the operating instructions:</p> <p>“ Provide an earthing connection before the mains plug is connected to the mains. And, when disconnecting the earthing connection, be sure to disconnect after pulling out the mains plug from the mains.”</p>	Not applicable.	N/A
2.6.3.2	<p>Add the following after 1st paragraph.</p> <p>This also applies to the conductor of lead wire for protective earthing of CLASS 0I EQUIPMENT.</p>	Not applicable.	N/A
2.6.4.2	<p>Replace 1st paragraph with the following.</p> <p>Equipment required to have protective earthing shall have a main protective earthing terminal.</p> <p>For equipment with a DETACHABLE POWER SUPPLY CORD, the earthing terminal in the appliance inlet is regarded as the main protective earthing terminal except for CLASS 0I EQUIPMENT providing separate main protective earthing terminal other than appliance inlet.</p>	For Class I models: Complied check.	P
2.6.5.4	<p>Replace 1st sentence with the following.</p> <p>Protective earthing connections of CLASS I EQUIPMENT shall make earlier and break later than the supply connections in each of the following:</p>	For Class I models: An appliance coupler used.	P

IEC 60950_1F-ATTACHMENT			
Clause	Requirement + Test	Result - Remark	Verdict
2.6.5.8A	Add the following new clause. after 2.6.5.8A 2.6.5.8A Earthing of CLASS 0I EQUIPMENT Plugs with a lead wire for earthing shall not be used for equipment having a rated voltage exceeding 150V. For plugs with a lead wire for earthing, the lead wire shall not be earthed by a clip. CLASS 0I EQUIPMENT shall be provided with an earthing terminal or lead wire for earthing in the external location where easily visible.	Class I equipment.	N/A
3.2.3	Add the following after Table 3A: Table 3A applies when cables complying JIS C 3662 or JIS C 3663 are used. In case of other cables, cable entries shall be so designed that a conduit suitable for the cable used can be fitted.	Considered.	N/A
3.2.5.1	Add the following to the last of first dashed paragraph. Or mains cords shall be of the sheathed type complying with Appendix 1 of Article 1 of the Ministerial Ordinance on stipulating technical requirements for the Electrical Appliance.. Add the following to the last of second dashed paragraph. Or mains cords shall be of the sheathed type complying with Appendix 1 of Article 1 of the Ministerial Ordinance on stipulating technical requirements for the Electrical Appliance.. Delete 1) in Table 3B.	Considered.	N/A
3.3.4	Add the following note to Table 3D: Note For cables other than those complying with JIS C 3662 or JIS C 3663, terminals shall be suitable for the size of the intended cables.	Considered.	N/A
3.3.7	Add the following after the first sentence: This requirement is not applicable to the external earthing terminal of Class 0I equipment.	Considered.	N/A
4.3.4	Add the following after the first sentence: This requirement also applies to those connections in Class 0I equipment, where CLEARANCE or CREEPAGE DISTANCES over BASIC INSULATION would be reduced to less than the values specified in 2.10.	Considered.	N/A
5.1.3	Add a note after the first paragraph as follows: Note – Attention should be drawn to that majority of three-phase power system in Japan is of delta connection, and therefore, in that case, test is conducted using the test circuit from IEC 60990, figure 13.		N/A

IEC 60950_1F-ATTACHMENT

Clause	Requirement + Test	Result - Remark	Verdict																						
5.1.6	<p>Replace Table 5A. as follows</p> <table border="1" data-bbox="422 421 991 1131"> <thead> <tr> <th>Type of equipment</th> <th>Terminal A of measuring instrument connected to:</th> <th>Maximum TOUCH CURRENT mA r.m.s. 1)</th> <th>Maximum PROTECTIVE CONDUCTOR CURRENT</th> </tr> </thead> <tbody> <tr> <td>ALL equipment</td> <td>ALL equipment Accessible parts and circuits not connected to protective earth</td> <td>0,25</td> <td>-</td> </tr> <tr> <td>HAND-HELD MOVABLE (other than HAND-HELD, but including TRANSPORTABLE EQUIPMENT)</td> <td rowspan="3">Equipment main protective earthing terminal (if any) CLASS I EQUIPMENT</td> <td>0,75</td> <td>-</td> </tr> <tr> <td>STATIONARY, PLUGGABLE TYPE A</td> <td>3,5</td> <td>-</td> </tr> <tr> <td>ALL other STATIONARY EQUIPMENT - not subject to the conditions of 5.1.7 - subject to the conditions of 5.1.7</td> <td>3,5</td> <td>-</td> </tr> <tr> <td>HAND-HELD Others</td> <td>Equipment main protective earthing terminal (if any) CLASS 0I EQUIPMENT</td> <td>0,5 1,0</td> <td>- -</td> </tr> </tbody> </table> <p>1) If peak values of TOUCH-CURRENT are measured, the maximum values obtained by multiplying the r.m.s. values by 1,414.</p>	Type of equipment	Terminal A of measuring instrument connected to:	Maximum TOUCH CURRENT mA r.m.s. 1)	Maximum PROTECTIVE CONDUCTOR CURRENT	ALL equipment	ALL equipment Accessible parts and circuits not connected to protective earth	0,25	-	HAND-HELD MOVABLE (other than HAND-HELD, but including TRANSPORTABLE EQUIPMENT)	Equipment main protective earthing terminal (if any) CLASS I EQUIPMENT	0,75	-	STATIONARY, PLUGGABLE TYPE A	3,5	-	ALL other STATIONARY EQUIPMENT - not subject to the conditions of 5.1.7 - subject to the conditions of 5.1.7	3,5	-	HAND-HELD Others	Equipment main protective earthing terminal (if any) CLASS 0I EQUIPMENT	0,5 1,0	- -		P
Type of equipment	Terminal A of measuring instrument connected to:	Maximum TOUCH CURRENT mA r.m.s. 1)	Maximum PROTECTIVE CONDUCTOR CURRENT																						
ALL equipment	ALL equipment Accessible parts and circuits not connected to protective earth	0,25	-																						
HAND-HELD MOVABLE (other than HAND-HELD, but including TRANSPORTABLE EQUIPMENT)	Equipment main protective earthing terminal (if any) CLASS I EQUIPMENT	0,75	-																						
STATIONARY, PLUGGABLE TYPE A		3,5	-																						
ALL other STATIONARY EQUIPMENT - not subject to the conditions of 5.1.7 - subject to the conditions of 5.1.7		3,5	-																						
HAND-HELD Others	Equipment main protective earthing terminal (if any) CLASS 0I EQUIPMENT	0,5 1,0	- -																						
7.2	<p>Add the following after the paragraph: However, the separation requirements and tests of 6.2.1 a), b) and c) do not apply to a CABLE DISTRIBUTION SYSTEM if all of the following apply:</p> <ul style="list-style-type: none"> - the circuit under consideration is a TNV-1 CIRCUIT; and - the common or earthed side of the circuit is connected to the screen of the coaxial cable and to all accessible parts and circuits (SELV, accessible metal parts and LIMITED CURRENT CIRCUITS, if any); and - the screen of the coaxial cable is intended to be connected to earth in the building installation. 		N/A																						
W.1	<p>Replace second and third sentence in the first paragraph with the following: This distinction between earthed and unearthed (floating) circuit is not the same as between CLASS I EQUIPMENT, CLASS 0I EQUIPMENT and CLASS II EQUIPMENT. Floating circuits can exist in CLASS I EQUIPMENT or CLASS 0I EQUIPMENT and earthed circuits in CLASS II EQUIPMENT.</p>		N/A																						

IEC 60950_1F-ATTACHMENT			
Clause	Requirement + Test	Result - Remark	Verdict
Annex JA	<p>Add a new annex JA with the following contents.</p> <p style="text-align: center;">Annex JA (normative) Document shredding machines</p> <p>Document shredding machines shall also comply with the requirements of this annex except those of STATIONARY EQUIPMENT used by connecting directly to an AC MAINS SUPPLY of three-phase 200V or more.</p> <p>JA.1 Markings and instructions The symbol  (JIS S 0101:2000, 6.2.4) and the following precautions for use shall be marked on readily visible part adjacent to document feed opening. The marking shall be clearly legible, permanent, and easily discernible; - that use by an infants/children may cause a hazard of injury etc.;; - that a hand can be drawn into the mechanical section for shredding when touching the document-slot; - that clothing can be drawn into the mechanical section for shredding when touching the document-slot; - that hairs can be drawn into the mechanical section for shredding when touching the document-slot; - in case of equipment incorporating a commutator motor, that equipment may catch fire or explode by spraying of flammable gas.</p> <p>JA.2 Inadvertent reactivation Any safety interlock that can be operated by means of the test finger, Figure JA.1, is considered to be likely to cause inadvertent reactivation of the hazard.</p> <p>Compliance is checked by inspection and, where necessary, by a test with the test finger, Figure JA.1</p>		N/A

IEC 60950_1F-ATTACHMENT

Clause	Requirement + Test	Result - Remark	Verdict
--------	--------------------	-----------------	---------

	<p>JA.3 Disconnection from the mains supply Document shredding machines shall incorporate an isolating switch complying with sub-clause 3.4.2 as the device disconnecting the power of hazardous moving parts. For this switch, two-position (single-use) switch or multi-position (multifunction) switch (e.g., slide switch) may be used. If two-position switch, the positions for "ON" and "OFF" shall be indicated in accordance with sub-clause 1.7.8. If multi-position switch, the position for "OFF" shall be indicated in accordance with sub-clause 1.7.8 and other positions shall be indicated with proper terms or symbols.</p> <p>Compliance is checked by inspection</p> <p>JA.4 Protection against hazardous moving parts Any warning shall not be used instead of the structure for preventing access to hazardous moving parts. Document shredding machines shall comply with the following requirements.</p> <p>Insert the test finger, Figure JA.1, into all openings in MECHANICAL ENCLOSURES without applying appreciable force. It shall not be possible to touch hazardous moving parts with the test finger. This consideration applies to all sides of MECHANICAL ENCLOSURES when the equipment is mounted as intended . Before testing with the test finger, remove the parts detachable without a tool.</p> <p>Insert the wedge-probe, Figure JA.2, into the document-slot. And, against all directions of openings, if straight-cutting type, a force of 45 N shall apply to the probe, and 90 N if cross-cutting type. In this case, the weight of the probe is to be factored into the overall applied force. Before testing with the wedge-probe, remove the parts detachable without a tool. It shall not be possible to touch any hazardous moving parts, including the shredding roller or the mechanical section for shedding, with the probe.</p>		N/A
--	-------------------------------------------------------------------------------------------------------------------------------------------------------------------------------------------------------------------------------------------------------------------------------------------------------------------------------------------------------------------------------------------------------------------------------------------------------------------------------------------------------------------------------------------------------------------------------------------------------------------------------------------------------------------------------------------------------------------------------------------------------------------------------------------------------------------------------------------------------------------------------------------------------------------------------------------------------------------------------------------------------------------------------------------------------------------------------------------------------------------------------------------------------------------------------------------------------------------------------------------------------------------------------------------------------------------------------------------------------------------------------------------------------------------------------------------------------------------------------------------------------------------------------------------------------------------------------------------------------------------------------------------------------------------------------------------------------------------------------------------------------------------------------------------------------------------------------------------------------------------------------------------------------------------------------------------------------------------	--	-----

IEC 60950_1F-ATTACHMENT

Clause	Requirement + Test	Result - Remark	Verdict
--------	--------------------	-----------------	---------

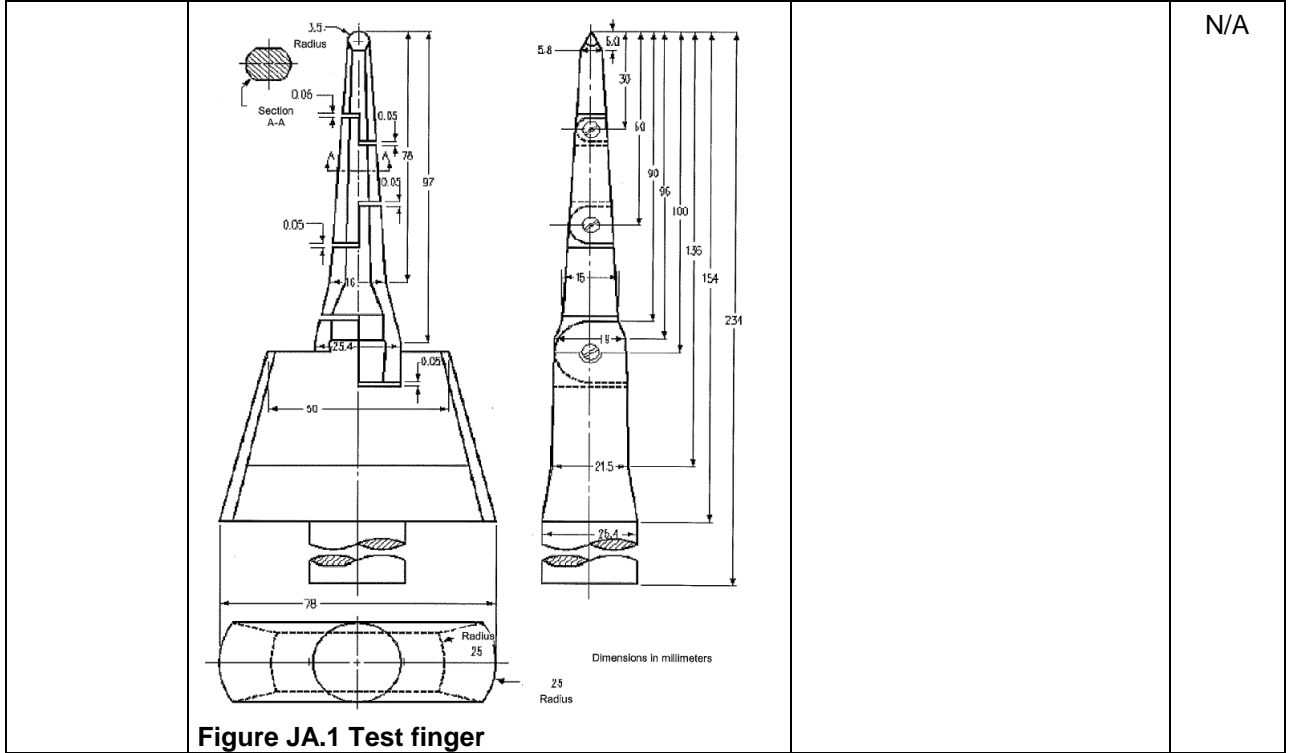

IEC 60950_1F-ATTACHMENT

Clause	Requirement + Test	Result - Remark	Verdict
--------	--------------------	-----------------	---------

	<p>(Details of the tip of wedge)</p> <table border="1" style="margin-left: auto; margin-right: auto;"> <thead> <tr> <th>Distance from the tip (mm)</th> <th>Thickness of probe (mm)</th> </tr> </thead> <tbody> <tr> <td>0</td> <td>2</td> </tr> <tr> <td>12</td> <td>4</td> </tr> <tr> <td>180</td> <td>24</td> </tr> </tbody> </table> <p>Note 1 - The thickness of the probe varies linearly, with slope changes at the respective points shown in the table. Note 2 -The allowable dimensional tolerance of the probe is +/- 0.127 mm.</p> <p>Figure JA.2 Wedge-probe</p>	Distance from the tip (mm)	Thickness of probe (mm)	0	2	12	4	180	24		N/A
Distance from the tip (mm)	Thickness of probe (mm)										
0	2										
12	4										
180	24										

Appendix I Photograph of the Equipment under test (EUT)

Model: GT-43006-***-T2(Class II)

Outer view of EUT(for inlet C8 type)



Outer view of EUT(for inlet C8 type)



Internal view of model 43006-2415-T2

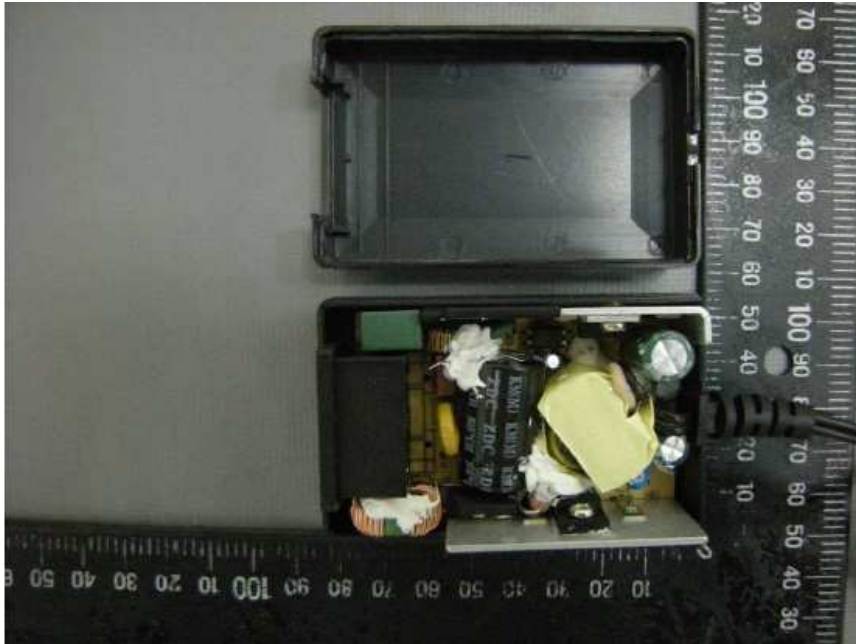

Internal view of model 43006-2415-T2

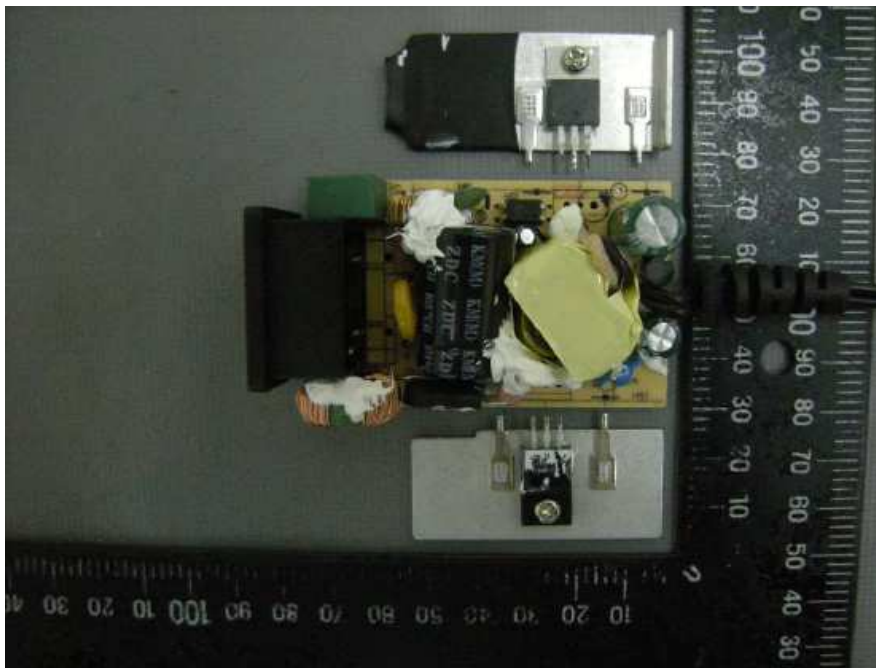

Internal view of model 43006-2415-T2

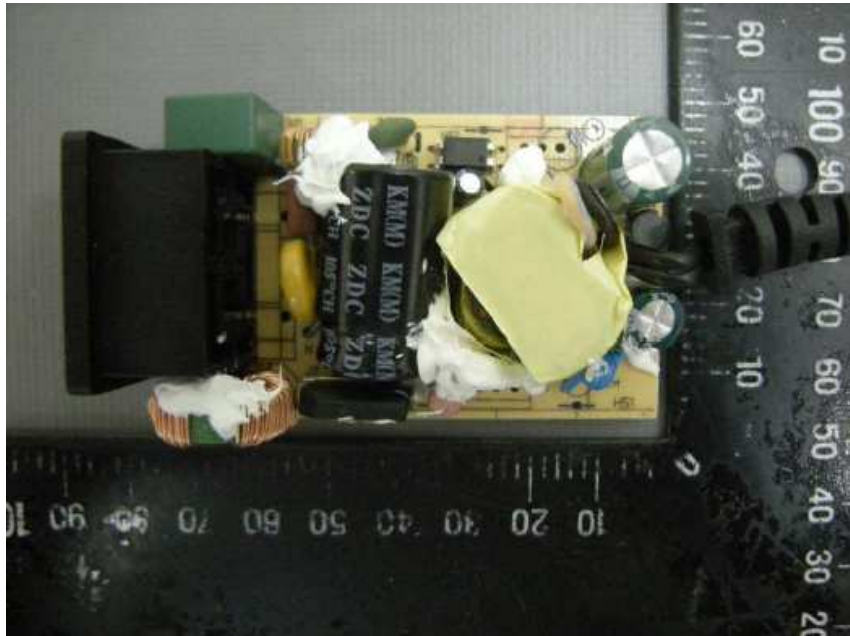

Internal view of model 43006-2415-T2



Internal view of model 43006-4048-T2



Internal view of model 43006-4048-T2

Internal view of model 43006-4048-T2

Internal view of model 43006-4048-T2

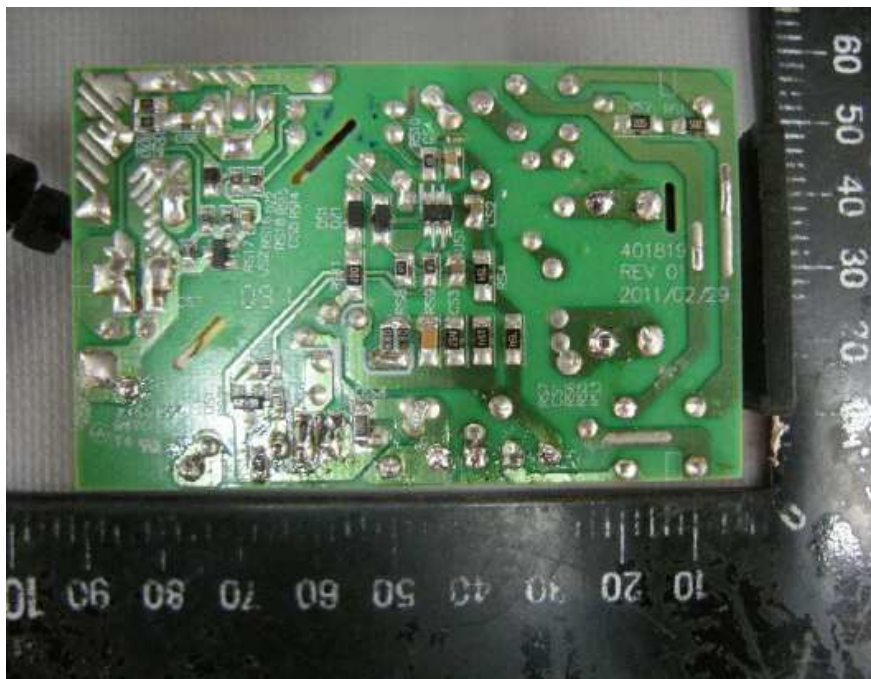

Model: Model: GT- 43006-***-T3 (Class I)

Outer view of model GT-43006-***-T3



Outer view of EUT (for inlet C14 type)



Outer view of EUT (for inlet C6 type)



Internal view of model GT-43006-2415-T3



Internal view of model GT-43006-2415-T3

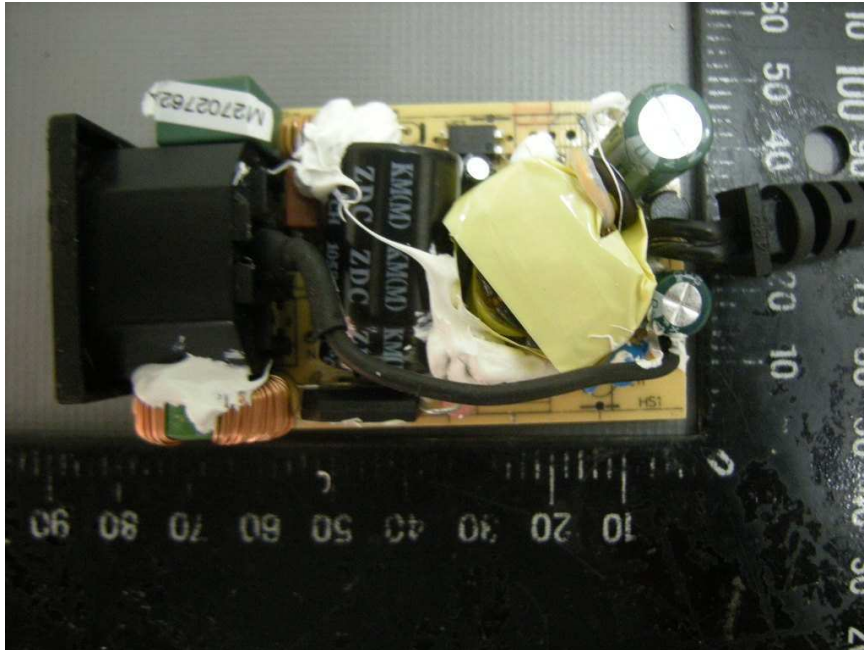

Internal view of model GT-43006-2415-T3

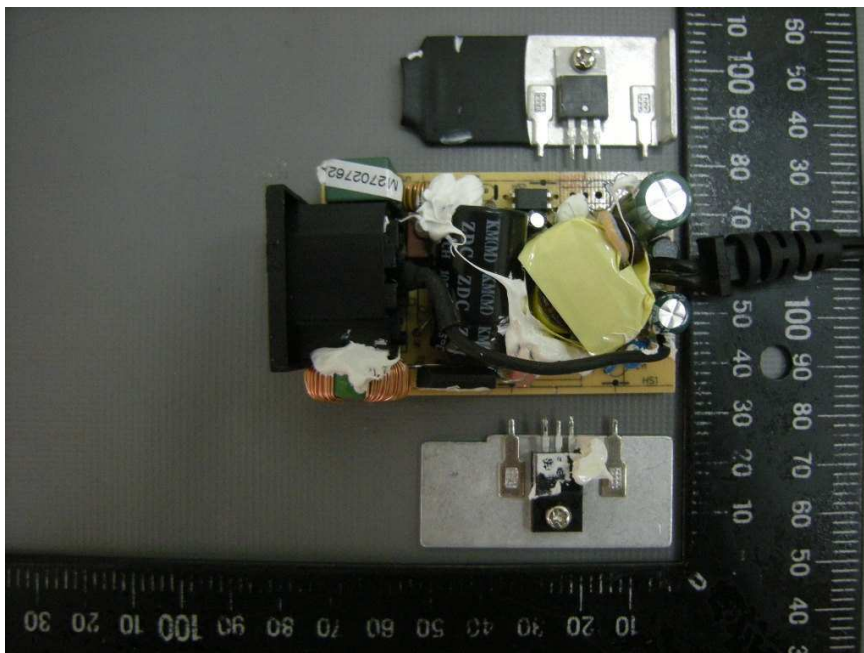

Internal view of model GT-43006-2415-T3

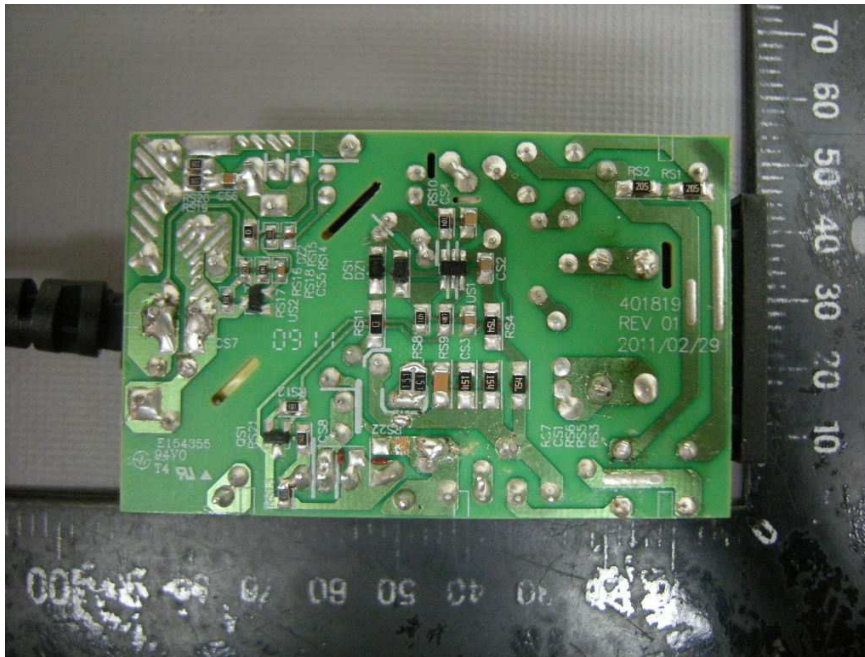

Internal view of EUT model GT-43006-4048-T3

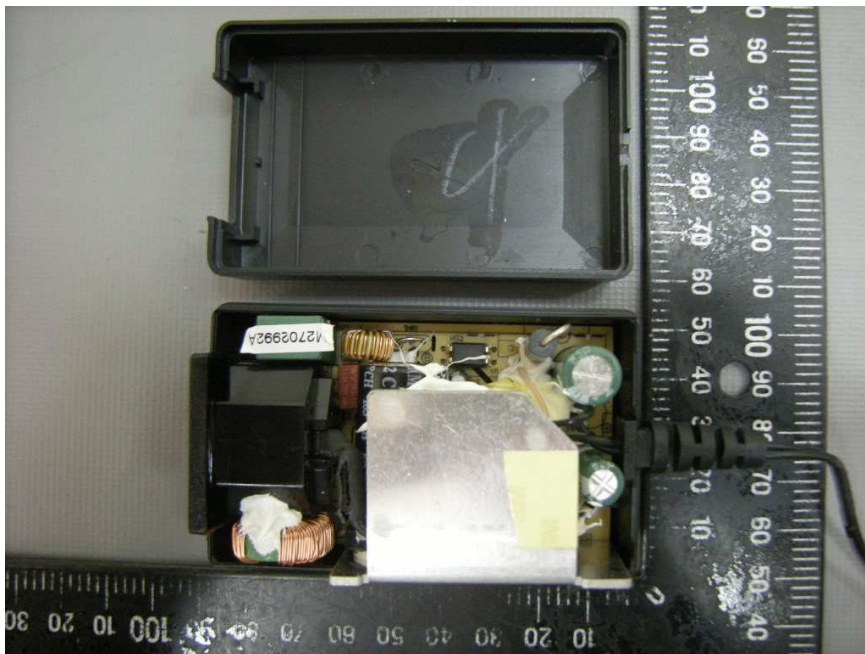



Internal view of EUT model GT-43006-4048-T3

Internal view of EUT model GT-43006-4048-T3

Internal view of EUT model GT-43006-4048-T3

