

UL TEST REPORT AND PROCEDURE

Standard:	UL 60950-1, 2nd Edition, 2014-10-14 (Information Technology Equipment - Safety - Part 1: General Requirements) CAN/CSA C22.2 No. 60950-1-07, 2nd Edition, 2014-10 (Information Technology Equipment - Safety - Part 1: General Requirements)
Certification Type:	Listing
CCN:	QQGQ, QQGQ7 (Power Supplies for Information Technology Equipment Including Electrical Business Equipment)
Product:	ITE POWER SUPPLY
Model:	GT-46180-WWVV-X.XX series, GT-41052-WWVV-X.XX [EL6] series, GT-41062-WWVV-X.XX [EL6] series, GT-41080-WWVV-X.XX [EL6] series and GT-41081-WWVV-X.XX [EL6] series WW is the standard output wattage, with a maximum value of "18", VV is the standard rated output voltage designation, with a maximum value of "24"; which can be 05,09,12,15,18,24. -X.XX denote the output voltage differentiator, subtracting X.XX volts from standard output voltage VV in 0.01V increments, the actual output voltage range is 5-24V, blank is to indicate the no voltage different.
Rating:	INPUT: 100-240 V ac , 50-60 Hz, 0.6A OUTPUT: See Miscellaneous 7-01 for details.
Applicant Name and Address:	GLOBTEK (HONG KONG) LTD UNIT 1402, BENSON TOWER 74 HUNG TO RD KWUN TONG KOWLOON HONG KONG

This is to certify that representative samples of the products covered by this Test Report have been investigated in accordance with the above referenced Standards. The products have been found to comply with the requirements covering the category and the products are judged to be eligible for Follow-Up Service under the indicated Test Procedure. The manufacturer is authorized to use the UL Mark on such products which comply with this Test Report and any other applicable requirements of UL LLC ('UL') in accordance with the Follow-Up Service Agreement. Only those products which properly bear the UL Mark are considered as being covered by UL's Follow-Up Service under the indicated Test Procedure.

The applicant is authorized to reproduce the referenced Test Report provided it is reproduced in its entirety.

Any information and documentation involving UL Mark services are provided on behalf of UL LLC (UL) or any authorized licensee of UL.

Prepared by: Vivian Chen

Reviewed by: Wei Chen

Supporting Documentation

The following documents located at the beginning of this Procedure supplement the requirements of this Test Report:

- A. Authorization - The Authorization page may include additional Factory Identification Code markings.
- B. Generic Inspection Instructions -
 - i. Part AC details important information which may be applicable to products covered by this Procedure. Products described in this Test Report must comply with any applicable items listed unless otherwise stated in the body of this Test Report.
 - ii. Part AE details any requirements which may be applicable to all products covered by this Procedure. Products described in this Test Report must comply with any applicable items listed unless otherwise stated in the body of each Test Report.
 - iii. Part AF details the requirements for the UL Certification Mark which is not controlled by the technical standard used to investigate these products. Products are permitted to bear only the Certification Mark(s) corresponding to the countries for which it is certified, as indicated in each Test Report.

Product Description

The product is a Direct plug-in equipment for Class II intended for use with Information Technology Equipment (ITE), there electronic components mounted on PWB, and housed in a thermoplastic enclosure by ultrasonic welding.

Model Differences

GT-41052-WWVV-X.XX [EL6] series, GT-41062-WWVV-X.XX [EL6] series, GT-41080-WWVV-X.XX [EL6] series and GT-41081-WWVV-X.XX [EL6] series are identical to Model GT-46180-WWVV-X.XX series except for Model designation.

Technical Considerations

- Equipment mobility : direct plug-in
- Connection to the mains : pluggable A
- Operating condition : continuous
- Access location : operator accessible
- Over voltage category (OVC) : OVC II
- Mains supply tolerance (%) or absolute mains supply values : +10%, -10%
- Tested for IT power systems : Yes
- IT testing, phase-phase voltage (V) : N/A
- Class of equipment : Class II (double insulated)
- Considered current rating of protective device as part of the building installation (A) : 20 A
- Pollution degree (PD) : PD 2
- IP protection class : IP X0
- Altitude of operation (m) : 2000
- Altitude of test laboratory (m) : 100
- Mass of equipment (kg) : 0.058
- The product was submitted and evaluated for use at the maximum ambient temperature (T_{ma}) permitted by the manufacturer's specification of: 40 degree C

- The means of connection to the mains supply is: Pluggable A
- The product is intended for use on the following power systems: TN
- The equipment disconnect device is considered to be: Plug
- The product was investigated to the following additional standards: The product was investigated to the following additional standards: The unit was evaluated to the maximum acceptable moment, center of gravity, dimensions and weight of the unit in accordance with UL 1310 and CSA C22.2 No. 223. The blade dimensions were evaluated to comply with NEMA configurations in accordance with Wiring Devices-Dimensional Specifications, ANSI/NEMA WD6.
- The following accessible locations (with circuit/schematic designation) are within a limited current circuit: Bridging Capacitor CY1 Secondary Part
- The following circuit locations (with circuit/schematic designation) were investigated as a limited power source (LPS): Output Connector
- The following are available from the Applicant upon request: Installation (Safety) Instructions / Manual

Additional Information

Additional Standards

The product fulfills the requirements of: N/A

Markings and instructions

Clause Title	Marking or Instruction Details
Power rating - Ratings	Ratings (voltage, frequency/dc, current)
Power rating - Company identification	Listee's or Recognized company's name, Trade Name, Trademark or File Number
Power rating - Model	Model Number
Fuses - Non-operator access/soldered-in fuses	Unambiguous reference to service documentation for instructions for replacement of fuses replaceable only by service personnel
Fuses - Rating	Rated current and voltage and type located on or adjacent to fuse or fuseholder.

Special Instructions to UL Representative

Inspect the transformer(s) listed in BD1.1 per AA1.1-(C).
 When the tests are conducted at other location, inspect test record and specification sheet provided by the component manufacturer. Verify the specification sheet indicates 100% routine test specified in BD1.1 be conducted at the component manufacturer.

Production-Line Testing Requirements						
<u>Electric Strength Test Special Constructions - Refer to Generic Inspection Instructions, Part AC for further information.</u>						
Model	Component	Removable Parts	Test probe location	V rms	V dc	Test Time, s
All Models	Transformer T1	N/A	Pri.-Sec.	300 0	4242	1
All Models	Unit	N/A	Pri.-Sec.	300 0	4242	1
<u>Earthing Continuity Test Exemptions - This test is not required for the following models:</u>						
All Models.						
<u>Electric Strength Test Exemptions - This test is not required for the following models:</u>						
N/A						
<u>Electric Strength Test Component Exemptions - The following solid-state components may be disconnected from the remainder of the circuitry during the performance of this test:</u>						
N/A						
<u>Sample and Test Specifics for Follow-Up Tests at UL</u>						
Model	Component	Material	Test	Sample(s)	Test Specifics	
N/A						

1.5.1	TABLE: list of critical components					Pass
Object/part or Description	Manufacturer/ trademark	type/model	technical data	Product Category CCN(s)	Required Marks of Conformity	Supplement ID
01. Enclosure and Replaceable plug holder material	SABIC INNOVATIVE PLASTICS	SE1X(GG)(f1)	Two pieces construction, secured together by ultrasonic welding, rated V-1 or better, 105 degree C min. Minimum 2.0 mm thickness. See Enclosure/Diagram ID 4-01 for dimensions	QMFZ2	UL	
02. Input Blades	Various	Various	Solid copper, non-grounding, non-polarized, NEMA 1-15P configuration, integrally moulded on Bottom Enclosure. Spaced minimum 5.1 mm from perimeter edge of Enclosure.	--	--	
03. Label	Various	Various	Minimum 65 degree C. if maximum surface temperature not specified.	PGDQ2, PGJ12	UL	
04. Output Cable	Various	Various	Rated Minimum 30 V, Minimum 80 degree C, Maximum 3.05 m long, marked VW-1 or FT-1. Terminates with a polarized connector outside enclosure.	AVLV2	UL	
05. Output Cable Strain Relief	Various	Various	PVC bushing integrally molded on output cord. See Enclosure - Diagrams 4-06 for dimensions details.	--	--	
06. PWB	Various	Various	V-0 or better, minimum 130 degree C.	ZPMV2	--	
07. Fuse (FS1)	Various	Various	T1.6A, 250Vac	JDYX	UL, C-UL	
07a. Fuse (FS1) (Alternate)	CONQUER ELECTRONICS CO LTD	MST	T1.6A, 250Vac	JDYX2	UL, C-UL	
07b. Fuse (FS1) (Alternate)	EVER ISLAND ELECTRIC CO LTD	2010	T1.6A, 250Vac	JDYX2	UL, C-UL	

	& WALTER ELECTRIC					
07c. Fuse (FS1) (Alternate)	HOLLYLAND CO LTD	5ET	T1.6A, 250Vac	JDYX2	UL, C-UL	
07d. Fuse (FS1) (Alternate)	BEL FUSE INC	RST	T1.6A, 250Vac	JDYX2	UL, C-UL	
07e. Fuse (FS1) (Alternate)	LITTELFUSE WICKMANN WERKE	392	T1.6A, 250Vac	JDYX2	UL, C-UL	
08. Varistor (MV1) (optional)	CENTRA SCIENCE CORP	CNR 14V511K	Rated minimum 300 Vac, minimum 385 Vdc.	VZCA2	UL, C-UL	
08a. Varistor (MV1) (optional) (Alternate)	CENTRA SCIENCE CORP	CNR 10V471K, CNR 14D471K	Rated minimum 300 Vac, minimum 385 Vdc.	VZCA2	UL, C-UL	
08b. Varistor (MV1) (optional) (Alternate)	CENTRA SCIENCE CORP	CNR 14D511K	Rated minimum 300 Vac, minimum 385 Vdc.	VZCA2	UL, C-UL	
08c. Varistor (MV1) (optional) (Alternate)	JOYIN CO LTD	10N511K, 10N471K	Rated minimum 300 Vac, minimum 385 Vdc.	VZCA2	UL, C-UL	
08d. Varistor (MV1) (optional) (Alternate)	JOYIN CO LTD	14N471K, 14N511K, 14S511K	Rated minimum 300 Vac, minimum 385 Vdc.	VZCA2	UL, C-UL	
08e. Varistor (MV1) (optional) (Alternate)	THINKING ELECTRONIC INDUSTRIAL CO LTD	TVR 10471K, TVR 10511K, TVR 10471-V	Rated minimum 300 Vac, minimum 385 Vdc.	VZCA2	UL, C-UL	
08f. Varistor (MV1) (optional) (Alternate)	THINKING ELECTRONIC INDUSTRIAL CO LTD	TVR 14471K, TVR 14511K	Rated minimum 300 Vac, minimum 385 Vdc.	VZCA2	UL, C-UL	
08g. Varistor (MV1) (optional) (Alternate)	CERAMATE TECHNICAL CO LTD	GNR 14D471K, GNR 14D511K	Rated minimum 300 Vac, minimum 385 Vdc.	VZCA2	UL, C-UL	
08h. Varistor (MV1) (optional) (Alternate)	CERAMATE TECHNICAL CO LTD	GNR10D471K	Rated minimum 300 Vac, minimum 385 Vdc.			
08i. Varistor (MV1) (optional) (Alternate)	SUCCESS ELECTRONICS CO LTD	SVR10D471K, SVR10D511K	Rated minimum 300 Vac, minimum 385 Vdc.	VZCA2	UL, C-UL	
08j. Varistor (MV1) (optional) (Alternate)	SUCCESS ELECTRONICS CO LTD	SVR14D471K, SVR14D511K	Rated minimum 300 Vac, minimum 385 Vdc.	VZCA2	UL, C-UL	

09. Bridge Diode (DB1)	--	--	Rated minimum 1A, minimum 800 V.	--	--	
10. Storage Capacitor (C1)	--	--	Rated 400 V, max. 33uF, min. 105 degree C, provided with integral pressure relief	--	--	
11. X-Capacitor (CX1)	Cheng Tung Industrial Co Ltd	CTX	Rated max 0.1 uF, min 250 V, X1 or X2 type, 100 degree C. (Compliance with IEC 60384-14)	FOWX2	UL	
11a. X-Capacitor (CX1) (Alternate)	Tenta Electric Industrial Co Ltd	MEX	Rated max 0.1uF, min 250 V, X1 or X2 type, 100 degree C. (Compliance with IEC 60384-14)	FOWX2	UL	
11b. X-Capacitor (CX1) (Alternate)	Ultra Tech Xiphi Enterprise Co Ltd	HQX	Rated max 0.1 uF, min 250 V, X1 or X2 type, 100 degree C. (Compliance with IEC 60384-14)	FOWX2	UL	
11c. X-Capacitor (CX1) (Alternate)	CARLI ELECTRONICS CO LTD	MPX	Rated max 0.1uF, min 250 V, X1 or X2 type, 100 degree C. (Compliance with IEC 60384-14)	FOWX2	UL	
11d. X-Capacitor (CX1) (Alternate)	JOEY ELECTRONICS (DONG GUAN) CO LTD	MPX	Rated max 0.1uF, min 250 V, X1 or X2 type, 105 degree C. (Compliance with IEC 60384-14)	FOWX2	UL	
11e. X-Capacitor (CX1) (Alternate)	XIANGTAI ELECTRONIC (SHENZHEN) CO LTD	MKP/MPX	Rated max 0.1uF, min 250 V, X1 or X2 type, 110 degree C. (Compliance with IEC 60384-14)	FOWX2	UL	
12. Transformer (T1) (For 5V models)		XF00914	Class B, See Enclosure / Diagram ID 4-07 for construction details.	--	--	
12. Transformer (T1) (For 9-15V models)		XF00915	Class B, See Enclosure / Diagram ID 4-08 for construction details.	--	--	
12. Transformer (T1) (For 18-24V models)		XF00934	Class B, See Enclosure / Diagram ID 4-09 for	--	--	

			construction details.			
12-01. Insulation system for Transformer (T1)		130-1	Insulation system Class B (130 degree C, adapted form GREAT LEOFLON INDUSTRIAL CO LTD, Type GH-130)	OBYJ2	UL	
12-02. Core	--	--	EE type, Ferrite, dimension 13.5 mm by 12.5mm by 6.0mm	--	--	
12-03. Coil	--	--	Min. 130 degree C	OBMW2	UL	
12-04. Bobbin	Chang Chun Plastics Co., Ltd.	T375J	V-0, 150 degree C, Phenolic, thickness 0.8mm minimum	QMFZ2	UL	
12-04a. Bobbin (Alternate)	SUMITOMO BAKELITE CO LTD	PM-9820	V-0, 150 degree C, Phenolic, thickness 0.71mm minimum	QMFZ2	UL	
12-05. Tubing/Sleeving	Great Holding Industrial Co. Ltd.	TFL, TFS, TFT	Rated 200 degree C, VW-1, 600V max.	YDPU2	UL	
12-06. Triple Insulated Wire	Great Leoflon Industrial Co. Ltd.	TRW(B)	130 degree C. (Used in secondary winding)	OBJT2	UL	
12-07. Varnish	John C. Dolph Co.	BC-346A	Rated minimum 200 degree C.	OBOR2	UL	
12-07a. Varnish (Alternate)	Elantas Electrical Insulation Elantas Pdg Inc	V1630FS	Rated minimum 130 degree C.	OBOR2	UL	
12-08. Insulation Tape	3M COMPANY ELECTRICAL MARKETS DIV (EMD)	1350F-(#), 1350T-1	130 degree C.	OANZ2	UL	
12-08. Insulation Tape (alternate)	BONDTEC PACIFIC CO LTD	370S	130 degree C.	OANZ2	UL	
13. Internal Glue Materials	--	--	Rated V-2 minimum.	QMFZ2	UL	
14. Internal Plastic Part Materials	--	--	Rated minimum V-2.	QMFZ2	UL	
15. Current sense resistor (RS12, RS13, RS14) (for 18-24V models)	--	--	3.3 ohm, 1/4W.	--	--	
15. Current sense	--	--	3.6 ohm, 1/4W.	--	--	

resistor (RS12, RS13, RS14) (for 18V models)						
15. Current sense resistor (RS13, RS14) (for 5V models)	--	--	3.3 ohm, 1/4W.	--	--	
15. Current sense resistor (RS13, RS14) (for 20V models)	--	--	3.6 ohm, 1/4W.	--	--	
15. Current sense resistor (RS12) (for 5V and 20V models)	--	--	4.7 ohm, 1/4W.	--	--	
16. Line filter (LF1) (Optional)	Various	NF00085	Open type construction. Rated 105 degree C.	--	--	
16a Core	Various	Various	Ferrite, overall measured overall 15.67 mm by 10.4mm by 2.8mm	--	--	
16b Coil	Various	Various	Rated minimum 105 degree C.	OBMW2	UL	
17. Bridge Capacitors (CY1) (optional)	Success Electronics Co Ltd	SE, SB	max. 1000pF, min. 250 Vac, 125 degree C, Y1 type. (Compliance with IEC 60384-14)	FOWX2	UL	
17a. Bridge Capacitors (CY1) (optional) (Alternate)	TDK-EPC CORPORATION	CD	rated max. 1000pF, min. 250 Vac, 125 degree C, Y1 type. (Compliance with IEC 60384-14)	FOWX2	UL	
17b. Bridge Capacitors (CY1) (optional) (Alternate)	Walsin Technology Corp	AH	max. 1000pF, min. 250 Vac, 125 degree C, Y1 type. (Compliance with IEC 60384-14)	FOWX2	UL	
17c. Bridge Capacitors (CY1) (optional) (Alternate)	Haohua Electronic Co	CT 7	rated max. 1000pF, min. 250 Vac, 125 degree C, Y1 type. (Compliance with IEC 60384-14)	FOWX2	UL	
17e. Bridge Capacitors (CY1) (optional) (Alternate)	XIANGTAI ELECTRONIC (SHENZHEN) CO LTD	YOB YOF YOE	rated max. 1000pF, min. 250 Vac, 125 degree C, Y1 type. (Compliance with IEC 60384-14)	FOWX2	UL	

17e. Bridge Capacitors (CY1) (optional) (Alternate)	JUHONG ELE CO	JB	rated max. 1000pF, min. 250 Vac, 125 degree C, Y1 type. (Compliance with IEC 60384-14)	FOWX2	UL	
18. Optical Isolator (U1)	Lite-On Technology Corp	LTV-817	Isolation: 5000 Vac, minimum 100 degree C.	FPQU2	UL	
18a. Optical Isolators (U1) (Alternate)	Everlight Electronics Co Ltd	EL817	Isolation: 5000 Vac, minimum 110 degree C.	FPQU2	UL	
18b. Optical Isolators (U1) (Alternate)	COSMO ELECTRONICS CORP	K1010	Isolation voltage minimum 5000 Vac, minimum 115 degree C.	FPQU2	UL	
18c. Optical Isolators (U1) (Alternate)	BRIGHT LED ELECTRONICS CORP	BPC-817XXXXXX, BPC-817MXXXXXX, BPC-817SXXXXXX, where XXXXXX can be any alphanumeric character or blank.	Isolation voltage minimum 5000 Vac, minimum 100 degree C.	FPQU2	UL	
18d. Optical Isolators (U1) (Alternate)	RENESAS ELECTRONICS CORPORATION	PS2561-1	Isolation voltage minimum 5000 Vac, minimum 100 degree C.	FPQU2	UL	
19. Transistor (Q1)	Various	Various	Rated 4-10 A, minimum 600 V.	--	--	
20. Heat Sink (HS1) (Consideration as Primary)	Various	Various	Aluminum, minimum 1.5 mm thick. See Enclosure 4-02 for detailed dimensions.	--	--	
21. Heat Sink (HS2) (Consideration as Secondary) (for models GT-46180-1505, GT-46180-1809, GT-46180-1812)	Various	Various	Aluminum, minimum 1.2 mm thick. See Enclosure 4-03 for detailed dimensions.	--	--	

Issue Date: 2015-08-11

Page 11 of 12

Report Reference #

E341351-A70-UL

Enclosures

<u>Type</u>	<u>Supplement Id</u>	<u>Description</u>
Diagrams	4-01	Enclosure Construction
Diagrams	4-02	Heatsink HS1 Construction
Diagrams	4-03	Heatsink HS2 Construction
Diagrams	4-04	Choke LF1 Spec.
Diagrams	4-05	Direct Plug in 1-15P Construction
Diagrams	4-06	Strain Relief Drawing
Diagrams	4-07	Transformer T1 Spec (P/N. XF00914)
Diagrams	4-08	Transformer T1 Spec (P/N. XF00915)
Diagrams	4-09	Transformer T1 Spec (P/N. XF00934)
Schematics + PWB	5-01	PWB Layout
Miscellaneous	7-01	Model Differences and Ratings Table
Miscellaneous	7-02	CB Test Report
Miscellaneous	7-03	CB Certificate

Att.2

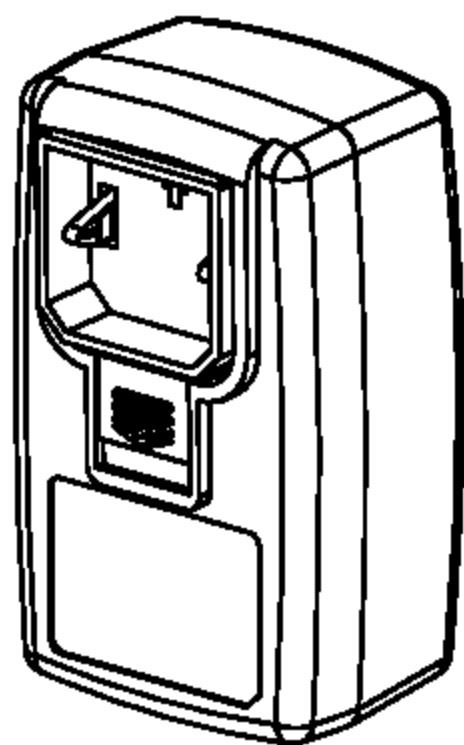
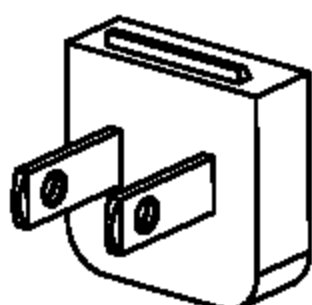
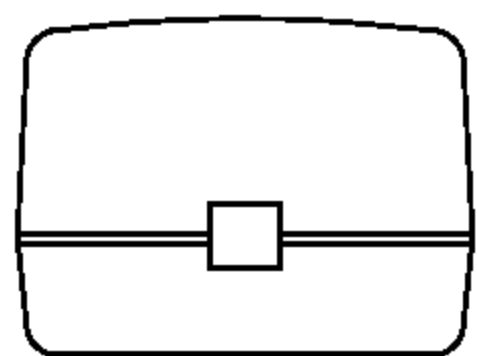
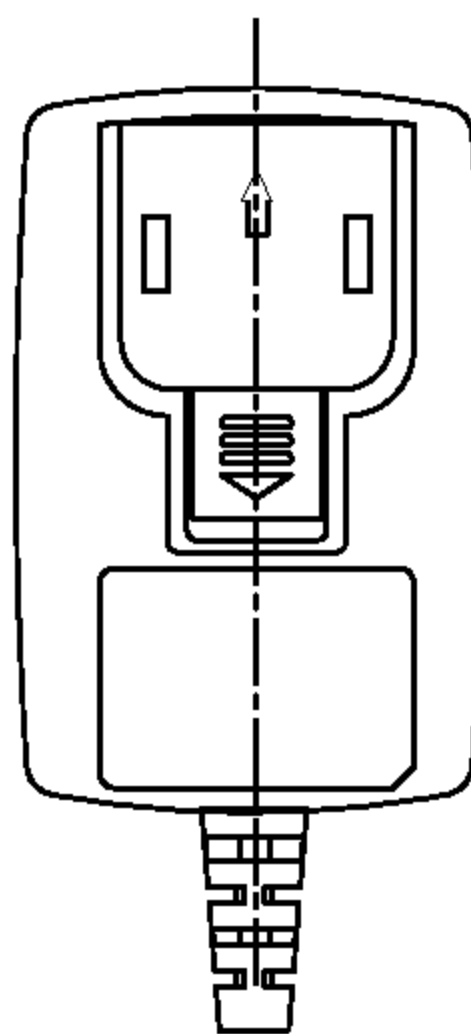
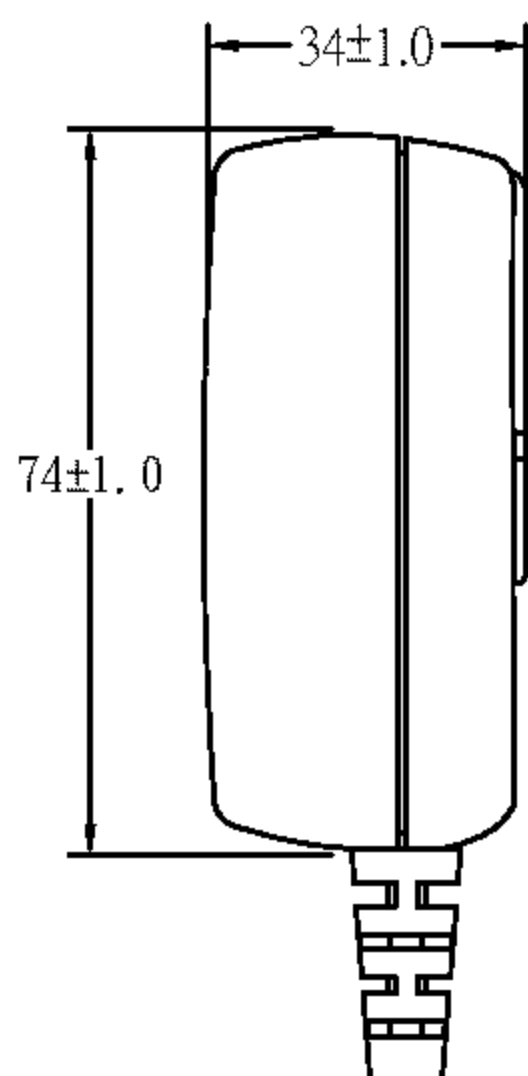
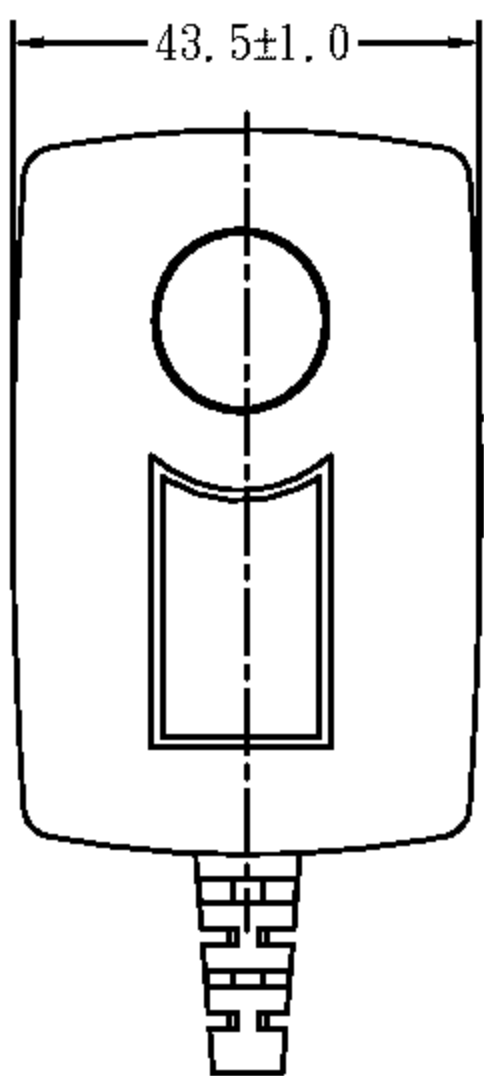

TOLERANCE

DESIGNED	CHECKED	APPROVED		TITLE	DATE
XiaoRW	ChenKZ	ChenXQ		OUTDRAWING	8/19-14
			UNITS	DRAWING No.	REVISION
			mm	1007	
			SCALE	DRAWING NAME	01

Att.

項次	變更記錄	備注
△	長度減短到30.0mm	150109
△		
△		

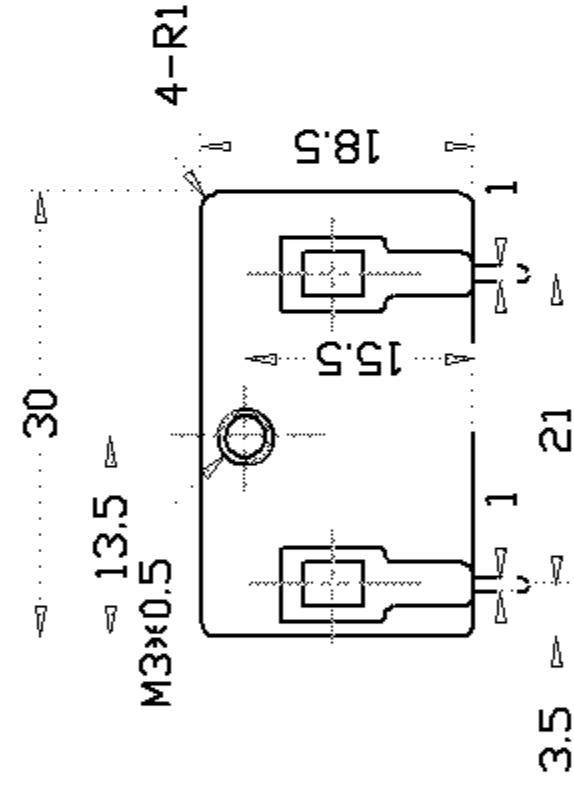
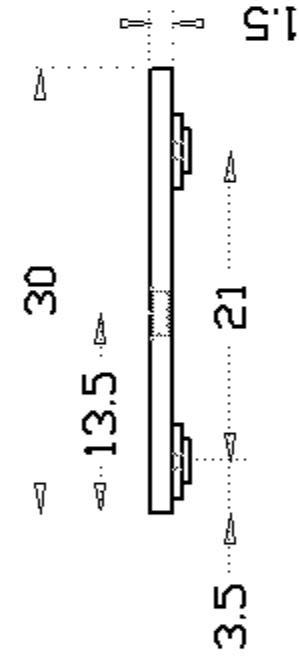

技术要求

- 1.材料:鋁材1.5mm.
- 2.表面須平整,光潔,不得有划伤和毛边.
- 3.攻牙孔須正面倒角0.3mm.

TOLERANCE

>100	70-100	40-70	10-40	10-Less	其他
±0.5	±0.3	±0.2	±0.15	±0.1	根據一般公差

DESIGNED	CHECKED	APPROVED	TITLE	DATE
XiaoRW	ChenKZ	ChenXQ	HS	
UNITS mm			DRAWING No.	10/14-14
SCALE 1:1			HO2-181825-001	REVISION 1.1
			DRAWING NAME	

Att.

項次	變更記錄	備注
△	切除1.0mm	141014
△		
△		

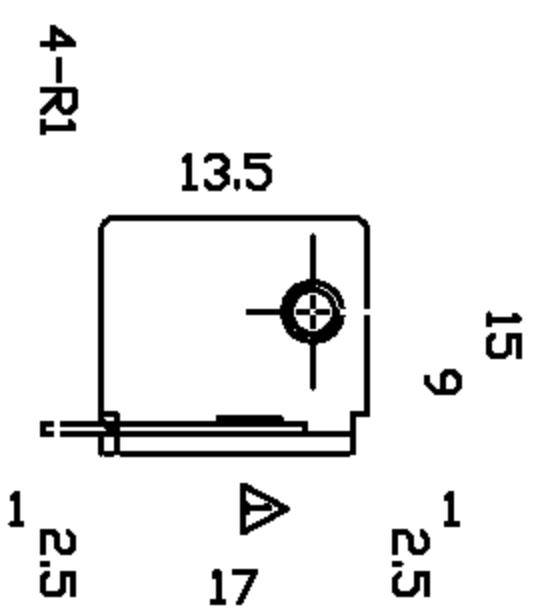
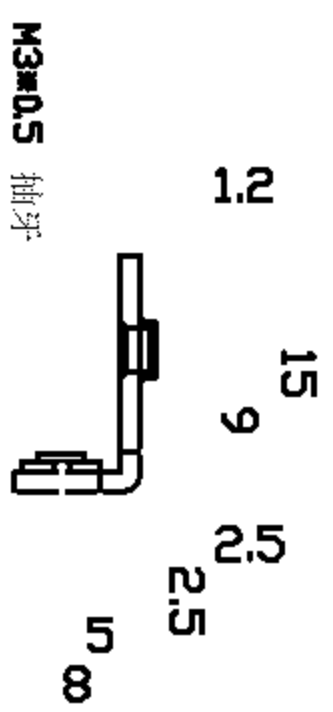

TOLERANCE					
>100	70-100	40-70	10-40	10-Less	其他
±0.5	±0.3	±0.2	±0.15	±0.1	依照一般公差

TITLE	DATE
HS	

DRAWING No.	DATE
HO2-181825-002	08/05-14

DRAWING NAME	REVISION
	1.1

- 技术要求**
- 1.材料:鋁材1.2mm抽牙孔.
 - 2.表面須平整,光潔,不得有划伤和毛邊.

DESIGNED	CHECKED	APPROVED	UNITS	SCALE
XiaoRW	XiaoDH	ChenXQ	mm	1:1

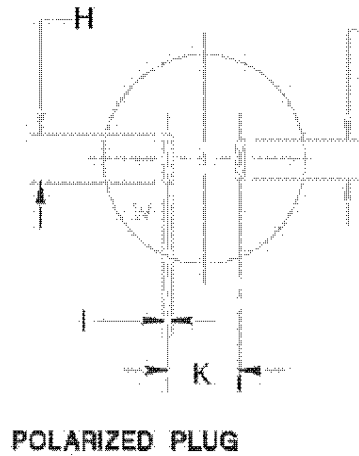
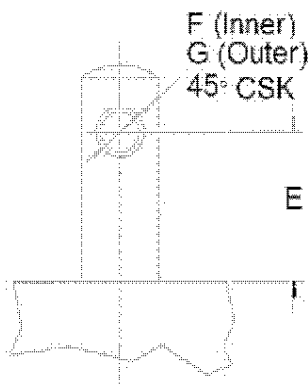
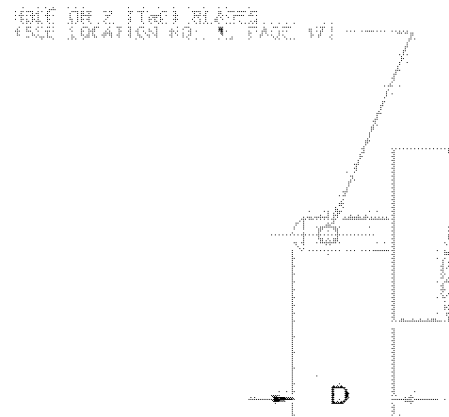
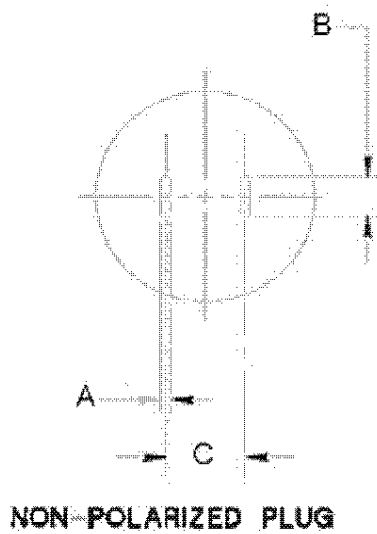
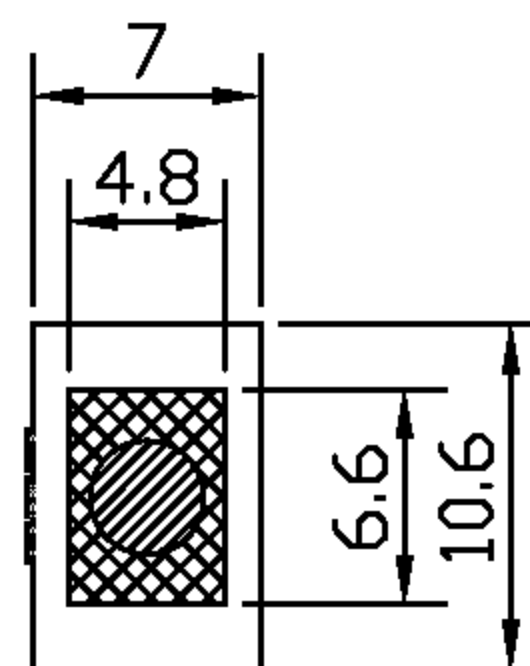
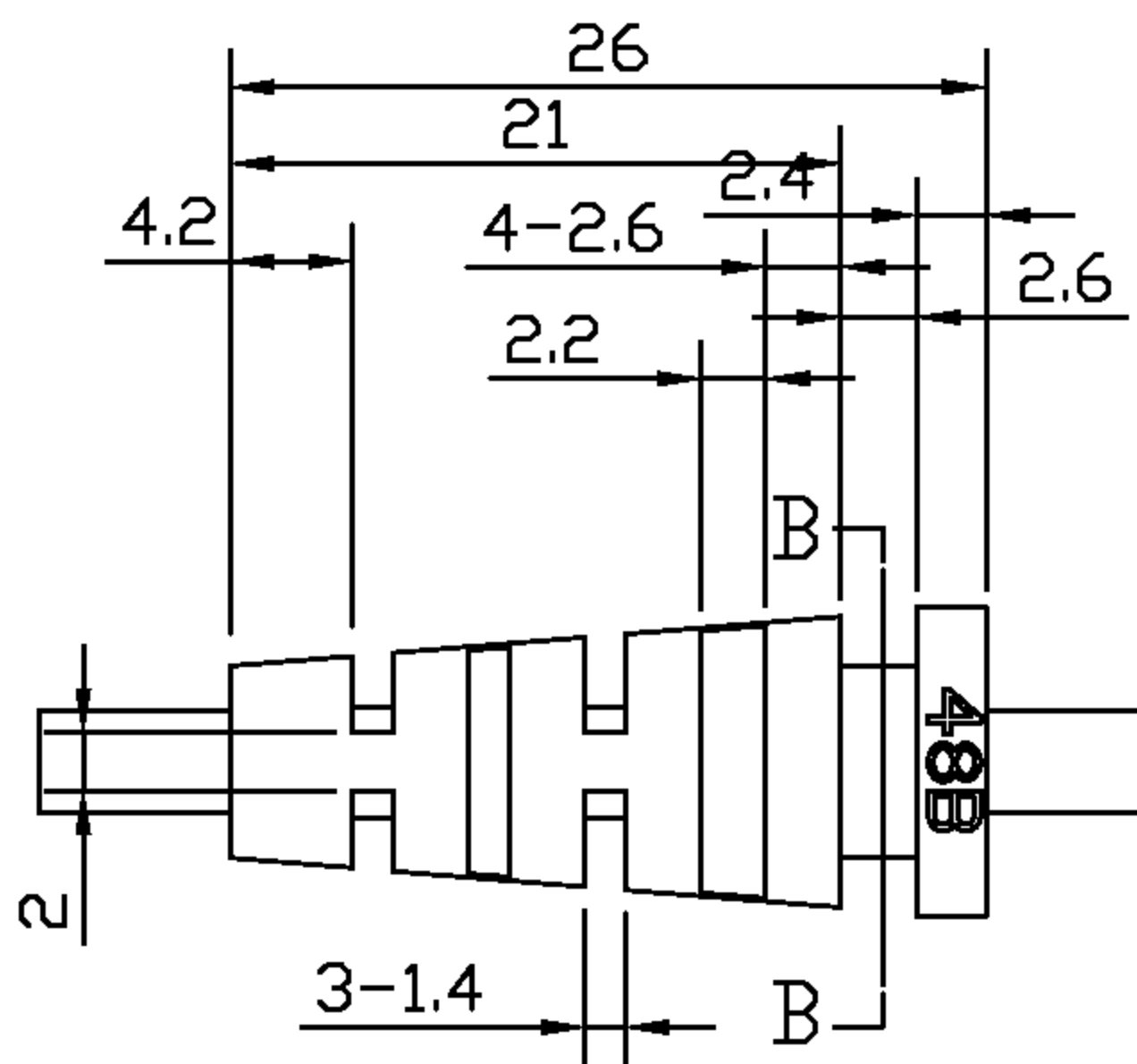
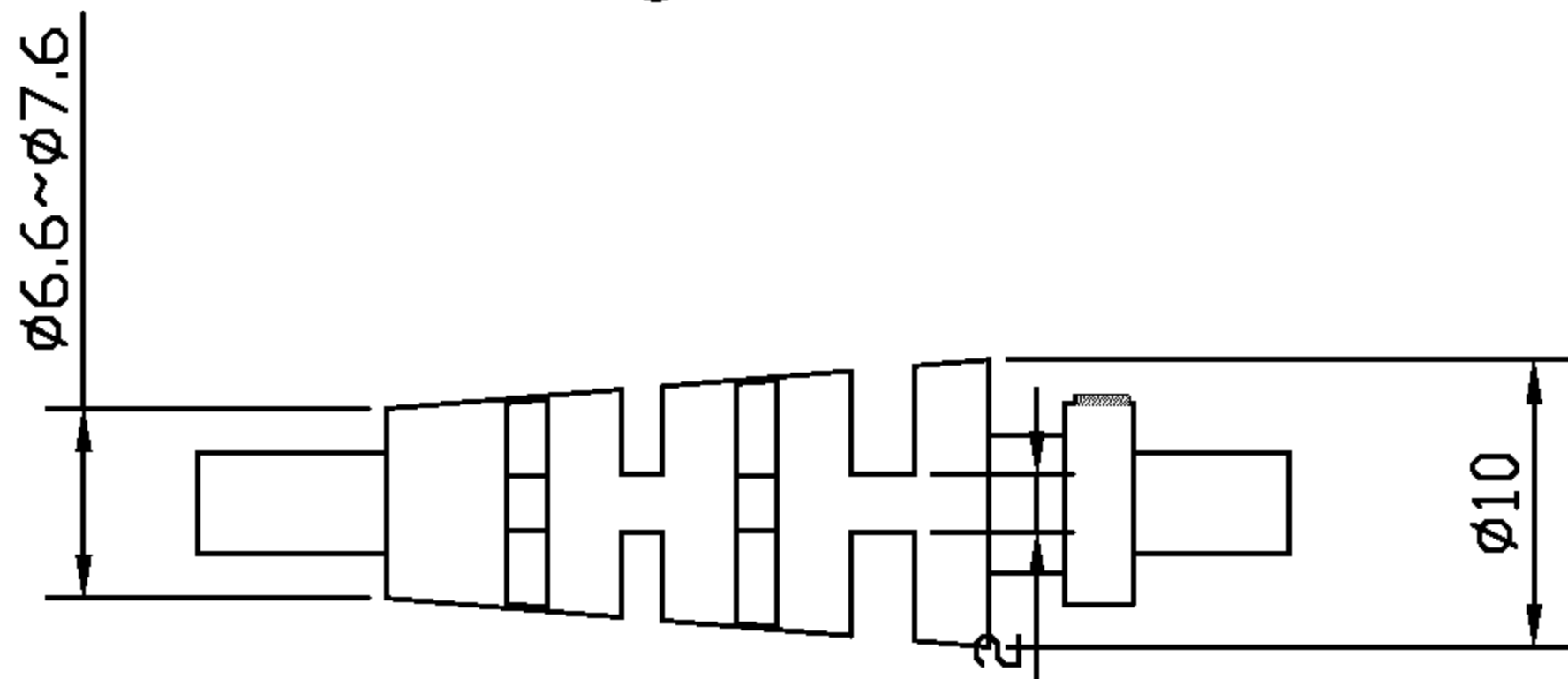
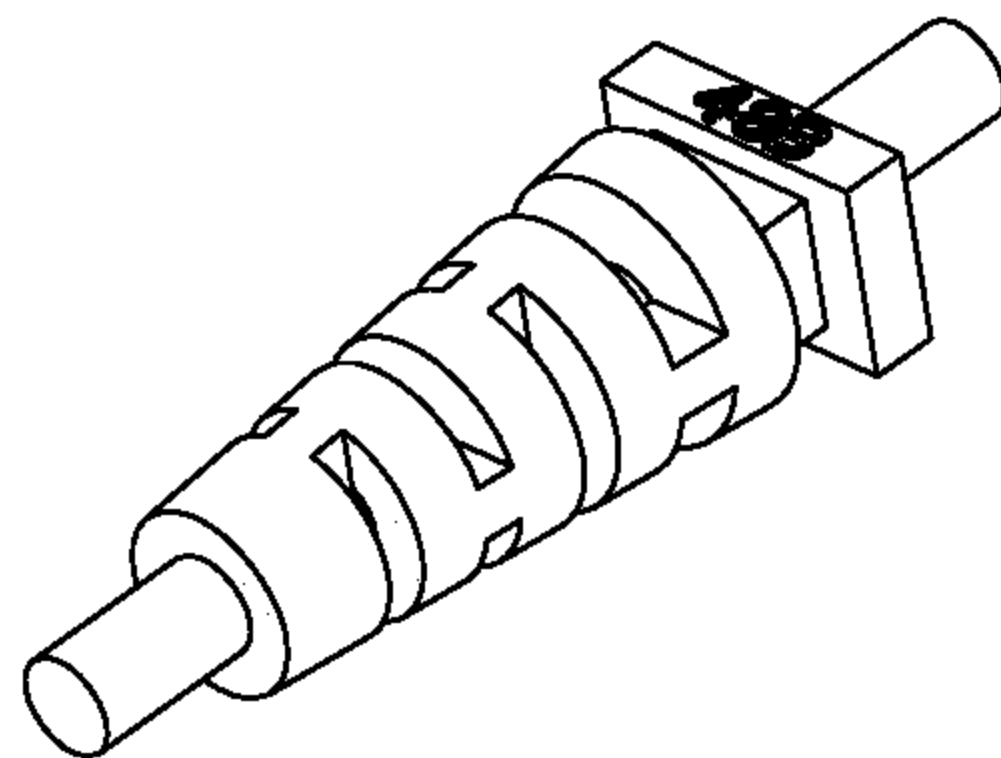

TABLE: North American plug dimension according to NEMA 1-15P				Verdict
Location	Dimensions (mm)	Measurement (mm)	Limit (mm)	--
A, I	Thickness of live pin		1.524 ^{±0.127} (1.397 - 1.651)	P
B, J	Width of live pin		6.096 – 6.604	P
C, K	Distance between two live pins (center)		12.70 ^{±0.127} (12.573 - 12.827)	P
D	Length of live pins		15.875 – 18.237	P
E	Distance between hole center and plug face (if hole used)		11.786 ^{±0.381} (11.405 - 12.167)	P
F	Inner diameter of hole (if hole used)		3.175 ^{±0.127} (3.048 - 3.302)	P
G	Outer diameter of hole (if hole used)		3.962 ^{±0.127} (3.835 - 4.089)	P
H	Width of wider live pin	--	7.798 – 8.179	N/A

Note: P= Pass; F=Fail; N/A= Not Applicable.



線材OD: $\phi 1.5 \times 3.0$; $\phi 1.7 \times 3.4$; $\phi 3.0$; $\phi 3.5$
 $\phi 1.8 \times 3.6$; $\phi 1.9 \times 3.8$
 @3A-261DA12-093增開OD2.2*4.4
 09/11/12新增開OD2.6X5.2(16#AWG UL2468)

未標示圓角R0.2mm

TOLERANCE

>0.5~<0.3	3.0~<6.0	6.0~<30	30~<120	120~<400
±0.1	±0.15	±0.2	±0.3	±0.4

DESIGNED	CHECKED	APPROVED		TITLE	SR	DATE
GuanJing	liu min	zhu rg		UNITS	DRAWING No.	R48B
				SCALE	DRAWING NAME	REVISION
					48B	01

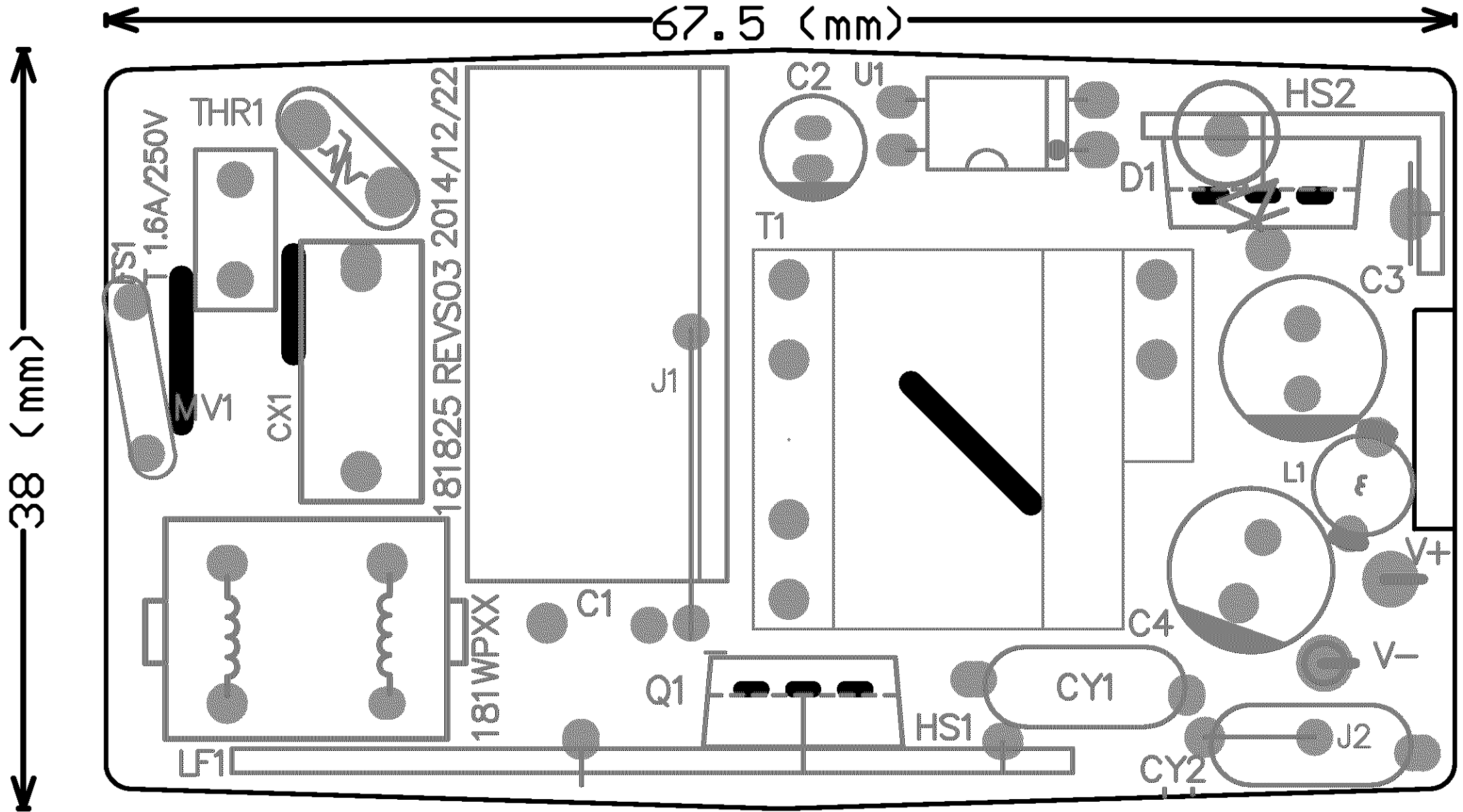

PCB=CEM-1/1.6mm/10Z

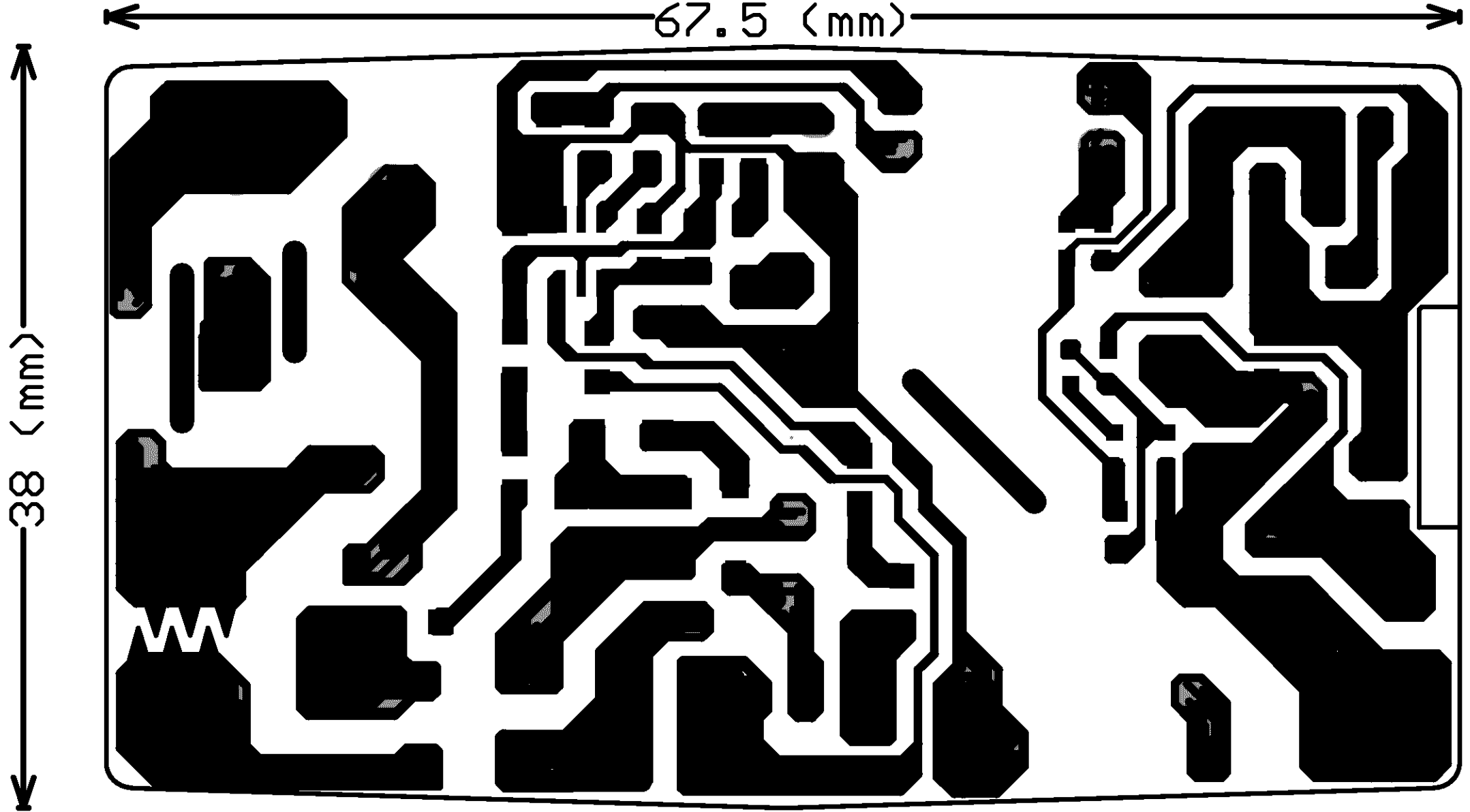

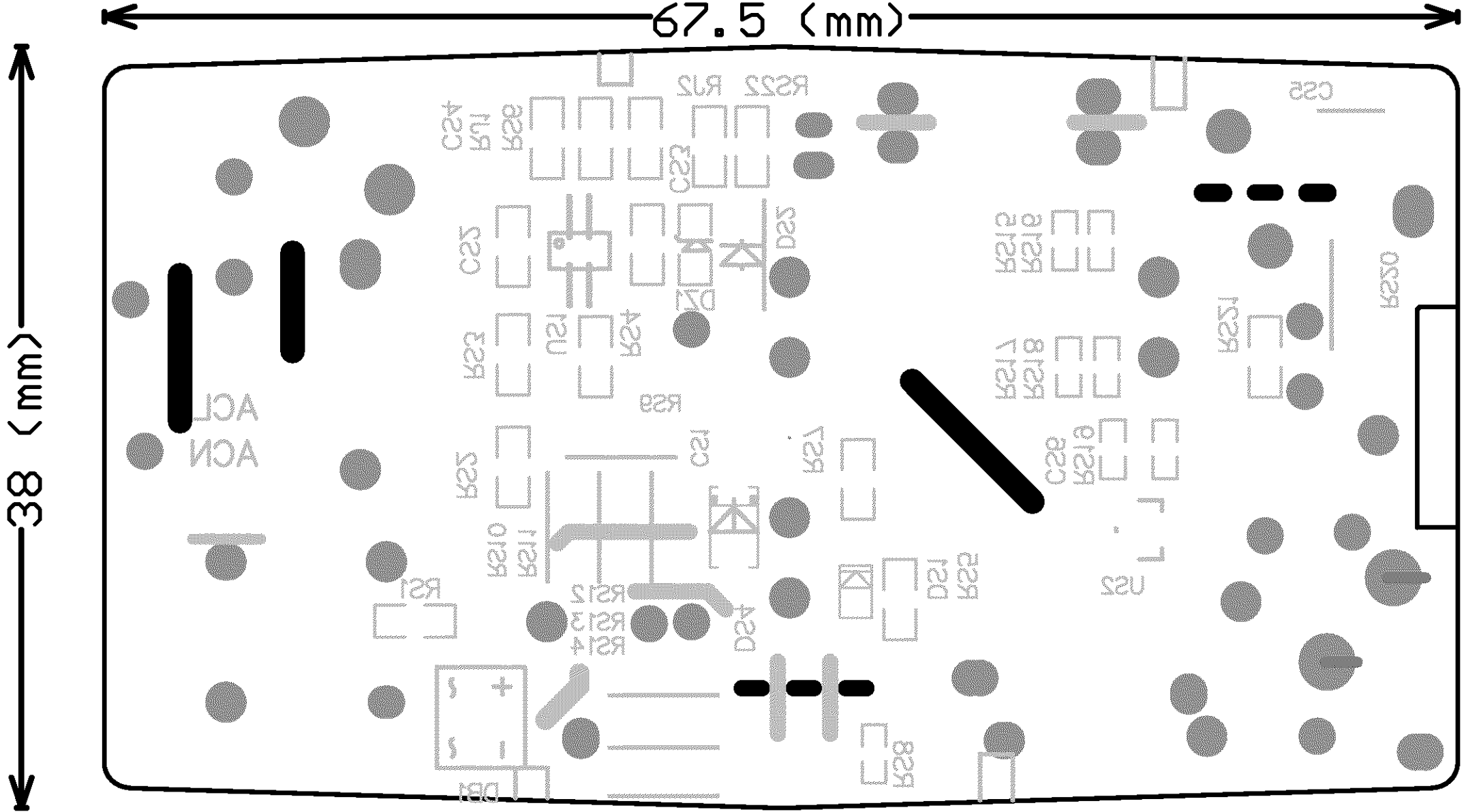

Old Model name	GT model name	Output voltage	Output current	Max.W
6A-181WPxx, 6A-161WPxx (where xx can be 05, 09, 12, 15, 18, 20 or 24 for output voltage) INPUT: 100-240 V ac , 50-60 Hz, 0.6A	GT-46180-WWVV-X.XX series WW is the standard output wattage, with a maximum value of "18", VV is the standard rated output voltage designation, with a maximum value of "24"; which can be 05, 09, 12, 15, 18, 24. -X.XX denote the output voltage differentiator, subtracting X.XX volts from standard output voltage VV in 0.01V increments, the actual output voltage rang is 5-24V, blank is to indicate the no voltage different.			
6A-181WP05	GT-46180-1505	5V	3.0A	15W
6A-181WP09	GT-46180-1809	9V	2.0A	18W
6A-181WP12	GT-46180-1812	12V	1.5A	18W
6A-181WP15	GT-46180-1815	15V	1.2A	18W
6A-181WP18	GT-46180-1818	18V	1.0A	18W
6A-181WP20	GT-46180-1824-4.0	20V	0.9A	18W
6A-181WP24	GT-46180-1824	24V	0.75A	18W
6A-161WP05	GT-46180-1305	5V	2.6A	13W
6A-161WP09	GT-46180-1509	9V	1.66A	15W
6A-161WP12	GT-46180-1512	12V	1.25A	15W
6A-161WP15	GT-46180-1515	15V	1.0A	15W
6A-161WP18	GT-46180-1518	18V	0.83A	15W
6A-161WP20	GT-46180-1524-4.0	20V	0.75A	15W
6A-161WP24	GT-46180-1524	24V	0.625A	15W

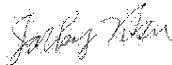
Testing procedure and testing location:	
<input checked="" type="checkbox"/> CB Testing Laboratory:	
Testing location/ address.....:	PSE INC. TAIWAN / 9F-1, No.80, Sec. 2, Guang Fu Rd., San Chung Distr., New Taipei City, Chinese Taipei
<input type="checkbox"/> Associated CB Testing Laboratory:	
Testing location/ address.....:	
Tested by (name + signature).....:	Mike Tsai 
Approved by (name + signature).....:	Jacky Hsu 
<input type="checkbox"/> Testing procedure: TMP/CTF Stage 1:	
Testing location/ address.....:	
Tested by (name + signature).....:	
Approved by (name + signature).....:	
<input type="checkbox"/> Testing procedure: WMT/CTF Stage 2:	
Testing location/ address.....:	
Tested by (name + signature).....:	
Witnessed by (name + signature).....:	
Approved by (name + signature).....:	
<input type="checkbox"/> Testing procedure: SMT/CTF Stage 3 or 4:	
Testing location/ address.....:	
Tested by (name + signature).....:	
Witnessed by (name + signature).....:	
Approved by (name + signature).....:	
Supervised by (name + signature).....:	

List of Attachments (including a total number of pages in each attachment):

- 1) National Differences (59 pages)
 - 1) National Difference of IEC 60950-1:2005 (Second Edition) + Am 1: 2009 + Am 2: 2013
 - 2) National Difference of IEC 60950-1:2005 (Second Edition) + Am 1: 2009
 - 3) National Difference of IEC 60950-1:2005 (Second Edition)
 - 4) National Difference of IEC 60950-1:2001 (First Edition)
- 2) Photo (5 pages)

Summary of testing:

Unless otherwise indicated, all tests were conducted at PSE INC., TAIWAN / 9F-1, No. 80, Sec. 2, Guang Fu Rd., San Chung Distr., New Taipei City, Chinese Taipei

Tests performed (name of test and test clause): Testing location:

1.6.2 INPUT TEST: SINGLE-PHASE
 1.7.11 DURABILITY OF MARKING TEST
 2.1.1.5, 2.1.2, 1.2.8.10 ENERGY HAZARD MEASUREMENTS
 2.2.2, 2.2.3, 2.2.4, PART 22 6.1 SELV RELIABILITY TEST INCLUDING HAZARDOUS VOLTAGE MEASUREMENTS
 2.4.1, 2.4.2 LIMITED CURRENT CIRCUIT MEASUREMENTS
 2.5 LIMITED POWER SOURCE MEASUREMENTS
 2.9.1, 2.9.2, 5.2.2 HUMIDITY TEST.
 2.10.2 DETERMINATION OF WORKING VOLTAGE - WORKING VOLTAGE MEASUREMENT TEST
 2.10.5.9, 2.10.5.10, 2.10.5.6 – THIN SHEET MATERIAL TESTS
 2.10.5.6, 2.10.5.13 TRANSFORMER AND WIRE INSULATION ELECTRIC STRENGTH TEST
 4.2.1 - 4.2.4 STEADY FORCE TESTS
 4.2.6, 4.2.1 DROP TEST
 4.2.7, 4.2.1 STRESS RELIEF TEST
 4.3.6 DIRECT PLUG IN EQUIPMENT-MOMENT TEST
 4.3.6 WEIGHT AND MOMENT DETERMINATION: (DIRECT PLUG-IN UNIT)
 4.3.6 DIRECT PLUG-IN BLADE SECUREMENT TEST
 4.3.6 DIRECT PLUG-IN SECURITY OF INPUT CONTACTS
 4.3.6 DIRECT PLUG-IN RESISTANCE TO CRUSHING
 4.3.6 DIRECT PLUG-IN ROD PRESSURE TEST
 4.3.6 DIRECT PLUG-IN - INPUT BLADE ENDURANCE

TRF No. IEC60950_1F

4.5.1, 1.4.12, 1.4.13 HEATING TEST
4.5.5, 4.5 BALL PRESSURE TEST
5.1, ANNEX D TOUCH CURRENT TEST
(SINGLE-PHASE; TN/TT SYSTEM).
5.2.2 ELECTRIC STRENGTH TEST
5.3.1, 5.3.4, 5.3.7 COMPONENT FAILURE TEST
5.3.7 POWER SUPPLY OUTPUT SHORT-
CIRCUIT/OVERLOAD TEST

Summary of compliance with National Differences:

List of countries addressed

- IEC 60950-1:2005 (Second Edition) + Am 1: 2009 + Am 2: 2013
EU Group Differences, EU Special National Conditions, GB, AT, DK, IT, SE, US, CA
- IEC 60950-1:2005 (Second Edition) + Am 1: 2009
DE, KR, SI, FI
- IEC 60950-1:2005 (Second Edition)
AU, CN, IE, NO, ES
- IEC 60950-1:2001 (First Edition)
JP, BY

Explanation of used codes: DE=Germany, DK=Denmark, FI=Finland, GB=United Kingdom, KR=Republic of Korea, SE=Sweden, SI=Slovenia, CA=Canada, CH=Switzerland, ES=Spain, IE=Ireland, IL=Israel, NO=Norway, US=United States of America, AU=Australia, JP=Japan, CN=China, AT=Austria, IT=Italy, BY=Belarus

The product fulfils the requirements of EN 60950-1:2006 + A11:2009 + A1:2010 + A12:2011 + A2:2013

Test item particulars.....:	
Equipment mobility	<input type="checkbox"/> movable <input type="checkbox"/> hand-held <input type="checkbox"/> transportable <input type="checkbox"/> stationary <input type="checkbox"/> for building-in <input checked="" type="checkbox"/> direct plug-in
Connection to the mains	<input checked="" type="checkbox"/> pluggable equipment <input checked="" type="checkbox"/> type A <input type="checkbox"/> type B <input type="checkbox"/> permanent connection <input type="checkbox"/> detachable power supply cord <input type="checkbox"/> non-detachable power supply cord <input type="checkbox"/> not directly connected to the mains
Operating condition.....	<input checked="" type="checkbox"/> continuous <input type="checkbox"/> rated operating / resting time:
Access location	<input checked="" type="checkbox"/> operator accessible <input type="checkbox"/> restricted access location
Over voltage category (OVC)	<input type="checkbox"/> OVC I <input checked="" type="checkbox"/> OVC II <input type="checkbox"/> OVC III <input type="checkbox"/> OVC IV <input type="checkbox"/> other:
Mains supply tolerance (%) or absolute mains supply values.....	-10% of 100, +10% of 240Vac
Tested for IT power systems	<input checked="" type="checkbox"/> Yes <input type="checkbox"/> No
IT testing, phase-phase voltage (V).....	230V for Norway
Class of equipment.....	<input type="checkbox"/> Class I <input checked="" type="checkbox"/> Class II <input type="checkbox"/> Class III <input type="checkbox"/> Not classified
Considered current rating of protective device as part of the building installation (A)	16 (20A for North America)
Pollution degree (PD)	<input type="checkbox"/> PD 1 <input checked="" type="checkbox"/> PD 2 <input type="checkbox"/> PD 3
IP protection class	IPX0
Altitude during operation (m)	2000
Altitude of test laboratory (m)	100
Mass of equipment (kg)	0.058
Possible test case verdicts:	
- test case does not apply to the test object	N/A
- test object does meet the requirement.....	P (Pass)
- test object does not meet the requirement.....	F (Fail)
Testing	
Date of receipt of test item.....	2015-01-08
Date (s) of performance of tests	2014-01-08 to 2015-01-23
General remarks:	
"(See Enclosure #)" refers to additional information appended to the report. "(See appended table)" refers to a table appended to the report.	
Throughout this report a <input type="checkbox"/> comma / <input checked="" type="checkbox"/> point is used as the decimal separator.	
Manufacturer's Declaration per sub-clause 4.2.5 of IEC60950:	
The application for obtaining a CB Test Certificate includes more than one factory location and a declaration from the Manufacturer stating that the sample(s) submitted for evaluation is (are) representative of the products from each factory has been provided.....	<input type="checkbox"/> Yes <input checked="" type="checkbox"/> Not applicable

TRF No. IEC60950_1F

Abbreviations used in the report:

- normal conditions	N.C.	- single fault conditions	S.F.C
- functional insulation	OP	- basic insulation	BI
- double insulation	DI	- supplementary insulation	SI
- between parts of opposite polarity	BOP	- reinforced insulation	RI

Indicate used abbreviations (if any)

IEC 60950-1			
Clause	Requirement + Test	Result - Remark	Verdict
1	GENERAL		P
1.5	Components		P
1.5.1	General	See as below.	P
	Comply with IEC 60950-1 or relevant component standard	(see appended tables 1.5.1)	P
1.5.2	Evaluation and testing of components	<p>Components certified to IEC harmonized standard and checked for correct application.</p> <p>Components not certified are used in accordance with their ratings and they comply with applicable parts of IEC 60950-1 and the relevant component Standard.</p> <p>Components, for which no relevant IEC-Standard exist, have been tested under the conditions occurring in the equipment, using applicable parts of IEC 60950-1.</p>	P
1.5.3	Thermal controls	No thermal controls provided	N/A
1.5.4	Transformers	<p>Transformer used is suitable for the intended application and comply with the relevant requirements of the standard and particularly with those of Annex C.</p> <p>(see appended tables 1.5.1)</p>	P
1.5.5	Interconnecting cables	<p>Interconnecting cables comply with the relevant requirements of this standard..</p> <p>(see appended table 2.1.1.5 c) 1))</p>	P
1.5.6	Capacitors bridging insulation	<p>1) Between lines: min. X2 capacitors according to IEC 60384-14 with 21 days damp heat test.</p> <p>2) Between primary and secondary: Bridged by one or two capacitor(s), which used was certified as Y1 capacitor according to IEC 60384-14 with 21 days damp heat test.</p> <p>Accessible conductive parts separated from other parts by DOUBLE or REINFORCED</p>	P

TRF No. IEC60950_1F

IEC 60950-1			
Clause	Requirement + Test	Result - Remark	Verdict
		INSULATION bridged by CY1 comply with the requirements for LIMITED CURRENT CIRCUITS of clause 2.4 (See appended tables 1.5.1)	
1.5.7	Resistors bridging insulation	See as below	P
1.5.7.1	Resistors bridging functional, basic or supplementary insulation	All resistors are after current fuse (FS1), there are only functional insulation.	P
1.5.7.2	Resistors bridging double or reinforced insulation between a.c. mains and other circuits	No such resistors provided.	N/A
1.5.7.3	Resistors bridging double or reinforced insulation between a.c. mains and antenna or coaxial cable	No such resistors provided.	N/A
1.5.8	Components in equipment for IT power systems	Class II equipment.	N/A
1.5.9	Surge suppressors	See as below.	P
1.5.9.1	General	The VDR (MV1) are in compliance with Annex Q. (See appended table 1.5.1)	P
1.5.9.2	Protection of VDRs	A Current Fuse (FS1) is connected in series with the VDR (MV1) (See appended table 1.5.1)	P
1.5.9.3	Bridging of functional insulation by a VDR	VDR (MV1) were located between Line and Neutral after Current Fuse (FS1) (See appended table 1.5.1)	P
1.5.9.4	Bridging of basic insulation by a VDR	No such VDR provided.	N/A
1.5.9.5	Bridging of supplementary, double or reinforced insulation by a VDR	No such VDR provided.	N/A

1.6	Power interface		P
1.6.1	AC power distribution systems	IT power system for Norway only, TN power system for others.	P
1.6.2	Input current	The steady state input current of the equipment did not exceed the RATED CURRENT by more than 10% under NORMAL LOAD. (See appended table 1.6.2)	P
1.6.3	Voltage limit of hand-held equipment	This appliance is not hand-held equipment	N/A
1.6.4	Neutral conductor	Double or reinforce insulation for rated voltage between	P

TRF No. IEC60950_1F

IEC 60950-1			
Clause	Requirement + Test	Result - Remark	Verdict
1.7.2.6	Ozone	No ozone produces within this equipment.	N/A
1.7.3	Short duty cycles	The equipment is intended for continuous operation	N/A
1.7.4	Supply voltage adjustment	No voltage/frequency setting.	N/A
	Methods and means of adjustment; reference to installation instructions	Same as above.	N/A
1.7.5	Power outlets on the equipment	No socket-outlets provided.	N/A
1.7.6	Fuse identification (marking, special fusing characteristics, cross-reference)	One soldered-in type fuse is provided. Marking adjacent to it states: FS1 T 1.6A/250V	P
1.7.7	Wiring terminals	See as below.	N/A
1.7.7.1	Protective earthing and bonding terminals	Class II equipment.	N/A
1.7.7.2	Terminals for a.c. mains supply conductors	Not permanently connected equipment and no non-detachable power supply cords provided.	N/A
1.7.7.3	Terminals for d.c. mains supply conductors	Mains from AC source only.	N/A
1.7.8	Controls and indicators	No controls and indicators provided.	N/A
1.7.8.1	Identification, location and marking:	Same as above.	N/A
1.7.8.2	Colours	Same as above.	N/A
1.7.8.3	Symbols according to IEC 60417	Same as above.	N/A
1.7.8.4	Markings using figures	Same as above.	N/A
1.7.9	Isolation of multiple power sources	Not multiple power sources provided.	N/A
1.7.10	Thermostats and other regulating devices	No thermostats or similar regulating devices provided.	N/A
1.7.11	Durability	All markings provided on UL Recognized Component labels suitable for surface they are applied upon and meet the durability test and the label was subjected to the permanence of marking test. The label was rubbed with cloth soaked with water for 15 s and then again for 15 s with the cloth soaked with petroleum spirit. After this test there was no damage to the label. The marking on the label did not fade. There was no curling nor	P

TRF No. IEC60950_1F

IEC 60950-1			
Clause	Requirement + Test	Result - Remark	Verdict
		lifting of the label edge.	
1.7.12	Removable parts	No marking placed on removable parts.	P
1.7.13	Replaceable batteries	No battery provided.	N/A
	Language(s)	Same as above.	---
1.7.14	Equipment for restricted access locations.....	Equipment is not intended for use in restricted access locations.	N/A

2	PROTECTION FROM HAZARDS		P
2.1	Protection from electric shock and energy hazards		P
2.1.1	Protection in operator access areas	See as below.	P
2.1.1.1	Access to energized parts	No operator access to energized parts.	P
	Test by inspection	No operator access to energized parts.	P
	Test with test finger (Figure 2A)	The test finger was unable to contact bare hazardous parts, basic insulation, or ELV circuits.	P
	Test with test pin (Figure 2B)	The test pin was unable to contact bare hazardous parts.	P
	Test with test probe (Figure 2C)	No TNV circuits provided.	N/A
2.1.1.2	Battery compartments	No battery compartments provided.	N/A
2.1.1.3	Access to ELV wiring	No ELV wiring in operator accessible area.	N/A
	Working voltage (V_{peak} or V_{rms}); minimum distance through insulation (mm)	Same as above.	---
2.1.1.4	Access to hazardous voltage circuit wiring	No hazardous voltage wiring in operator accessible area.	N/A
2.1.1.5	Energy hazards	The hazardous energy circuits can't be bridged by the test finger in a straight position. (see appended table 2.1.1.5 c 1))	P
2.1.1.6	Manual controls	No manual controls provided.	N/A
2.1.1.7	Discharge of capacitors in equipment	X-Capacitor (CX1) provided was 0.1 μ F.	N/A
	Measured voltage (V); time-constant (s).....	Same as above.	---
2.1.1.8	Energy hazards – d.c. mains supply	Mains from AC source only.	N/A
	a) Capacitor connected to the d.c. mains supply ...	Same as above.	N/A

TRF No. IEC60950_1F

IEC 60950-1			
Clause	Requirement + Test	Result - Remark	Verdict
	b) Internal battery connected to the d.c. mains supply	Same as above.	N/A
2.1.1.9	Audio amplifiers	No audio amplifiers provided.	N/A
2.1.2	Protection in service access areas	No serviceable unit. This unit is not intended to service in the event of failure. Service personnel will replace the unit.	N/A
2.1.3	Protection in restricted access locations	The equipment is not intended to be used in restricted locations.	N/A

2.2	SELV circuits		P
2.2.1	General requirements	(see appended table 2.2)	P
2.2.2	Voltages under normal conditions (V)	All accessible voltages are less than 42.4 Vp or 60 V dc and are classified as SELV (see appended table 2.2)	P
2.2.3	Voltages under fault conditions (V)	Under fault conditions voltages never exceed 71V peak and 120V dc and do not exceed 42.4V peak or 60V dc for more than 0.2 sec. (see appended table 2.2)	P
2.2.4	Connection of SELV circuits to other circuits	SELV circuit are only connected to other SELV circuits or limited current circuits.	P

2.3	TNV circuits		N/A
2.3.1	Limits	No TNV circuits provided.	N/A
	Type of TNV circuits	Same as above.	---
2.3.2	Separation from other circuits and from accessible parts	Same as above.	N/A
2.3.2.1	General requirements	Same as above.	N/A
2.3.2.2	Protection by basic insulation	Same as above.	N/A
2.3.2.3	Protection by earthing	Same as above.	N/A
2.3.2.4	Protection by other constructions	Same as above.	N/A
2.3.3	Separation from hazardous voltages	Same as above.	N/A
	Insulation employed	Same as above.	---
2.3.4	Connection of TNV circuits to other circuits	Same as above.	N/A

TRF No. IEC60950_1F

IEC 60950-1			
Clause	Requirement + Test	Result - Remark	Verdict

	Insulation employed	Same as above.	---
2.3.5	Test for operating voltages generated externally	Same as above.	N/A

2.4	Limited current circuits		P
2.4.1	General requirements	Worst case selected: Model No. 6A-181WP05 For bridging capacitor CY1 with 1000pF. Used measuring instrument of Figure D.1, the voltage, U_2 is measured and the current is calculated by dividing the measured voltage, U_2 by 500. The calculated value shall not exceed 0.7mA peak.	P
2.4.2	Limit values	0.7mA	P
	Frequency (Hz).....	--	---
	Measured current (mA)	0.184mA	---
	Measured voltage (V).....	92mV	---
	Measured circuit capacitance (nF or μ F).....	$\leq 0.1\mu$ F for parts not exceeding 450V peak or d.c.	---
2.4.3	Connection of limited current circuits to other circuits	SELV circuit are only connected to other SELV circuits or limited current circuits.	P

2.5	Limited power sources		P
	a) Inherently limited output	No Inherently limited output.	N/A
	b) Impedance limited output	No impedance limited output.	N/A
	c) Regulating network or IC current limiter, limits output under normal operating and single fault condition	(see appended table 2.5)	P
	Use of integrated circuit (IC) current limiters	No IC current limiter provided.	N/A
	d) Overcurrent protective device limited output	No Overcurrent protective device provided.	N/A
	Max. output voltage (V), max. output current (A), max. apparent power (VA)	(see appended table 2.5)	---
	Current rating of overcurrent protective device (A)	No Overcurrent protective device provided.	---

2.6	Provisions for earthing and bonding		N/A
-----	-------------------------------------	--	-----

TRF No. IEC60950_1F

IEC 60950-1			
Clause	Requirement + Test	Result - Remark	Verdict
2.6.1	Protective earthing	Class II equipment.	N/A
2.6.2	Functional earthing	Same as above.	N/A
	Use of symbol for functional earthing.....:	Same as above.	N/A
2.6.3	Protective earthing and protective bonding conductors	Same as above.	N/A
2.6.3.1	General	Same as above.	N/A
2.6.3.2	Size of protective earthing conductors	Same as above.	N/A
	Rated current (A), cross-sectional area (mm ²), AWG.....:	Same as above.	---
2.6.3.3	Size of protective bonding conductors	Same as above.	N/A
	Rated current (A), cross-sectional area (mm ²), AWG.....:	Same as above.	---
	Protective current rating (A), cross-sectional area (mm ²), AWG.....:	Same as above.	---
2.6.3.4	Resistance of earthing conductors and their terminations; resistance (Ω), voltage drop (V), test current (A), duration (min).....:	Same as above.	N/A
2.6.3.5	Colour of insulation.....:	Same as above.	N/A
2.6.4	Terminals	Same as above.	N/A
2.6.4.1	General	Same as above.	N/A
2.6.4.2	Protective earthing and bonding terminals	Same as above.	N/A
	Rated current (A), type, nominal thread diameter (mm).....:	Same as above.	---
2.6.4.3	Separation of the protective earthing conductor from protective bonding conductors	Same as above.	N/A
2.6.5	Integrity of protective earthing	Same as above.	N/A
2.6.5.1	Interconnection of equipment	Same as above.	N/A
2.6.5.2	Components in protective earthing conductors and protective bonding conductors	Same as above.	N/A
2.6.5.3	Disconnection of protective earth	Same as above.	N/A
2.6.5.4	Parts that can be removed by an operator	Same as above.	N/A
2.6.5.5	Parts removed during servicing	Same as above.	N/A
2.6.5.6	Corrosion resistance	Same as above.	N/A
2.6.5.7	Screws for protective bonding	Same as above.	N/A
2.6.5.8	Reliance on telecommunication network or cable distribution system	Same as above.	N/A
2.7	Overcurrent and earth fault protection in primary circuits		P

TRF No. IEC60950_1F

IEC 60950-1			
Clause	Requirement + Test	Result - Remark	Verdict
2.7.1	Basic requirements	Protective devices are integrated in the equipment.	P
	Instructions when protection relies on building installation	The equipment is pluggable Type A.	N/A
2.7.2	Faults not simulated in 5.3.7	Adequate fault protection provided.	P
2.7.3	Short-circuit backup protection	Pluggable Type A, protective devices are integrated in the equipment.	P
2.7.4	Number and location of protective devices	Over current protection by one Current Fuse.	P
2.7.5	Protection by several devices	Over current protection by one Current Fuse.	N/A
2.7.6	Warning to service personnel.....	No service work necessary.	N/A
2.8	Safety interlocks		N/A
2.8.1	General principles	No safety interlocks provided.	N/A
2.8.2	Protection requirements	Same as above.	N/A
2.8.3	Inadvertent reactivation	Same as above.	N/A
2.8.4	Fail-safe operation	Same as above.	N/A
	Protection against extreme hazard	Same as above.	N/A
2.8.5	Moving parts	Same as above.	N/A
2.8.6	Overriding	Same as above.	N/A
2.8.7	Switches, relays and their related circuits	Same as above.	N/A
2.8.7.1	Separation distances for contact gaps and their related circuits (mm)	Same as above.	N/A
2.8.7.2	Overload test	Same as above.	N/A
2.8.7.3	Endurance test	Same as above.	N/A
2.8.7.4	Electric strength test	Same as above.	N/A
2.8.8	Mechanical actuators	Same as above.	N/A
2.9	Electrical insulation		P
2.9.1	Properties of insulating materials	Electrical insulation does not rely upon driving belts or couplings. Natural rubber materials containing asbestos and hygroscopic materials are not used as insulation. Adequate clearances and creepage distances.	P

TRF No. IEC60950_1F

IEC 60950-1			
Clause	Requirement + Test	Result - Remark	Verdict
2.9.2	Humidity conditioning	Humidity treatment performed to 120hrs in condition: 95% humidity, 40°C. Electric strength test conducted after the humidity treatment.	P
	Relative humidity (%), temperature (°C)	93%, 40°C	---
2.9.3	Grade of insulation	No breakdown of insulation. See 5.2	P
2.9.4	Separation from hazardous voltages	See as below.	P
	Method(s) used	Method 1 used.	---

2.10	Clearances, creepage distances and distances through insulation		P
2.10.1	General	See as below.	P
2.10.1.1	Frequency	The frequency does not exceeding 30 kHz.	P
2.10.1.2	Pollution degrees	Pollution degree 2 applicable	P
2.10.1.3	Reduced values for functional insulation	See sub-clause 5.3.4.	P
2.10.1.4	Intervening unconnected conductive parts	No such conductive parts.	N/A
2.10.1.5	Insulation with varying dimensions	Not applicable.	N/A
2.10.1.6	Special separation requirements	No TNV circuit provided.	N/A
2.10.1.7	Insulation in circuits generating starting pulses	No lamps provided.	N/A
2.10.2	Determination of working voltage	See as below.	P
2.10.2.1	General	The rms and the peak voltage were measured on the switching power supply. (See appended table 2.10.2)	P
2.10.2.2	RMS working voltage	(See appended table 2.10.2)	P
2.10.2.3	Peak working voltage	(See appended table 2.10.2)	P
2.10.3	Clearances	(See appended table 2.10.3 and 2.10.4).	P
2.10.3.1	General	Annex F and minimum clearances considered.	P
2.10.3.2	Mains transient voltages	See as below.	P
	a) AC mains supply	Overvoltage category II for primary circuit and transient voltage 2500V _{peak} .	P
	b) Earthed d.c. mains supplies	Not applicable.	N/A
	c) Unearthed d.c. mains supplies	Not applicable.	N/A
	d) Battery operation	Not applicable.	N/A

TRF No. IEC60950_1F

IEC 60950-1			
Clause	Requirement + Test	Result - Remark	Verdict
2.10.3.3	Clearances in primary circuits	(see appended table 2.10.3 and 2.10.4)	P
2.10.3.4	Clearances in secondary circuits	See sub-clause 5.3.4.	N/A
2.10.3.5	Clearances in circuits having starting pulses	No lamps provided.	N/A
2.10.3.6	Transients from a.c. mains supply	Overvoltage category II for secondary circuit and transient voltage 1500Vpeak.	P
2.10.3.7	Transients from d.c. mains supply	Mains from AC source only.	N/A
2.10.3.8	Transients from telecommunication networks and cable distribution systems	No networks and cable distribution systems provided.	N/A
2.10.3.9	Measurement of transient voltage levels	See sub-clause 2.10.3.6.	N/A
	a) Transients from a mains supply	Same as above.	N/A
	For an a.c. mains supply	Same as above.	N/A
	For a d.c. mains supply	Same as above.	N/A
	b) Transients from a telecommunication network :	Same as above.	N/A
2.10.4	Creepage distances	See as below.	P
2.10.4.1	General	(see appended table 2.10.3 and 2.10.4)	P
2.10.4.2	Material group and comparative tracking index	See as below.	P
	CTI tests	CTI rating for all materials of min. 100.	—
2.10.4.3	Minimum creepage distances	(see appended table 2.10.3 and 2.10.4)	P
2.10.5	Solid insulation	Solid or laminated insulating materials having adequate thickness are provided.	P
2.10.5.1	General	See as below.	P
2.10.5.2	Distances through insulation	(see appended table 2.10.5)	P
2.10.5.3	Insulating compound as solid insulation	Certified sources of photo couplers used. See 2.10.5.2 and 2.10.10	P
2.10.5.4	Semiconductor devices	See 2.10.5.3.	P
2.10.5.5	Cemented joints	Not applicable.	N/A
2.10.5.6	Thin sheet material – General	Complied check.	P
2.10.5.7	Separable thin sheet material	Reinforced insulation.	P
	Number of layers (pcs)	Two layers used, each of which complies with the required electric strength test (see appended table 2.10.5)	—
2.10.5.8	Non-separable thin sheet material	No Non-separable thin sheet	N/A

TRF No. IEC60950_1F

IEC 60950-1			
Clause	Requirement + Test	Result - Remark	Verdict
		material employed.	
2.10.5.9	Thin sheet material – standard test procedure	Not applicable.	N/A
	Electric strength test	Same as above.	---
2.10.5.10	Thin sheet material – alternative test procedure	See as below.	P
	Electric strength test	(See appended table 2.10.5)	---
2.10.5.11	Insulation in wound components	See sub-clause 2.10.5.12.	P
2.10.5.12	Wire in wound components	Certified source of triple insulated wire used in T1 for Reinforced insulation.	P
	Working voltage	See 2.10.2.	P
	a) Basic insulation not under stress	Not applicable.	N/A
	b) Basic, supplementary, reinforced insulation	Not applicable.	N/A
	c) Compliance with Annex U	(See annex U and appended table 1.5.1.)	P
	Two wires in contact inside wound component; angle between 45° and 90°	Insulation tape and/or tubing provided.	---
2.10.5.13	Wire with solvent-based enamel in wound components	Not applicable.	N/A
	Electric strength test	Same as above.	---
	Routine test	Same as above.	N/A
2.10.5.14	Additional insulation in wound components	Not applicable.	N/A
	Working voltage	Same as above.	N/A
	- Basic insulation not under stress	Same as above.	N/A
	- Supplementary, reinforced insulation	Same as above.	N/A
2.10.6	Construction of printed boards	See as below.	P
2.10.6.1	Uncoated printed boards	(see appended table 2.10.3 and 2.10.4)	P
2.10.6.2	Coated printed boards	No coated printed board provided.	N/A
2.10.6.3	Insulation between conductors on the same inner surface of a printed board	Not applicable.	N/A
2.10.6.4	Insulation between conductors on different layers of a printed board	Not applicable.	N/A
	Distance through insulation	Same as above.	N/A
	Number of insulation layers (pcs).....	Same as above.	N/A
2.10.7	Component external terminations	Not applicable.	N/A
2.10.8	Tests on coated printed boards and coated components	Not applicable.	N/A

TRF No. IEC60950_1F

IEC 60950-1			
Clause	Requirement + Test	Result - Remark	Verdict
2.10.8.1	Sample preparation and preliminary inspection	Same as above.	N/A
2.10.8.2	Thermal conditioning	Same as above.	N/A
2.10.8.3	Electric strength test	Same as above.	N/A
2.10.8.4	Abrasion resistance test	Same as above.	N/A
2.10.9	Thermal cycling	Not applicable.	N/A
2.10.10	Test for Pollution Degree 1 environment and insulating compound	Not applicable.	N/A
2.10.11	Tests for semiconductor devices and cemented joints	Not applicable.	N/A
2.10.12	Enclosed and sealed parts	Not applicable.	N/A

3	WIRING, CONNECTIONS AND SUPPLY		P
3.1	General		P
3.1.1	Current rating and overcurrent protection	All internal wiring used in the distribution of secondary protected against overcurrent and short circuit by suitably rated protective devices.	P
3.1.2	Protection against mechanical damage	The wires are routed away from sharp edges and parts which could damage insulation.	P
3.1.3	Securing of internal wiring	The wires are positioned in such a manner that prevents excessive strain, loosening of terminal connections and damage of conductor insulation.	P
3.1.4	Insulation of conductors	Uninsulated conductors have been adequately fixed to prevent, in normal use, any reduction of creepage or clearance distances below those prescribed by in 2.9.	P
3.1.5	Beads and ceramic insulators	The equipment does not have any beads or similar insulators.	N/A
3.1.6	Screws for electrical contact pressure	No screws electrical connection used.	N/A
3.1.7	Insulating materials in electrical connections	No contact pressure through insulating material.	N/A
3.1.8	Self-tapping and spaced thread screws	No spaced threads screws for electrical connections.	N/A
3.1.9	Termination of conductors	All conductors are reliable secured.	P

TRF No. IEC60950_1F

IEC 60950-1			
Clause	Requirement + Test	Result - Remark	Verdict

	10 N pull test	10 N pull test performed for all relevant conductors. No hazards caused hereby.	—
3.1.10	Sleeving on wiring	No Sleeving provided.	N/A

3.2	Connection to a mains supply		P
3.2.1	Means of connection	See as below	P
3.2.1.1	Connection to an a.c. mains supply	The unit is provided with a means for direct plug-in.	P
3.2.1.2	Connection to a d.c. mains supply	Mains from AC source only.	N/A
3.2.2	Multiple supply connections	Not multiple power sources provided.	N/A
3.2.3	Permanently connected equipment	The equipment is not permanently connected.	N/A
	Number of conductors, diameter of cable and conduits (mm)	Same as above.	—
3.2.4	Appliance inlets	Direct plug-in equipment	N/A
3.2.5	Power supply cords	Direct plug-in equipment	N/A
3.2.5.1	AC power supply cords	Same as above.	N/A
	Type	Same as above.	—
	Rated current (A), cross-sectional area (mm ²), AWG	Same as above.	—
3.2.5.2	DC power supply cords	Mains from AC source only.	N/A
3.2.6	Cord anchorages and strain relief	The equipment does not use a non-detachable power supply cord.	N/A
	Mass of equipment (kg), pull (N)	Same as above.	—
	Longitudinal displacement (mm)	Same as above.	—
3.2.7	Protection against mechanical damage	Direct plug-in equipment	N/A
3.2.8	Cord guards	Direct plug-in equipment	N/A
	Diameter or minor dimension D (mm); test mass (g)	Same as above.	—
	Radius of curvature of cord (mm).....	Same as above.	—
3.2.9	Supply wiring space	Direct plug-in equipment	N/A

3.3	Wiring terminals for connection of external conductors		N/A
3.3.1	Wiring terminals	The equipment is not permanently connected of provided with a non-detachable	N/A

TRF No. IEC60950_1F

IEC 60950-1			
Clause	Requirement + Test	Result - Remark	Verdict
		power supply cord.	
3.3.2	Connection of non-detachable power supply cords	Same as above.	N/A
3.3.3	Screw terminals	Same as above.	N/A
3.3.4	Conductor sizes to be connected	Same as above.	N/A
	Rated current (A), cord/cable type, cross-sectional area (mm ²).....:	Same as above.	---
3.3.5	Wiring terminal sizes	Same as above.	N/A
	Rated current (A), type, nominal thread diameter (mm)	Same as above.	---
3.3.6	Wiring terminal design	Same as above.	N/A
3.3.7	Grouping of wiring terminals	Same as above.	N/A
3.3.8	Stranded wire	Same as above.	N/A

3.4	Disconnection from the mains supply		P
3.4.1	General requirement	See as below.	P
3.4.2	Disconnect devices	The plug of direct plug-in is considered to be the disconnect device.	P
3.4.3	Permanently connected equipment	The unit is not permanently connected equipment.	N/A
3.4.4	Parts which remain energized	No parts remained energy after disconnection of plug.	P
3.4.5	Switches in flexible cords	No such switch provided.	N/A
3.4.6	Number of poles - single-phase and d.c. equipment	Disconnect device disconnects both poles simultaneously.	P
3.4.7	Number of poles - three-phase equipment	Single-phase equipment.	N/A
3.4.8	Switches as disconnect devices	No switch or the switch is not a disconnect device.	N/A
3.4.9	Plugs as disconnect devices	The plug of direct plug-in is considered to be the disconnect device.	P
3.4.10	Interconnected equipment	Not interconnected equipment.	N/A
3.4.11	Multiple power sources	Not multiple power sources provided.	N/A

3.5	Interconnection of equipment		P
3.5.1	General requirements	See as below.	P
3.5.2	Types of interconnection circuits	Interconnection circuits of SELV or LCC through secondary connector.	P

TRF No. IEC60950_1F

IEC 60950-1			
Clause	Requirement + Test	Result - Remark	Verdict

3.5.3	ELV circuits as interconnection circuits	No ELV interconnection.	N/A
3.5.4	Data ports for additional equipment	Not applicable.	N/A

4	PHYSICAL REQUIREMENTS		P
4.1	Stability		N/A
	Angle of 10°	Direct plug in equipment.	N/A
	Test force (N)	Equipment is not a floor standing unit.	N/A

4.2	Mechanical strength		P
4.2.1	General	See as below.	P
	Rack-mounted equipment.	Not Rack-mounted equipment.	N/A
4.2.2	Steady force test, 10 N	10 N were applied to components. No energy or other hazards.	P
4.2.3	Steady force test, 30 N	No internal enclosure provided.	N/A
4.2.4	Steady force test, 250 N	250N force applied to chassis shape for following area: No energy or other hazards as below location: 1) Top 2) Side 3) Bottom Material used: (see appended tables 1.5.1)	P
4.2.5	Impact test	Direct plug in equipment	N/A
	Fall test	Same as above.	N/A
	Swing test	Same as above.	N/A
4.2.6	Drop test; height (mm)	No energy or other hazards as below location: 1) Top 2) Side 3) Bottom Material used: (see appended tables 1.5.1)	P
4.2.7	Stress relief test	No indication of shrinkage or distortion on enclosures due to the stress relief test 79.5°C/7h. Material used: (see appended tables 1.5.1)	P

TRF No. IEC60950_1F

IEC 60950-1			
Clause	Requirement + Test	Result - Remark	Verdict
4.2.8	Cathode ray tubes	No cathode ray tube provided.	N/A
	Picture tube separately certified	Same as above	
4.2.9	High pressure lamps	No high pressure lamps provided.	N/A
4.2.10	Wall or ceiling mounted equipment; force (N)	Not Wall or ceiling mounted equipment.	N/A

4.3	Design and construction		P
4.3.1	Edges and corners	All edges and corners are judged to be sufficiently well rounded so as not to constitute a hazard.	P
4.3.2	Handles and manual controls; force (N).....	No handles or manual controls provided.	N/A
4.3.3	Adjustable controls	No control devices provided.	N/A
4.3.4	Securing of parts	All components are fixed to retain position in event of termination failure.	P
4.3.5	Connection by plugs and sockets	No misconnection to mains is likely for output (SELV) connector. Connectors complying with IEC 60083 or IEC 60320-1 is not be used for SELV circuit output.	N/A
4.3.6	Direct plug-in equipment	1) <u>US plug</u> : The dimension complied with the requirement of ANSI/NEMA WD6 and testing complied with UL1310 as below a) Weight and Moment test: Result: W=81.96.0g ($\leq 794g$) S=21.36mm X=20.83mm Y=16.88mm Z=16.71mm WY/Z=82.79g ($\leq 1361g$) WY/S=64.77g ($\leq 1361g$) WX=1707.2gm ($\leq 57104gm$) b) Blade securement test Result: Blade 1: 0.01mm Blade 2: 0.01mm Blade 1 and 2: 0.01mm The blades did not loosen by more than 2.4 mm or pull out All testing repeat two times	P

TRF No. IEC60950_1F

IEC 60950-1			
Clause	Requirement + Test	Result - Remark	Verdict
		<p>c) Security of Input contacts Result: Blade 1: 0.01mm Blade 2: 0.01mm Both Blades: 0.01mm The blades did not loosen to a degree that would introduce a risk of a fire or an electric shock All testing repeat two times</p> <p>d) Resistance to crushing Result: There was no splitting, cracking or shattering of the enclosure that would expose internal wiring or hazardous live parts</p> <p>e) Rod pressure: Result: The equipment was connected to 264Vac, 60Hz, during this test, peak voltage and touch current were monitored between earth ground and all parts of the enclosure (the outer foil wrap). Following the test, the sample was subjected to the Electric Strength Test. Max. voltage=3.84Vpk</p> <p>f) The perimeter of the face section from which the blades project do not less than 7.9 mm from any point on either blade</p> <p>g) The replaceable plug modules were repeat for 6000 cycles with the unit de-energized. Input plug holder (near blade=60.8°C (before cycling); 62.4°C (after cycling); Ambient air=24.9°C (before cycling); 26.4°C (after cycling)</p> <p>Electric Strength tests performed after all tests as above. (see appended table 5.2)</p> <p>2) <u>EU plug</u>: The main plug has been evaluated according to</p>	

TRF No. IEC60950_1F

IEC 60950-1			
Clause	Requirement + Test	Result - Remark	Verdict
		<p>EN50075, Report No. TP-15012 (150200245TWN-001)</p> <p>3) <u>AU plug</u>: The main plug has been evaluated according to AS/NZS 3112: 2011 + A1: 2012 + A2: 2013, Report No.: TP-14032 (TW14040234 and TW14040234(R1))</p> <p>4) <u>UK plug</u>: The main plug has been evaluated according to BS 1361-1: 1995 + A1: 1997 + A2: 2003+ A3: 2007+ A4: 2012, Report No. TP-12069 (TP12100075-ETS)</p> <p>5) <u>CN plug</u>: The plug have to be checked during national approval.</p> <p>6) <u>KR plug</u>: The plug have to be checked during national approval.</p>	
	Torque	<p>1) US plug: 0.044 Nm.</p> <p>2) CN plug: 0.044 Nm.</p> <p>3) EU plug: 0.065 Nm.</p> <p>4) KR plug: 0.065 Nm.</p> <p>5) AU plug: 0.05 Nm.</p> <p>6) UK plug: 0.047 Nm.</p>	
	Compliance with the relevant mains plug standard	The requirements have to be checked during national approval.	N/A
4.3.7	Heating elements in earthed equipment	No heating elements provided.	N/A
4.3.8	Batteries	No batteries provided.	N/A
	- Overcharging of a rechargeable battery	Same as above.	N/A
	- Unintentional charging of a non-rechargeable battery	Same as above.	N/A
	- Reverse charging of a rechargeable battery	Same as above.	N/A
	- Excessive discharging rate for any battery	Same as above.	N/A
4.3.9	Oil and grease	No oil or grease provided.	N/A
4.3.10	Dust, powders, liquids and gases	Equipment in intended use not considered to be exposed to	N/A

TRF No. IEC60950_1F

IEC 60950-1			
Clause	Requirement + Test	Result - Remark	Verdict
		these.	
4.3.11	Containers for liquids or gases	The equipment does not contain liquid.	N/A
4.3.12	Flammable liquids	No flammable liquids in this unit.	N/A
	Quantity of liquid (l)	Same as above.	---
	Flash point (°C)	Same as above.	---
4.3.13	Radiation		N/A
4.3.13.1	General	See as below.	N/A
4.3.13.2	Ionizing radiation	No ionizing radiation provided.	N/A
	Measured radiation (pA/kg)	Same as above.	---
	Measured high-voltage (kV)	Same as above.	---
	Measured focus voltage (kV)	Same as above.	---
	CRT markings	Same as above.	---
4.3.13.3	Effect of ultraviolet (UV) radiation on materials	No UV radiation provided.	N/A
	Part, property, retention after test, flammability classification	Same as above.	N/A
4.3.13.4	Human exposure to ultraviolet (UV) radiation	No UV radiation provided.	N/A
4.3.13.5	Lasers (including laser diodes) and LEDs	No Lasers (including laser diodes) and LEDs provided.	N/A
4.3.13.5.1	Lasers (including laser diodes)	No lasers provided.	N/A
	Laser class	Same as above.	---
4.3.13.5.2	Light emitting diodes (LEDs)	No Light emitting diodes (LEDs) provided.	N/A
4.3.13.6	Other types	No other types provided.	N/A

4.4	Protection against hazardous moving parts		N/A
4.4.1	General	No moving parts provided.	N/A
4.4.2	Protection in operator access areas	Same as above.	N/A
	Household and home/office document/media shredders	Same as above.	N/A
4.4.3	Protection in restricted access locations	Same as above.	N/A
4.4.4	Protection in service access areas	Same as above.	N/A
4.4.5	Protection against moving fan blades	Same as above.	N/A
4.4.5.1	General	Same as above.	N/A
	Not considered to cause pain or injury. a).....	Same as above.	N/A
	Is considered to cause pain, not injury. b)	Same as above.	N/A

TRF No. IEC60950_1F

IEC 60950-1			
Clause	Requirement + Test	Result - Remark	Verdict
	Considered to cause injury. c)	Same as above.	N/A
4.4.5.2	Protection for users	Same as above.	N/A
	Use of symbol or warning	Same as above.	N/A
4.4.5.3	Protection for service persons	Same as above.	N/A
	Use of symbol or warning	Same as above.	N/A

4.5	Thermal requirements	P
4.5.1	General	See as below.
4.5.2	Temperature tests	(see appended table 4.5)
	Normal load condition per Annex L	Operated in the most unfavourable way of operation given in the operating instructions until steady conditions established.
4.5.3	Temperature limits for materials	(see appended table 4.5)
4.5.4	Touch temperature limits	(see appended table 4.5)
4.5.5	Resistance to abnormal heat	Phenolic bobbin material used in T1, which are acceptable without test as below. 1) Chang Chun Type T375J 2) Sumitomo Type PM-9820 Other material for plug holder as below: 1) SABIC type SE1X (see appended table 4.5.5)

4.6	Openings in enclosures	P
4.6.1	Top and side openings	No opening provided.
	Dimensions (mm)	Same as above.
4.6.2	Bottoms of fire enclosures	No opening provided.
	Construction of the bottom, dimensions (mm) ...	Same as above.
4.6.3	Doors or covers in fire enclosures	No such doors or covers
4.6.4	Openings in transportable equipment	Direct plug-in equipment
4.6.4.1	Constructional design measures	Same as above.
	Dimensions (mm)	Same as above.
4.6.4.2	Evaluation measures for larger openings	Same as above.
4.6.4.3	Use of metallized parts	Same as above.

TRF No. IEC60950_1F

IEC 60950-1			
Clause	Requirement + Test	Result - Remark	Verdict
4.6.5	Adhesives for constructional purposes	No barrier or screen secured with adhesive.	N/A
	Conditioning temperature (°C), time (weeks).....:	Same as above.	

4.7	Resistance to fire		P
4.7.1	Reducing the risk of ignition and spread of flame	Method 1: Selection and application of components and materials which minimize the possibility of ignition and spread of flame.	P
	Method 1, selection and application of components wiring and materials	(see appended table 4.7)	P
	Method 2, application of all of simulated fault condition tests	Not applicable.	N/A
4.7.2	Conditions for a fire enclosure	See as below	P
4.7.2.1	Parts requiring a fire enclosure	Fire enclosure covers all parts.	P
4.7.2.2	Parts not requiring a fire enclosure	See 4.7.2.1.	N/A
4.7.3	Materials		P
4.7.3.1	General	Materials with the required flammability classes are used.	P
4.7.3.2	Materials for fire enclosures	Flammability rating minimum V-1. (see appended table 1.5.1)	P
4.7.3.3	Materials for components and other parts outside fire enclosures	No components or parts outside fire enclosures.	N/A
4.7.3.4	Materials for components and other parts inside fire enclosures	All internal materials are rated minimum 94V-2 or better or are mounted on a PWB rated 94V-1 or better.	P
4.7.3.5	Materials for air filter assemblies	No air filter assemblies.	N/A
4.7.3.6	Materials used in high-voltage components	No high voltage component used.	N/A

5	ELECTRICAL REQUIREMENTS AND SIMULATED ABNORMAL CONDITIONS		P
5.1	Touch current and protective conductor current		P
5.1.1	General	(see appended Table 5.1)	P
5.1.2	Configuration of equipment under test (EUT)	See as below.	P
5.1.2.1	Single connection to an a.c. mains supply	EUT has only one mains connections.	P
5.1.2.2	Redundant multiple connections to an a.c. mains supply	See 5.1.2.1.	N/A

TRF No. IEC60950_1F

IEC 60950-1			
Clause	Requirement + Test	Result - Remark	Verdict
5.1.2.3	Simultaneous multiple connections to an a.c. mains supply	See 5.1.2.1	N/A
5.1.3	Test circuit	Equipment of figure 5A used.	P
5.1.4	Application of measuring instrument	Tests are conducted using one of the measuring instruments in annex D, or any other circuit giving the same results.	P
5.1.5	Test procedure	The touch current was measured to output connector and enclosure with foil.	P
5.1.6	Test measurements	See as below.	P
	Supply voltage (V)	(See appended table 5.1)	—
	Measured touch current (mA)	(See appended table 5.1)	—
	Max. allowed touch current (mA)	(See appended table 5.1)	—
	Measured protective conductor current (mA)	N/A	—
	Max. allowed protective conductor current (mA)...	N/A	—
5.1.7	Equipment with touch current exceeding 3.5 mA	Touch current does not exceed 3.5mA	N/A
5.1.7.1	General	Same as above.	N/A
5.1.7.2	Simultaneous multiple connections to the supply	Same as above.	N/A
5.1.8	Touch currents to telecommunication networks and cable distribution systems and from telecommunication networks	No TNV circuit provided.	N/A
5.1.8.1	Limitation of the touch current to a telecommunication network or to a cable distribution system	Same as above.	N/A
	Supply voltage (V)	Same as above.	—
	Measured touch current (mA)	Same as above.	—
	Max. allowed touch current (mA)	Same as above.	—
5.1.8.2	Summation of touch currents from telecommunication networks	Same as above.	N/A
	a) EUT with earthed telecommunication ports	Same as above.	N/A
	b) EUT whose telecommunication ports have no reference to protective earth	Same as above.	N/A
5.2	Electric strength		P
5.2.1	General	Based on the electric strength test the use of the insulating materials within the equipment is satisfactory.	P

TRF No. IEC60950_1F

IEC 60950-1			
Clause	Requirement + Test	Result - Remark	Verdict

		(see appended table 5.2)	
5.2.2	Test procedure	No insulation breakdown detected during the test (see appended table 5.2)	P

5.3	Abnormal operating and fault conditions		P
5.3.1	Protection against overload and abnormal operation	(see appended table 5.3)	P
5.3.2	Motors	No motors provided.	N/A
5.3.3	Transformers	(see appended Annex C)	P
5.3.4	Functional insulation.....:	Functional insulation complies with the requirements c).	P
5.3.5	Electromechanical components	No electromechanical components.	N/A
5.3.6	Audio amplifiers in ITE	No audio amplifiers provided.	N/A
5.3.7	Simulation of faults	(see appended table 5.3)	P
5.3.8	Unattended equipment	None of them are used.	N/A
5.3.9	Compliance criteria for abnormal operating and fault conditions	No fire, emission of molten metal or deformation was noted during the tests.	P
5.3.9.1	During the tests	Neither fire burns the equipment or molten metal.	P
5.3.9.2	After the tests	Electric strength test made.	P

6	CONNECTION TO TELECOMMUNICATION NETWORKS		N/A
6.1	Protection of telecommunication network service persons, and users of other equipment connected to the network, from hazards in the equipment		N/A
6.1.1	Protection from hazardous voltages		N/A
6.1.2	Separation of the telecommunication network from earth		N/A
6.1.2.1	Requirements	No TNV circuit provided.	N/A
	Supply voltage (V)	Same as above.	---
	Current in the test circuit (mA)	Same as above.	---
6.1.2.2	Exclusions	Same as above.	N/A

6.2	Protection of equipment users from overvoltages on telecommunication networks		N/A
6.2.1	Separation requirements	No TNV circuit provided.	N/A
6.2.2	Electric strength test procedure	Same as above.	N/A

TRF No. IEC60950_1F

IEC 60950-1			
Clause	Requirement + Test	Result - Remark	Verdict

6.2.2.1	Impulse test	Same as above.	N/A
6.2.2.2	Steady-state test	Same as above.	N/A
6.2.2.3	Compliance criteria	Same as above.	N/A

6.3	Protection of the telecommunication wiring system from overheating		N/A
	Max. output current (A)	No TNV circuit provided.	---
	Current limiting method	Same as above.	---

7	CONNECTION TO CABLE DISTRIBUTION SYSTEMS		N/A
7.1	General	No cable distribution systems	N/A
7.2	Protection of cable distribution system service persons, and users of other equipment connected to the system, from hazardous voltages in the equipment	Same as above.	N/A
7.3	Protection of equipment users from overvoltages on the cable distribution system	Same as above.	N/A
7.4	Insulation between primary circuits and cable distribution systems	Same as above.	N/A
7.4.1	General	Same as above.	N/A
7.4.2	Voltage surge test	Same as above.	N/A
7.4.3	Impulse test	Same as above.	N/A

IEC 60950-1			
Clause	Requirement + Test	Result - Remark	Verdict
A	ANNEX A, TESTS FOR RESISTANCE TO HEAT AND FIRE		N/A
A.1	Flammability test for fire enclosures of movable equipment having a total mass exceeding 18 kg, and of stationary equipment (see 4.7.3.2)	Unit total mass not exceeding 18 kg.	N/A
A.1.1	Samples.....	Same as above.	---
	Wall thickness (mm).....	Same as above.	---
A.1.2	Conditioning of samples; temperature (°C)	Same as above.	N/A
A.1.3	Mounting of samples	Same as above.	N/A
A.1.4	Test flame (see IEC 60695-11-3)	Same as above.	N/A
	Flame A, B, C or D	Same as above.	---
A.1.5	Test procedure	Same as above.	N/A
A.1.6	Compliance criteria	Same as above.	N/A
	Sample 1 burning time (s)	Same as above.	---
	Sample 2 burning time (s)	Same as above.	---
	Sample 3 burning time (s)	Same as above.	---
A.2	Flammability test for fire enclosures of movable equipment having a total mass not exceeding 18 kg, and for material and components located inside fire enclosures (see 4.7.3.2 and 4.7.3.4)		N/A
A.2.1	Samples, material.....	Certified components used. (see appended table 1.5.1.)	---
	Wall thickness (mm).....	Same as above.	---
A.2.2	Conditioning of samples; temperature (°C)	Same as above.	N/A
A.2.3	Mounting of samples	Same as above.	N/A
A.2.4	Test flame (see IEC 60695-11-4)	Same as above.	N/A
	Flame A, B or C	Same as above.	---
A.2.5	Test procedure	Same as above.	N/A
A.2.6	Compliance criteria	Same as above.	N/A
	Sample 1 burning time (s)	Same as above.	---
	Sample 2 burning time (s)	Same as above.	---
	Sample 3 burning time (s)	Same as above.	---
A.2.7	Alternative test acc. to IEC 60695-11-5, cl. 5 and 9	Same as above.	N/A
	Sample 1 burning time (s)	Same as above.	---
	Sample 2 burning time (s)	Same as above.	---
	Sample 3 burning time (s)	Same as above.	---
A.3	Hot flaming oil test (see 4.6.2)	Certified components used.	N/A

TRF No. IEC60950_1F

IEC 60950-1			
Clause	Requirement + Test	Result - Remark	Verdict

		(see appended table 1.5.1.)	
A.3.1	Mounting of samples	Same as above.	N/A
A.3.2	Test procedure	Same as above.	N/A
A.3.3	Compliance criterion	Same as above.	N/A

B	ANNEX B, MOTOR TESTS UNDER ABNORMAL CONDITIONS (see 4.7.2.2 and 5.3.2)		N/A
B.1	General requirements	No motor provided.	N/A
	Position	Same as above.	—
	Manufacturer	Same as above.	—
	Type	Same as above.	—
	Rated values	Same as above.	—
B.2	Test conditions	Same as above.	N/A
B.3	Maximum temperatures	Same as above.	N/A
B.4	Running overload test	Same as above.	N/A
B.5	Locked-rotor overload test	Same as above.	N/A
	Test duration (days)	Same as above.	—
	Electric strength test: test voltage (V)	Same as above.	—
B.6	Running overload test for d.c. motors in secondary circuits	Same as above.	N/A
B.6.1	General	Same as above.	N/A
B.6.2	Test procedure	Same as above.	N/A
B.6.3	Alternative test procedure	Same as above.	N/A
B.6.4	Electric strength test; test voltage (V)	Same as above.	N/A
B.7	Locked-rotor overload test for d.c. motors in secondary circuits	Same as above.	N/A
B.7.1	General	Same as above.	N/A
B.7.2	Test procedure	Same as above.	N/A
B.7.3	Alternative test procedure	Same as above.	N/A
B.7.4	Electric strength test; test voltage (V)	Same as above.	N/A
B.8	Test for motors with capacitors	Same as above.	N/A
B.9	Test for three-phase motors	Same as above.	N/A
B.10	Test for series motors	Same as above.	N/A
	Operating voltage (V)	Same as above.	—

C	ANNEX C, TRANSFORMERS (see 1.5.4 and 5.3.3)	P
----------	--	----------

TRF No. IEC60950_1F

IEC 60950-1			
Clause	Requirement + Test	Result - Remark	Verdict

	Position	(see appended table 1.5.1)	---
	Manufacturer	(see appended table 1.5.1)	---
	Type	(see appended table 1.5.1)	---
	Rated values	(see appended table 1.5.1)	---
	Method of protection.....	By protection circuit.	---
C.1	Overload test	(see appended table 5.3)	P
C.2	Insulation	(see appended tables 5.2 and C2)	P
	Protection from displacement of windings.....	(see appended tables 5.2 and C2)	P

D	ANNEX D, MEASURING INSTRUMENTS FOR TOUCH-CURRENT TESTS (see 5.1.4)		P
D.1	Measuring instrument	Figure D.1 used.	P
D.2	Alternative measuring instrument	Not applicable.	N/A

E	ANNEX E, TEMPERATURE RISE OF A WINDING (see 1.4.13)	N/A
----------	--	------------

F	ANNEX F, MEASUREMENT OF CLEARANCES AND CREEPAGE DISTANCES (see 2.10 and Annex G)	P
----------	---	----------

G	ANNEX G, ALTERNATIVE METHOD FOR DETERMINING MINIMUM CLEARANCES		N/A
G.1	Clearances	Not applicable.	N/A
G.1.1	General	Same as above.	N/A
G.1.2	Summary of the procedure for determining minimum clearances	Same as above.	N/A
G.2	Determination of mains transient voltage (V)	Same as above.	N/A
G.2.1	AC mains supply	Same as above.	N/A
G.2.2	Earthed d.c. mains supplies	Same as above.	N/A
G.2.3	Unearthed d.c. mains supplies	Same as above.	N/A
G.2.4	Battery operation	Same as above.	N/A
G.3	Determination of telecommunication network transient voltage (V)	Same as above.	N/A
G.4	Determination of required withstand voltage (V)	Same as above.	N/A
G.4.1	Mains transients and internal repetitive peaks	Same as above.	N/A
G.4.2	Transients from telecommunication networks	Same as above.	N/A

TRF No. IEC60950_1F

IEC 60950-1			
Clause	Requirement + Test	Result - Remark	Verdict
G.4.3	Combination of transients	Same as above.	N/A
G.4.4	Transients from cable distribution systems	Same as above.	N/A
G.5	Measurement of transient voltages (V)	Same as above.	N/A
	a) Transients from a mains supply	Same as above.	N/A
	For an a.c. mains supply	Same as above.	N/A
	For a d.c. mains supply	Same as above.	N/A
	b) Transients from a telecommunication network	Same as above.	N/A
G.6	Determination of minimum clearances	Same as above.	N/A
H	ANNEX H, IONIZING RADIATION (see 4.3.13)		N/A
J	ANNEX J, TABLE OF ELECTROCHEMICAL POTENTIALS (see 2.6.5.6)		N/A
	Metal(s) used	Class II equipment.	—
K	ANNEX K, THERMAL CONTROLS (see 1.5.3 and 5.3.8)		N/A
K.1	Making and breaking capacity	No thermal controls provided.	N/A
K.2	Thermostat reliability; operating voltage (V)	Same as above.	N/A
K.3	Thermostat endurance test; operating voltage (V)	Same as above.	N/A
K.4	Temperature limiter endurance; operating voltage (V)	Same as above.	N/A
K.5	Thermal cut-out reliability	Same as above.	N/A
K.6	Stability of operation	Same as above.	N/A
L	ANNEX L, NORMAL LOAD CONDITIONS FOR SOME TYPES OF ELECTRICAL BUSINESS EQUIPMENT (see 1.2.2.1 and 4.5.2)		P
L.1	Typewriters	Not such type	N/A
L.2	Adding machines and cash registers	Not such type	N/A
L.3	Erasers	Not such type	N/A
L.4	Pencil sharpeners	Not such type	N/A
L.5	Duplicators and copy machines	Not such type	N/A
L.6	Motor-operated files	Not such type	N/A
L.7	Other business equipment	Continuous operation at rated output load.	P
M	ANNEX M, CRITERIA FOR TELEPHONE RINGING SIGNALS (see 2.3.1)		N/A

TRF No. IEC60950_1F

IEC 60950-1			
Clause	Requirement + Test	Result - Remark	Verdict
M.1	Introduction	No telephone ringing signals provided	N/A
M.2	Method A	Same as above.	N/A
M.3	Method B	Same as above.	N/A
M.3.1	Ringing signal	Same as above.	N/A
M.3.1.1	Frequency (Hz)	Same as above.	---
M.3.1.2	Voltage (V)	Same as above.	---
M.3.1.3	Cadence; time (s), voltage (V)	Same as above.	---
M.3.1.4	Single fault current (mA)	Same as above.	---
M.3.2	Tripping device and monitoring voltage	Same as above.	N/A
M.3.2.1	Conditions for use of a tripping device or a monitoring voltage	Same as above.	N/A
M.3.2.2	Tripping device	Same as above.	N/A
M.3.2.3	Monitoring voltage (V)	Same as above.	N/A
N	ANNEX N, IMPULSE TEST GENERATORS (see 1.5.7.2, 1.5.7.3, 2.10.3.9, 6.2.2.1, 7.3.2, 7.4.3 and Clause G.5)		N/A
N.1	ITU-T impulse test generators	Not used.	N/A
N.2	IEC 60065 impulse test generator	Same as above.	N/A
P	ANNEX P, NORMATIVE REFERENCES		---
Q	ANNEX Q, Voltage dependent resistors (VDRs) (see 1.5.9.1)		P
	- Preferred climatic categories	VDRs is certified component. (See appended table 1.5.1.)	P
	- Maximum continuous voltage	Same as above.	P
	- Combination pulse current	Same as above.	P
	Body of the VDR Test according to IEC60695-11-5	Same as above.	P
	Body of the VDR. Flammability class of material (min V-1)	Same as above.	P
R	ANNEX R, EXAMPLES OF REQUIREMENTS FOR QUALITY CONTROL PROGRAMMES		N/A
R.1	Minimum separation distances for unpopulated coated printed boards (see 2.10.6.2)	Not applicable	N/A
R.2	Reduced clearances (see 2.10.3)	Same as above.	N/A

TRF No. IEC60950_1F

IEC 60950-1			
Clause	Requirement + Test	Result - Remark	Verdict

S	ANNEX S, PROCEDURE FOR IMPULSE TESTING (see 6.2.2.3)		N/A
S.1	Test equipment	Not applicable	N/A
S.2	Test procedure	Same as above.	N/A
S.3	Examples of waveforms during impulse testing	Same as above.	N/A

T	ANNEX T, GUIDANCE ON PROTECTION AGAINST INGRESS OF WATER (see 1.1.2)		N/A
		Not applicable.	---

U	ANNEX U, INSULATED WINDING WIRES FOR USE WITHOUT INTERLEAVED INSULATION (see 2.10.5.4)		P
		Certified source of triple insulated wire used in T1. (See appended table 1.5.1.)	---

V	ANNEX V, AC POWER DISTRIBUTION SYSTEMS (see 1.6.1)		P
V.1	Introduction	IT and TN	P
V.2	TN power distribution systems	230V for Norway	P

W	ANNEX W, SUMMATION OF TOUCH CURRENTS		N/A
W.1	Touch current from electronic circuits	No TELECOMMUNICATION NETWORK connection ports provides.	N/A
W.1.1	Floating circuits	Same as above.	N/A
W.1.2	Earthed circuits	Same as above.	N/A
W.2	Interconnection of several equipments	Same as above.	N/A
W.2.1	Isolation	Same as above.	N/A
W.2.2	Common return, isolated from earth	Same as above.	N/A
W.2.3	Common return, connected to protective earth	Same as above.	N/A

X	ANNEX X, MAXIMUM HEATING EFFECT IN TRANSFORMER TESTS (see clause C.1)		N/A
X.1	Determination of maximum input current	Not applicable	N/A
X.2	Overload test procedure	Same as above	N/A

Y	ANNEX Y, ULTRAVIOLET LIGHT CONDITIONING TEST (see 4.3.13.3)		N/A
----------	--	--	------------

TRF No. IEC60950_1F

IEC 60950-1			
Clause	Requirement + Test	Result - Remark	Verdict
Y.1	Test apparatus	Not applicable.	N/A
Y.2	Mounting of test samples	Same as above.	N/A
Y.3	Carbon-arc light-exposure apparatus	Same as above.	N/A
Y.4	Xenon-arc light exposure apparatus	Same as above.	N/A
Z	ANNEX Z, OVERVOLTAGE CATEGORIES (see 2.10.3.2 and Clause G.2)		P
AA	ANNEX AA, MANDREL TEST (see 2.10.5.8)		N/A
BB	ANNEX BB, CHANGES IN THE SECOND EDITION		
CC	ANNEX CC, Evaluation of integrated circuit (IC) current limiters		N/A
CC.1	General	Not applicable	N/A
CC.2	Test program 1	Same as above.	N/A
CC.3	Test program 2	Same as above.	N/A
CC.4	Test program 3	Same as above.	N/A
CC.5	Compliance	Same as above.	N/A
DD	ANNEX DD, Requirements for the mounting means of rack-mounted equipment		N/A
DD.1	General	Not applicable	N/A
DD.2	Mechanical strength test, variable N	Same as above.	N/A
DD.3	Mechanical strength test, 250N, including end stops	Same as above.	N/A
DD.4	Compliance	Same as above.	N/A
EE	ANNEX EE, Household and home/office document/media shredders		N/A
EE.1	General	Not applicable	N/A
EE.2	Markings and instructions	Same as above.	N/A
	Use of markings or symbols	Same as above.	N/A
	Information of user instructions, maintenance and/or servicing instructions	Same as above.	N/A
EE.3	Inadvertent reactivation test	Same as above.	N/A
EE.4	Disconnection of power to hazardous moving parts:	Same as above.	N/A
	Use of markings or symbols	Same as above.	N/A

TRF No. IEC60950_1F

IEC 60950-1			
Clause	Requirement + Test	Result - Remark	Verdict
EE.5	Protection against hazardous moving parts	Same as above.	N/A
	Test with test finger (Figure 2A)	Same as above.	N/A
	Test with wedge probe (Figure EE1 and EE2)	Same as above.	N/A

IEC 60950-1			
Clause	Requirement + Test	Result - Remark	Verdict

1.5.1	TABLE: List of critical components					P
Object/part No	Manufacturer/ trademark	Type/model	Technical data	Standard (Edition / year)	Mark(s) of conformity ¹⁾	
1) Plastic Enclosure	SABIC Innovative Plastics	SE1X(GG)(f1)	Min. V-1, min. 2.0 mm thickness, 105°C	UL 94	UL	
2) Replaceable Plug holder material	SABIC Innovative Plastics	SE1X(GG)(f1)	Min. V-1, min. 2.0 mm thickness, 105°C	UL 94	UL	
3) PCB	Interchangeable	Interchangeable	Min. V-0, min. 130°C	UL 796	UL	
4) Fuse (FS1)	Conquer Electronics Co Ltd	MST-series	T1.6A, 250Vac	IEC / EN 60127-1, IEC / EN 60127-3, UL 248	VDE, UL	
(Alternate)	Ever Island Electric Co Ltd & Walter Electric	2010 series	T1.6A, 250Vac	IEC / EN 60127-1, IEC / EN 60127-3, UL 248	VDE, UL	
(Alternate)	Hollyland Co Ltd.	5ET	T1.6A, 250Vac	IEC / EN 60127-1, IEC / EN 60127-3, UL 248	VDE, UL	
(Alternate)	Bel Fuse Inc.	RST-series	T1.6A, 250Vac	IEC / EN 60127-1, IEC / EN 60127-3, UL 248	VDE, UL	
(Alternate)	Littelfuse Wickmann Werke	392	T1.6A, 250Vac	IEC / EN 60127-1, IEC / EN 60127-3, UL 248	VDE, UL	
5) Varistor (MV1) (optional)	Centra Science Corp.	CNR-14V511K, CNR-14D511K	320Vac, 410Vdc, (Flame class of body coating complied with V-0)	IEC 61051-1, IEC 61051-2, IEC 61051-2-2, UL 1449 3rd SPD type 3 approved	VDE, UL	
(alternate)	Centra Science Corp.	CNR-10V471K, CNR-14D471K	300Vac, 385Vdc, (Flame class of body coating complied with V-0)	IEC 61051-1, IEC 61051-2, IEC 61051-2-2, UL 1449 3rd SPD type 3 approved	VDE, UL	
(alternate)	Joyin Co Ltd	10N511K,	320Vac,	IEC 61051-1,	VDE, UL	

TRF No. IEC60950_1F

IEC 60950-1			
Clause	Requirement + Test	Result - Remark	Verdict

1.5.1	TABLE: List of critical components					P
Object/part No	Manufacturer/ trademark	Type/model	Technical data	Standard (Edition / year)	Mark(s) of conformity ¹⁾	
		14N511K, 14S511K	418Vdc, (Flame class of body coating complied with V- 0)	IEC 61051-2, IEC 61051-2-2, UL 1449 3rd, IEC 60950- 1:2005, Annex Q.		
(alternate)	Joyin Co Ltd	14N471K, 10N471K	300Vac, 385Vdc, (Flame class of body coating complied with V- 0)	IEC 61051-1, IEC 61051-2, IEC 61051-2-2, UL 1449 3rd, IEC 60950- 1:2005, Annex Q.	VDE, UL	
(alternate)	Thinking Electronic Industrial Co Ltd	TVR 14471, TVR 10471-V	300Vac, 385Vdc, (Flame class of body coating complied with V- 0)	IEC 61051-1, IEC 61051-2, IEC 61051-2-2, UL 1449 3rd, IEC 60950- 1:2005, Annex Q.	VDE, UL	
(alternate)	Thinking Electronic Industrial Co Ltd	TVR 1471 (for VDE), TVR 10471K (for UL)	300Vac, 385Vdc, (Flame class of body coating complied with V- 0)	IEC 61051-1, IEC 61051-2, IEC 61051-2-2, UL 1449 3rd SPD type 3 approved	VDE, UL	
(alternate)	Thinking Electronic Industrial Co Ltd	TVR 14511	320Vac, 410Vdc, (Flame class of body coating complied with V- 0)	IEC 61051-1, IEC 61051-2, IEC 61051-2-2, UL 1449 3rd, IEC 60950- 1:2005, Annex Q.	VDE, UL	
(alternate)	Thinking Electronic Industrial Co Ltd	TVR10511 (for VDE), TVR 10511K (for UL)	320Vac, 410Vdc, (Flame class of body coating complied with V- 0)	IEC 61051-1, IEC 61051-2, IEC 61051-2-2, UL 1449 3rd SPD type 3 approved	VDE, UL	
(alternate)	Ceramate Technical Co Ltd	GNR 14D511K	320Vac, 410Vdc, (Flame class of body coating complied with V- 0)	IEC 61051-1, IEC 61051-2, IEC 61051-2-2, UL 1449 3rd SPD type 3 approved	VDE, UL	
(alternate)	Ceramate Technical Co	GNR 14D471K,	300Vac, 385Vdc,	IEC 61051-1, IEC 61051-2,	VDE, UL	

TRF No. IEC60950_1F

IEC 60950-1			
Clause	Requirement + Test	Result - Remark	Verdict

1.5.1	TABLE: List of critical components					P
Object/part No.	Manufacturer/ trademark	Type/model	Technical data	Standard (Edition / year)	Mark(s) of conformity ¹⁾	
9) Storage Capacitor (C1)	Interchangeable	Interchangeable	33 μ F, min. 400V, min. 105°C	--	--	
10) MOSFET (Q1)	Interchangeable	Interchangeable	Min. 4A, min. 600V	--	--	
11) Photo coupler (U1)	Everlight Electronics Co Ltd	EL817	Dti=0.5mm Int. dcr=6.0mm Ext. dcr=7.7mm, thermal cycling test, 110°C	IEC/EN 60950-1, EN 60747-5-2 UL 1577	VDE, UL	
(alternate)	Lite-On Technology Corp	LTV-817	Dti =0.8mm Ext. dcr=7.8mm, thermal cycling test, 100°C	IEC/EN 60950-1, EN 60747-5-2 UL 1577	VDE, UL	
(alternate)	Bright Led Electronics Corp	BPC-817 A/B/C/D/L BPC-817 S BPC-817 M	Dti=0.4mm Ext. dcr=7.0mm, thermal cycling test, 100°C	IEC/EN 60950-1, EN 60747-5-2 UL 1577	VDE, UL	
(alternate)	Cosmo Electronics Corp	K1010	Dti=0.6mm Int. dcr=4.0mm Ext. dcr=5.0mm, thermal cycling test, 115°C	IEC/EN 60950-1, EN 60747-5-2 UL 1577	VDE, UL	
(alternate)	Renesas Electronics Corporation	PS2561-1	Dti=0.4mm Ext. dcr=7.0mm, thermal cycling test, 5000V, 100°C	IEC/EN 60950-1, EN 60747-5-2 UL 1577	VDE, UL	
12) Bridging-Capacitor (CY1) (optional)	Walsin Technology Corp	AH	Max. 1000 pF, Min. 250 V, min. 125°C, Y1	IEC 60384-14 EN 60384-14: 2005 UL 60384-14	VDE, UL	
(alternate)	Success Electronics Co Ltd	SE SB	Max. 1000 pF, Min. 250 V, min. 125°C, Y1	IEC 60384-14 EN 60384-14: 2005 UL 60384-14	VDE, UL	
(alternate)	TDK-EPC Corporation	CD	Max. 1000 pF, Min. 250 V, min. 125°C, Y1	IEC 60384-14 EN 60384-14: 2005 UL 60384-14	VDE, UL	
(alternate)	Haohua Electronic Co	CT7	Max. 1000 pF, Min. 250 V, min.	IEC 60384-14 EN 60384-14:	VDE, UL	

TRF No. IEC60950_1F

IEC 60950-1			
Clause	Requirement + Test	Result - Remark	Verdict

1.5.1	TABLE: List of critical components					P
Object/part No.	Manufacturer/ trademark	Type/model	Technical data	Standard (Edition / year)	Mark(s) of conformity ¹⁾	
			125°C, Y1	2005 UL 60384-14		
(alternate)	Xiangtail Electronic (Shenzhen) Co Ltd	YO-series	Max. 1000 pF, Min. 250 V, min. 125°C, Y1	IEC 60384-14 EN 60384-14: 2005 UL 60384-14	VDE, UL	
(alternate)	Juhong ELE company	JB-serie	Max. 1000 pF, Min. 250 V, min. 85°C, Y1	IEC 60384-14 EN 60384-14: 2005 UL 60384-14	VDE, UL	
13) Current sense resistor (RS12, RS13, RS14) (for models 6A-181WP09, 6A-181WP12, 6A-181WP15, 6A-181WP24, 6A-161WP09, 6A-161WP12, 6A-161WP15, 6A-161WP24)	Interchangeabl e	Interchangeable	3.3 ohm, 1/4W.	--	--	
14) Current sense resistor (RS12, RS13, RS14) (for models 6A-181WP18, 6A-161WP18)	Interchangeabl e	Interchangeable	3.6 ohm, 1/4W.	--	--	
15) Current sense resistor (RS12) (for models 6A- 181WP05, 6A- 181WP20, 6A- 161WP05, 6A- 161WP20)	Interchangeabl e	Interchangeable	4.7 ohm, 1/4W.	--	--	
16) Current sense resistor (RS13, RS14) (for models 6A- 181WP05, 6A- 161WP05)	Interchangeabl e	Interchangeable	3.3 ohm, 1/4W.	--	--	

TRF No. IEC60950_1F

















IEC 60950-1			
Clause	Requirement + Test	Result - Remark	Verdict

1.5.1	TABLE: List of critical components					P
Object/part No.	Manufacturer/ trademark	Type/model	Technical data	Standard (Edition / year)	Mark(s) of conformity ¹⁾	
17) Current sense resistor (RS13, RS14) (for models 6A-181WP20, 6A-161WP20)	Interchangeable	Interchangeable	3.6ohm, 1/4W.	--	--	
18) Transformer (T1) (For models 6A-181WP05, 6A-161WP05)	ENG Electric Co Ltd	XF00914	Class B	--	--	
(For models 6A-181WP09, 6A-181WP12, 6A-181WP15, 6A-161WP09, 6A-161WP12, 6A-161WP15)	ENG Electric Co Ltd	XF00915	Class B	--	--	
(For models 6A-181WP18, 6A-181WP20, 6A-181WP24, 6A-161WP18, 6A-161WP20, 6A-161WP24)	ENG Electric Co Ltd	XF00934	Class B	--	--	
14a) Bobbin	Chang Chun Plastics Co Ltd	T375J	Phenolic, V-0, min. thickness 0.71 mm, 150°C	UL94, UL 746C	UL	
(alternate)	Sumitomo Bakelite Co Ltd	PM-9820	Phenolic, V-0, min. thickness 0.71 mm, 150°C	UL94, UL 746C	UL	
14b) Tape	3M Company Electrical Markets DIV (EMD)	1350F-(#), 1350T-1	130°C	UL 510	UL	
(alternate)	Bondtec Pacific Co Ltd	370S	130°C	UL 510	UL	
14c) Triple Insulated wire	Great Leoflon Industrial Co Ltd	TRW(B) series	130°C	IEC/EN 60950-1 UL 2353	VDE, UL	
Supplementary information:						
¹⁾ Provided evidence ensures the agreed level of compliance. See OD-CB2039.						

TRF No. IEC60950_1F

IEC 60950-1			
Clause	Requirement + Test	Result - Remark	Verdict

1.5.1	TABLE: Opto Electronic Devices	P
Manufacturer: (See appended tables 1.5.1)		
Type.....: (See appended tables 1.5.1)		
Separately tested.....: (See appended tables 1.5.1)		
Bridging insulation: (See appended tables 1.5.1)		
External creepage distance.....: (See appended tables 1.5.1)		
Internal creepage distance: (See appended tables 1.5.1)		
Distance through insulation.....: (See appended tables 1.5.1)		
Tested under the following conditions.....: (See appended tables 1.5.1)		
Input.....: (See appended tables 1.5.1)		
Output.....: (See appended tables 1.5.1)		
supplementary information		

1.6.2	TABLE: Electrical data (in normal conditions)						P
U (V)	I (A)	I _{rated} (A)	P (W)	Fuse #	I _{fuse} (A)	Condition/status	
Model No.: 6A-181WP05							
90/50Hz	0.35	--	18.75	FS1	0.35	5V  3.0A	
100/50Hz	0.32	0.6	18.55	FS1	0.32	5V  3.0A	
240/50Hz	0.19	0.6	18.30	FS1	0.19	5V  3.0A	
254/50Hz	0.18	--	18.40	FS1	0.18	5V  3.0A	
264/50Hz	0.18	--	18.30	FS1	0.18	5V  3.0A	
90/60Hz	0.35	--	18.75	FS1	0.35	5V  3.0A	
100/60Hz	0.33	0.6	18.55	FS1	0.33	5V  3.0A	
240/60Hz	0.19	0.6	18.30	FS1	0.19	5V  3.0A	
254/60Hz	0.19	--	18.40	FS1	0.19	5V  3.0A	
264/60Hz	0.18	--	18.30	FS1	0.18	5V  3.0A	
Model No.: 6A-181WP09							
90/50Hz	0.39	--	21.7	FS1	0.39	9V  2.0A	
100/50Hz	0.35	0.6	21.4	FS1	0.35	9V  2.0A	
240/50Hz	0.21	0.6	21.1	FS1	0.21	9V  2.0A	
254/50Hz	0.20	--	21.0	FS1	0.20	9V  2.0A	
264/50Hz	0.20	--	20.9	FS1	0.20	9V  2.0A	
90/60Hz	0.39	--	21.7	FS1	0.39	9V  2.0A	
100/60Hz	0.36	0.6	21.4	FS1	0.36	9V  2.0A	

TRF No. IEC60950_1F

IEC 60950-1						
Clause	Requirement + Test				Result - Remark	Verdict
240/60Hz	0.21	0.6	21.0	FS1	0.21	9V $\overline{\text{---}}$ 2.0A
254/60Hz	0.20	--	21.1	FS1	0.20	9V $\overline{\text{---}}$ 2.0A
264/60Hz	0.20	--	21.0	FS1	0.20	9V $\overline{\text{---}}$ 2.0A
Model No.: 6A-181WP15						
90/50Hz	0.38	--	21.4	FS1	0.38	15V $\overline{\text{---}}$ 1.2A
100/50Hz	0.35	0.6	21.2	FS1	0.35	15V $\overline{\text{---}}$ 1.2A
240/50Hz	0.21	0.6	20.7	FS1	0.21	15V $\overline{\text{---}}$ 1.2A
254/50Hz	0.20	--	20.6	FS1	0.20	15V $\overline{\text{---}}$ 1.2A
264/50Hz	0.19	--	20.6	FS1	0.19	15V $\overline{\text{---}}$ 1.2A
90/60Hz	0.39	--	21.4	FS1	0.39	15V $\overline{\text{---}}$ 1.2A
100/60Hz	0.36	0.6	21.2	FS1	0.36	15V $\overline{\text{---}}$ 1.2A
240/60Hz	0.21	0.6	20.7	FS1	0.21	15V $\overline{\text{---}}$ 1.2A
254/60Hz	0.20	--	20.6	FS1	0.20	15V $\overline{\text{---}}$ 1.2A
264/60Hz	0.20	--	20.6	FS1	0.20	15V $\overline{\text{---}}$ 1.2A
Model No.: 6A-181WP18						
90/50Hz	0.38	--	20.87	FS1	0.38	18V $\overline{\text{---}}$ 1.0A
100/50Hz	0.35	0.6	20.68	FS1	0.35	18V $\overline{\text{---}}$ 1.0A
240/50Hz	0.21	0.6	20.30	FS1	0.21	18V $\overline{\text{---}}$ 1.0A
254/50Hz	0.20	--	20.30	FS1	0.20	18V $\overline{\text{---}}$ 1.0A
264/50Hz	0.19	--	20.30	FS1	0.19	18V $\overline{\text{---}}$ 1.0A
90/60Hz	0.38	--	20.87	FS1	0.38	18V $\overline{\text{---}}$ 1.0A
100/60Hz	0.36	0.6	20.68	FS1	0.36	18V $\overline{\text{---}}$ 1.0A
240/60Hz	0.21	0.6	20.30	FS1	0.21	18V $\overline{\text{---}}$ 1.0A
254/60Hz	0.20	--	20.30	FS1	0.20	18V $\overline{\text{---}}$ 1.0A
264/60Hz	0.20	--	20.30	FS1	0.20	18V $\overline{\text{---}}$ 1.0A
Model No.: 6A-181WP24						
90/50Hz	0.38	--	21.12	FS1	0.38	24V $\overline{\text{---}}$ 0.75A
100/50Hz	0.35	0.6	20.94	FS1	0.35	24V $\overline{\text{---}}$ 0.75A
240/50Hz	0.21	0.6	20.50	FS1	0.21	24V $\overline{\text{---}}$ 0.75A
254/50Hz	0.20	--	20.50	FS1	0.20	24V $\overline{\text{---}}$ 0.75A
264/50Hz	0.19	--	20.50	FS1	0.19	24V $\overline{\text{---}}$ 0.75A
90/60Hz	0.39	--	21.12	FS1	0.39	24V $\overline{\text{---}}$ 0.75A
100/60Hz	0.36	0.6	20.96	FS1	0.36	24V $\overline{\text{---}}$ 0.75A
240/60Hz	0.21	0.6	20.50	FS1	0.21	24V $\overline{\text{---}}$ 0.75A
254/60Hz	0.20	--	20.50	FS1	0.20	24V $\overline{\text{---}}$ 0.75A

TRF No. IEC60950_1F

IEC 60950-1						
Clause	Requirement + Test				Result - Remark	Verdict
264/60Hz	0.20	--	20.50	FS1	0.20	24V  0.75A
supplementary information						

2.1.1.5 c) 1)	TABLE: max. V, A, VA test					P
Voltage (rated) (V)	Current (rated) (A)	Voltage (max.) (V)	Current (max.) (A)	VA (max.) (VA)		
Model No.: 6A-181WP05						
5	3	5.18	3.99	18.96		
Model No.: 6A-181WP09						
9	2	9.14	2.81	24.91		
Model No.: 6A-181WP24						
24	0.75	24.05	1.31	31.29		
supplementary information						
Input Condition: 240Vac, 60Hz						

2.1.1.5 c) 2)	TABLE: stored energy			N/A
Capacitance C (µF)	Voltage U (V)		Energy E (J)	
supplementary information				

2.2	TABLE: evaluation of voltage limiting components in SELV circuits				P
Component (measured between)	max. voltage (V) (normal operation)		Voltage Limiting Components		
	V peak	V d.c.			
Model No.: 6A-181WP05					
T1 (7) – RTN	37.4	--	--		
Model No.: 6A-181WP15					
T1 (7) – RTN	45.3	--	--		
	34.4	--	CS5		
	--	16.4	D1		

TRF No. IEC60950_1F

IEC 60950-1			
Clause	Requirement + Test	Result - Remark	Verdict
Model No.: 6A-181WP24			
T1 (7) – RTN	76.4	--	--
	59.6	--	CS5
	--	25.4	D1, RS20
Fault test performed on voltage limiting components	Voltage measured (V) in SELV circuits (V peak or V d.c.)		
Model No.: 6A-181WP15			
CS5 short	18.4Vdc (Normal)		
D1 short	0 (Unit shutdown)		
Model No.: 6A-181WP24			
D1 short	0 (Unit shutdown)		
RS20 short	26.0Vdc (Normal)		
supplementary information Input Condition: 240Vac, 60Hz			

2.5	TABLE: Limited power sources					P
Model No.: 6A-181WP05						
Circuit output tested: 5V \approx 3.0A						
Note: Measured Uoc (V) with all load circuits disconnected:						
Components	Sample No.	Uoc (V)	I _{sc} (A)		VA	
			Meas.	Limit	Meas.	Limit
Normal Condition	2	5.18	3.99	≤ 8	18.96	≤ 100
Single Fault: RS5 Sc	2	0	0	≤ 8	0	≤ 100
Single Fault: RS5 Oc	2	6.40	0	≤ 8	0	≤ 100
Single Fault: U1(1-2) Sc	2	9.10	0	≤ 8	0	≤ 100
Single Fault: RS19 Sc	2	5.22	0	≤ 8	0	≤ 100
Single Fault: RS12 Sc	2	0	0	≤ 8	0	≤ 100
Model No.: 6A-181WP09						
Circuit output tested: 9V \approx 2.0A						
Note: Measured Uoc (V) with all load circuits disconnected:						
Components	Sample No.	Uoc (V)	I _{sc} (A)		VA	

TRF No. IEC60950_1F

IEC 60950-1				
Clause	Requirement + Test		Result - Remark	Verdict

			Meas.	Limit	Meas.	Limit
Normal Condition	13	9.14	2.81	≤ 8	24.91	≤ 100
Single Fault: RS5 Sc	13	0	0	≤ 8	0	≤ 100
Single Fault: RS5 Oc	13	12.34	0	≤ 8	0	≤ 100
Single Fault: U1(1-2) Sc	13	20.0	0	≤ 8	0	≤ 100
Single Fault: RS19 Sc	13	9.14	0	≤ 8	0	≤ 100
Single Fault: RS12 Sc	13	0	0	≤ 8	0	≤ 100

Model No.: 6A-181WP24

Circuit output tested: 24V $\overline{\overline{\text{---}}}$ 0.75A

Note: Measured Uoc (V) with all load circuits disconnected:

Components	Sample No.	Uoc (V)	I _{sc} (A)		VA	
			Meas.	Limit	Meas.	Limit
Normal Condition	19	24.05	1.31	≤ 8	31.29	≤ 100
Single Fault: RS5 Sc	19	0	0	≤ 8	0	≤ 100
Single Fault: RS5 Oc	19	26.70	0	≤ 8	0	≤ 100
Single Fault: U1 (1-2) Sc	19	35.01	0	≤ 8	0	≤ 100
Single Fault: RS19 Sc	19	24.05	0	≤ 8	0	≤ 100
Single Fault: RS12 Sc	19	0	0	≤ 8	0	≤ 100

supplementary information

Input Condition: 264Vac, 60Hz

Sc=Short circuit, Oc=Open circuit

2.10.2	Table: working voltage measurement			P
Location	RMS voltage (V)	Peak voltage (V)	Comments	
Model No.: 6A-181WP05				
T1 (5-7)	269	456	--	
T1 (5-6,RTN)	276	460	--	

TRF No. IEC60950_1F

IEC 60950-1			
Clause	Requirement + Test	Result - Remark	Verdict
T1 (4-7)	227	364	--
T1 (4-6,RTN)	227	336	--
T1 (2-7)	205	380	--
T1 (2-6,RTN)	205	372	--
T1 (1-7)	207	420	--
T1 (1-6,RTN)	210	448	--
Model No.: 6A-181WP15			
T1 (5-7)	295	512	--
T1 (5-6,RTN)	307	528	--
T1 (4-7)	239	392	--
T1 (4-6,RTN)	239	348	--
T1 (2-7)	194	364	--
T1 (2-6,RTN)	190	348	--
T1 (1-7)	193	356	--
T1 (1-6,RTN)	194	356	--
Model No.: 6A-181WP24			
T1 (5-7)	290	540	--
T1 (5-6,RTN)	310	564	Max. RMS & Vpeak
T1 (4-7)	242	416	--
T1 (4-6,RTN)	239	352	--
T1 (2-7)	194	376	--
T1 (2-6,RTN)	191	348	--
T1 (1-7)	191	352	--
T1 (1-6,RTN)	193	404	--
CY1 (Pri.-Sec.)	190	348	--
U1 (3-1)	207	368	--
U1 (3-2)	207	368	--
U1 (4-1)	205	368	--
U1 (4-2)	205	368	--
supplementary information: Input Condition: 240Vac, 60Hz			

2.10.3 and 2.10.4	TABLE: Clearance and creepage distance measurements	P
--------------------------	--	----------

TRF No. IEC60950_1F

IEC 60950-1						
Clause	Requirement + Test	Result - Remark			Verdict	
Clearance (cl) and creepage distance (cr) at/of/between	U peak (V)	U r.m.s. (V)	Required cl (mm)	cl (mm)	Required cr (mm)	cr (mm)
Functional:						
L trace → N trace Before Current Fuse (FS1)	420	250	1.5	3.7	2.5	3.7
L → MV1 (with 10N)	420	250	1.5	3.7	2.5	3.7
L trace → MV1 trace	420	250	1.5	2.5	2.5	2.5
Between fuse trace (FS1)	420	250	1.5	3.0	2.5	3.0
Between fuse (FS1)	420	250	1.5	3.1	2.5	3.1
Basic/supplementary:						
--	--	--	--	--	--	--
Reinforced:						
Primary components (with 10N) → secondary components (with 10N)	420	250	4.0	See as below	5.0	See as below
HS1 → CY1 Sec. pin	420	250	4.0	5.2	5.0	5.2
Input blade pin → access parts (US plug) (only plug)	420	250	4.0	5.6	5.0	5.6
Input blade pin → access parts (China plug) (only plug)	420	250	4.0	5.6	5.0	5.6
Input blade pin → access parts (AU plug) (only plug)	420	250	4.0	5.3	5.0	5.3
Input blade pin → access parts (EU plug) (only plug)	420	250	4.0	5.6	5.0	5.6
Input blade pin → access parts (UK plug) (only plug)	420	250	4.0	5.5	5.0	5.5
Input blade pin → access parts (US plug)	420	250	4.0	5.8	5.0	5.8
Input blade pin → access parts (China plug)	420	250	4.0	5.8	5.0	5.8
Primary trace → secondary trace	420	250	4.0	See as below	5.0	See as below
Between CY1	420	250	4.0	7.4	5.0	7.4
Between U1	420	250	4.0	7.6	5.0	7.6
CY1 (Pri.) → RS15 (with 1.1mm width cut groove)	420	250	4.0	6.2	5.0	8.9
supplementary information						

TRF No. IEC60950_1F

IEC 60950-1					
Clause	Requirement + Test	Result - Remark			Verdict
2.10.5	TABLE: Distance through insulation measurements				P
Distance through insulation (DTI) at/of:	U peak (V)	U rms (V)	Test voltage (V)	Required DTI (mm)	DTI (mm)
Enclosure Material used: (see appended tables 1.5.1)	564	310	3000Vac	0.4	2.0
Photo coupler (U1) (see appended tables 1.5.1)	420	250	3000Vac	0.4	¹⁾
Polyester tape of T1 (one layer for test) Material used: (see appended tables 1.5.1)	564	310	3000Vac	2 layers	2 layers
supplementary information ¹⁾ (see appended table 1.5.1)					

4.3.8	TABLE: Batteries							N/A	
The tests of 4.3.8 are applicable only when appropriate battery data is not available									
Is it possible to install the battery in a reverse polarity position?									
	Non-rechargeable batteries			Rechargeable batteries					
	Discharging		Un-intentional charging	Charging		Discharging		Reversed charging	
	Meas. current	Manuf. Specs.		Meas. current	Manuf. Specs.	Meas. current	Manuf. Specs.	Meas. current	Manuf. Specs.
Max. current during normal condition									
Max. current during fault condition									
Test results:							Verdict		
- Chemical leaks									
- Explosion of the battery									
- Emission of flame or expulsion of molten metal									
- Electric strength tests of equipment after completion of tests									
supplementary information									

TRF No. IEC60950_1F

IEC 60950-1			
Clause	Requirement + Test	Result - Remark	Verdict

--

4.3.8	TABLE: Batteries	N/A
Battery category	(Lithium, NiMh, NiCad, Lithium Ion ...)	
Manufacturer		
Type / model.....		
Voltage		
Capacity.....	mAh	
Tested and Certified by (incl. Ref. No.)		
Circuit protection diagram:		
supplementary information		

MARKINGS AND INSTRUCTIONS (1.7.13)	
Location of replaceable battery	
Language(s)	
Close to the battery	
In the servicing instructions	
In the operating instructions	
supplementary information	

4.5	TABLE: Thermal requirements						P
Supply voltage (V)	90Vac/ 60Hz	264Vac/ 60Hz	90Vac/ 60Hz	264Vac/ 60Hz	--	--	---
Ambient Tmin (°C)	--	--	--	--	--	--	---
Ambient Tmax (°C)	--	--	--	--	--	--	---
Maximum measured temperature T of part/at	T (°C)						Allowed T _{max} (°C)
Model No.: 6A-181WP05							
Test condition	Horizon tal	Horizon tal	Vertical	Vertical	--	--	--

TRF No. IEC60950_1F

IEC 60950-1						
Clause	Requirement + Test				Result - Remark	Verdict
Input plug holder (near blade)	64.7	59.3	63.6	58.7	--	105
MV1 body	59.9	54.3	61.0	54.7	--	85
LF1 coil	77.0	64.4	76.9	64.3	--	105
CX1 body	66.4	60.0	66.3	59.8	--	100
C1 body	72.1	65.9	71.6	65.5	--	105
HS1 body near Q1	69.0	67.3	67.9	66.1	--	130
T1 primary side coil	76.9	73.8	75.9	72.8	--	110
T1 secondary side coil	74.0	71.5	72.9	70.4	--	110
T1 core	74.6	72.6	73.6	71.6	--	110
U1 body	71.4	69.4	71.0	69.0	--	100
CY1 body	64.3	62.9	63.0	61.6	--	85
PCB body near T1	74.0	71.7	73.0	70.8	--	130
HS2 body near D1	82.6	80.5	77.2	75.9	--	130
PCB body near BD1	75.8	67.0	75.5	66.7	--	130
Output wire body	52.4	51.8	50.4	49.8	--	80
Inside of enclosure body near T1	58.5	57.3	57.4	56.2	--	105
Surface of enclosure body near T1	49.0	48.6	47.0	46.5	--	95
Ambient air	40.3	40.3	40.0	40.0	--	--
Model No.: 6A-181WP09						
Input plug holder (near blade)	68.9	62.4	68.3	61.7	--	105
MV1 body	64.6	56.8	65.2	56.7	--	85
LF1 coil	87.9	69.2	87.2	68.8	--	105
CX1 body	69.5	61.4	69.4	61.2	--	100
C1 body	76.4	68.2	75.3	67.2	--	105
HS1 body near Q1	72.0	69.2	70.6	67.8	--	130
T1 primary side coil	83.9	79.7	82.6	78.5	--	110
T1 secondary side coil	78.7	75.5	77.1	73.9	--	110
T1 core	77.9	75.5	76.2	73.8	--	110
U1 body	73.0	71.6	72.2	70.8	--	100
CY1 body	62.7	61.4	61.8	60.2	--	85
PCB body near T1	75.0	74.3	74.5	72.9	--	130
HS2 body near D1	82.8	82.9	80.6	80.4	--	130
PCB body near BD1	80.1	69.3	79.1	68.3	--	130
Output wire body	53.1	52.9	51.4	50.8	--	80
Inside of enclosure body near T1	63.5	61.6	61.6	59.8	--	105

TRF No. IEC60950_1F

IEC 60950-1							
Clause	Requirement + Test			Result - Remark			Verdict
Surface of enclosure body near T1	53.4	52.4	50.6	49.6	--		95
Ambient air	40.0	40.1	40.3	40.4	--		--
Model No.: 6A-181WP24							
Input plug holder (near blade)	68.3	60.1	69.5	60.9	--		105
MV1 body	65.3	55.9	68.0	57.3	--		85
LF1 coil	87.7	64.8	89.3	66.5	--		105
CX1 body	73.0	61.8	73.9	62.8	--		100
C1 body	78.3	68.3	79.0	69.2	--		105
HS1 body near Q1	77.1	68.1	76.5	68.2	--		130
T1 primary side coil	80.0	76.7	79.7	76.9	--		110
T1 secondary side coil	78.7	74.8	76.6	74.1	--		110
T1 core	77.5	71.9	77.1	72.0	--		110
U1 body	69.0	67.5	69.6	68.5	--		100
CY1 body	63.8	60.1	63.6	60.5	--		85
PCB body near T1	71.5	69.8	71.2	70.1	--		130
PCB body near BD1	82.2	67.6	83.8	69.2	--		130
Output wire body	53.2	51.8	51.8	51.1	--		80
Inside of enclosure body near T1	58.8	56.8	56.1	55.1	--		105
Surface of enclosure body near T1	50.2	48.5	48.1	47.2	--		95
Ambient air	40.3	40.3	40.3	40.3	--		--
Temperature T of winding:	t ₁ (°C)	R ₁ (Ω)	t ₂ (°C)	R ₂ (Ω)	T (°C)	Allowed T _{max} (°C)	Insulation class
supplementary information							

4.5.5	TABLE: Ball pressure test of thermoplastic parts		P
	Allowed impression diameter (mm)	≤ 2 mm	
Part	Test temperature (°C)	Impression diameter (mm)	
Input plug holder, SE1X, 2.05 x 2	125	1.74	
supplementary information:			

4.7	TABLE: Resistance to fire	P
-----	---------------------------	---

TRF No. IEC60950_1F

IEC 60950-1					
Clause	Requirement + Test	Result - Remark	Verdict		
Part	Manufacturer of material	Type of material	Thickness (mm)	Flammability class	Evidence
(see appended tables 1.5.1)	--	--	--	--	--
supplementary information					

5.1	TABLE: touch current measurement			P
Measured between:	Measured (mA)	Limit (mA)	Comments/conditions	
Model No.: 6A-181WP05				
Enclosure with foil	0.01	0.25	"e" - C; P1 - N; Pri S. - N/A	
Enclosure with foil	0.01	0.25	"e" - C; P1 - R; Pri S. - N/A	
Output (-)	0.07	0.25	"e" - C; P1 - N; Pri S. - N/A	
Output (-)	0.07	0.25	"e" - C; P1 - R; Pri S. - N/A	
supplementary information				
Input Condition: 264Vac, 60Hz				

5.2	TABLE: Electric strength tests, impulse tests and voltage surge tests			P
Test voltage applied between:	Voltage shape (AC, DC, impulse, surge)	Test voltage (V)	Breakdown Yes / No	
Model No.: 6A-181WP05, 6A-181WP09, 6A-181WP24				
Functional:				
Basic/supplementary:				
Reinforced:				
Unit: Primary / SELV	DC	4242	No	
Unit: Primary / Enclosure with foil	DC	4242	No	
supplementary information				
<ul style="list-style-type: none"> All testing Including after Humidity required of clause 2.9, there are including unit, transformer and all material of transformer, see appended tables 1.5.1 				

TRF No. IEC60950_1F

IEC 60950-1			
Clause	Requirement + Test	Result - Remark	Verdict

5.3	TABLE: Fault condition tests					P
	Ambient temperature (°C)		25°C, if no further indicated			---
	Power source for EUT: Manufacturer, model/type, output rating		--			---
Component No.	Fault	Supply voltage (V)	Test time	Fuse #	Fuse current (A)	Observation
Model No.: 6A-181WP05 (with 20A breaker)						
T1 (1-2)	Short	240Vac	30min	FS1	1.6	Unit cycle protection immediately, NT, NB, NC. I/P: 0.01↔0.04A
T1 (6-7)	Short	240Vac	30min	FS1	1.6	Unit shutdown immediately, NT, NB, NC. I/P: 0.01A
U1 (1-2)	Short	240Vac	30min	FS1	1.6	Unit cycle protection immediately, NT, NB, NC. I/P: 0.01↔0.07A
U1 (3-4)	Short	240Vac	30min	FS1	1.6	Unit shutdown immediately, NT, NB, NC. I/P: 0.01A
U1 (1)	Open	240Vac	30min	FS1	1.6	Unit cycle protection immediately, NT, NB, NC. I/P: 0.01↔0.07A
US1 (2-5)	Short	240Vac	1sec	FS1	1.6	FS1 opened, NT, NB, NC, RF. I/P: 0A
Q1 (G-S)	Short	240Vac	30min	FS1	1.6	Unit shutdown immediately, NT, NB, NC. I/P: 0.01A
Q1 (G-D)	Short	240Vac	1sec	FS1	1.6	FS1 opened, Q1 damaged, NT, NB, NC, RF. I/P: 0A
Q1 (D-S)	Short	240Vac	1sec	FS1	1.6	FS1 opened, Q1 damaged, NT, NB, NC, RF. I/P: 0A
C1	Short	240Vac	1sec	FS1	1.6	FS1 opened, NT, NB, NC, RF. I/P: 0A
DB1 (1-2)	Short	240Vac	1sec	FS1	1.6	FS1 opened, NT, NB, NC, RF. I/P: 0A
+5V-RTN	Short	240Vac	30min	FS1	1.6	Unit cycle protection immediately, NT, NB, NC. I/P: 0.01↔0.07A

TRF No. IEC60950_1F

IEC 60950-1						
Clause	Requirement + Test				Result - Remark	Verdict
Output (+5V/3A)	Overload	240Vac	2h:44m	FS1	1.6	CT at 3.8A increased to 3.9A Unit shutdown, NT, NB, NC, T1=87°C, U1=80°C, Amb.=24.9°C I/P: 0.20A
Model No.: 6A-181WP05 (with 32A breaker for United Kingdom (UK) required)						
US1 (2-5)	Short	240Vac	1sec	FS1	1.6	FS1 opened, NT, NB, NC, RF. I/P: 0A
Q1 (G-D)	Short	240Vac	1sec	FS1	1.6	FS1 opened, Q1 damaged, NT, NB, NC, RF. I/P: 0A
Q1 (D-S)	Short	240Vac	1sec	FS1	1.6	FS1 opened, Q1 damaged, NT, NB, NC, RF. I/P: 0A
C1	Short	240Vac	1sec	FS1	1.6	FS1 opened, NT, NB, NC, RF. I/P: 0A
DB1 (1-2)	Short	240Vac	1sec	FS1	1.6	FS1 opened, NT, NB, NC, RF. I/P: 0A
Model No.: 6A-181WP09 (with 20A breaker)						
T1 (1-2)	Short	240Vac	30min	FS1	1.6	Unit cycle protection immediately, NT, NB, NC. I/P: 0.01↔0.07A
T1 (6-7)	Short	240Vac	30min	FS1	1.6	Unit cycle protection immediately, NT, NB, NC. I/P: 0.01↔0.06A
+9V-RTN	Short	240Vac	30min	FS1	1.6	Unit cycle protection immediately, NT, NB, NC. I/P: 0.01↔0.05A
Output (+9V/2A)	Overload	240Vac	2h:44m	FS1	1.6	CT at 2.7A increased to 2.75A Unit shutdown, NT, NB, NC, T1=92°C, U1=80°C, Amb.=23.8°C I/P: 0.23A
Model No.: 6A-181WP24 (with 20A breaker)						
T1 (1-2)	Short	240Vac	30min	FS1	1.6	Unit cycle protection immediately, NT, NB, NC, I/P: 0.01↔0.07A
T1 (6-7)	Short	240Vac	30min	FS1	1.6	Unit cycle protection immediately, NT, NB, NC. I/P: 0.01↔0.12A
+24V-RTN	Short	240Vac	30min	FS1	1.6	Unit cycle protection immediately, NT, NB, NC.

TRF No. IEC60950_1F

IEC 60950-1						
Clause	Requirement + Test				Result - Remark	Verdict
						I/P: 0.01↔0.04A
Output (+24V/0.75A)	Overload	240Vac	2h:14m	FS1	1.6	CT at 1A increased to 1.1A Unit shutdown, NT, NB, NC, T1=86°C,U1=78°C, Amb.=24.1°C I/P: 0.21A
supplementary information						
<p>Comments Key:</p> <p>NB: No indication of dielectric breakdown</p> <p>YB: Dielectric breakdown (indicate time and location)</p> <p>NC: Cheesecloth remained intact</p> <p>YC: Cheesecloth charred or flamed</p> <p>NT: Tissue paper remained intact</p> <p>RF: Repeat all fuse result were the same.</p> <p>YT: Tissue paper charred or flamed</p> <p>IP: Internal protection operated (list component)</p> <p>I/P: Input current</p>						

IEC 60950-1			
Clause	Requirement + Test	Result - Remark	Verdict

C.2	TABLE: transformers						P
Loc.	Tested insulation	Working voltage peak / V (2.10.2)	Working voltage rms / V (2.10.2)	Required electric strength (5.2)	Required clearance / mm (2.10.3)	Required creepage distance / mm (2.10.4)	Required distance thr. insul. (2.10.5)
T1	Primary to Secondary (Reinforced)	564	310	3000Vac	4.4	6.2	0.4
T1	Secondary to Core (Reinforced)	564	310	3000Vac	4.4	6.2	0.4
Loc.	Tested insulation			Test voltage/ V	Measured clearance / mm	Measured creepage dist./ mm	Measured distance thr. insul. / mm; number of layers
T1	Primary to Secondary (Reinforced)			3000Vac	6.3	6.3	Triple wires used
T1	Secondary to Core (Reinforced)			3000Vac	6.3	6.3	Triple wires used
supplementary information							
<ul style="list-style-type: none"> All testing Including after Humidity required of clause 2.9, there are including unit, transformer and all material of transformer, see appended tables 1.5.1 							

C.2	TABLE: transformers	P
-----	---------------------	---

Transformer:

ENG Electric Co Ltd Type XF00914

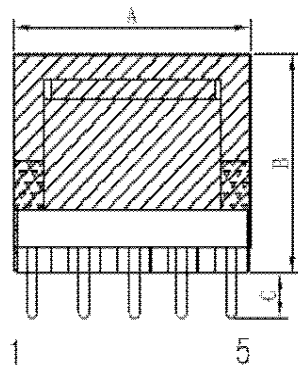

ELEVATION VIEW

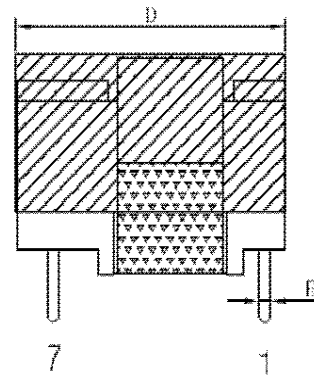

SIDB VIEW

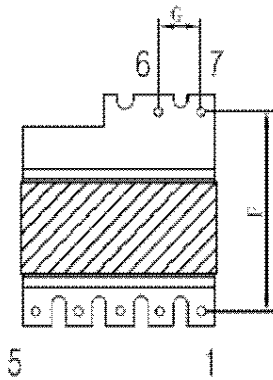

BOTTOM VIEW

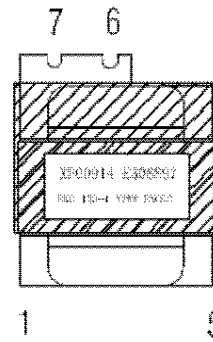

TOP VIEW

NOTE:

1. PIN3 CUT OFF 1/2.
2. 底部装研磨CORE用3M1350P-1 14mm*1L TAPE加工, CORE TAPE 9.5mm* 3TS.
3. 成品后顶部次级磁芯贴“L”层胶带24mm*45mm*1L REF, 图示TOP VIEW, 多余胶带反折回次级线包内, 再沿线包方向包外围胶带14mm*2TS.
4. 产品需真空含浸.
5. 产品标签贴于PIN1-5侧磁芯顶部 (图示).

DIM	A	B	C	D	E	F	G	H	I	J	K	L
	MAX	MAX	± 0.3	MAX	±0.1	± 0.3	± 0.3					
SPEC	21.0	18.0	3.5	24.0	0.7	18.5	4.0					

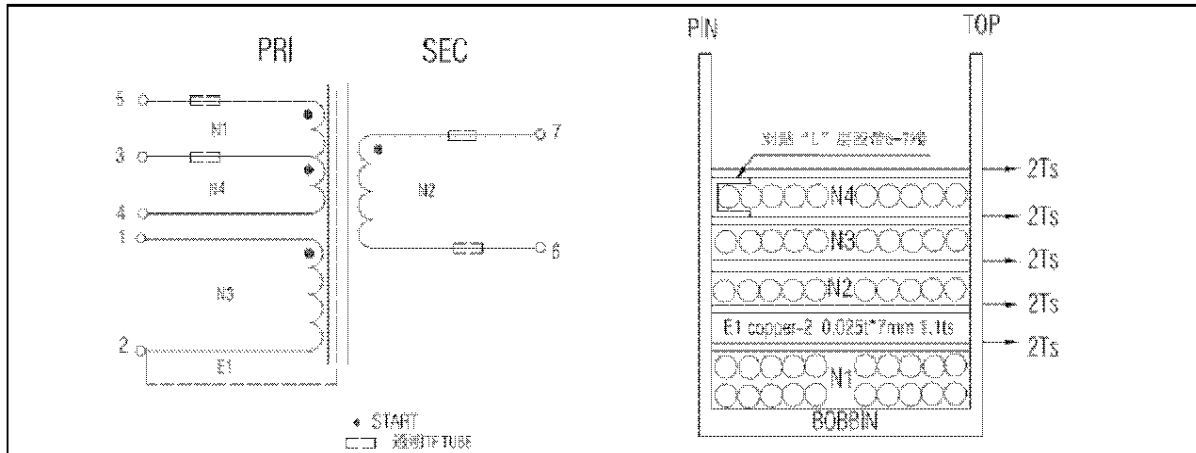

4.WINDING TABLE:

Winding No (组别)	Margin Tape (档墙胶布)	PIN (脚位)	Wire&Wire Copper (线径)	Turns (圈数)	Winding Tape	Tape Layer (胶带层次)	Tube
N1		5-3	2UEW0.270*1P	55Ts	密绕	2TS	26L*10mm/318L*10mm
E1		Copper-2	0.025t*7mm	1.1TS	背胶	2TS	
N2		7-6	0.80*1P 三层绝缘线	5Ts	密绕	2TS	18L*10mm 18L*10mm
N3		1-2	2UEW0.150*2P	16Ts	密绕	2TS	
N4		3-4	2UEW0.270*1P	25Ts	密绕	2TS	26L*10mm

NOTE:

- 1.PIN朝内制作。
2. N1密绕二层，起，尾线不可交叉。
- 3.N3线包到骨架需有1.3mm的距离，附件图片。
- 3.N4 密绕一层，起线加套管，绕N4前先PING-7端加“L”层胶带，待N4绕完后折回线包内3.2mm MIN。
4. E1为内铜箔（背胶一层反折2mm MIN)0.025t*7mm1.1TS, 接引线 ϕ 0.25*1P于PIN2。

底部研磨CORE用3M1350F-1 14mm*1L TAPE加工

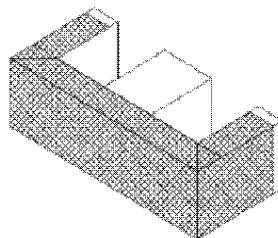

IEC 60950-1			
Clause	Requirement + Test	Result - Remark	Verdict

List of test equipment used:

A completed list of used test equipment shall be provided in the Test Reports when a Manufacturer Testing Laboratory according to TMP/CTF stage 1 or WMT/CTF stage 2 procedure has been used.

Clause	Measurement / testing	Testing / measuring equipment / material used	Range used	Calibration date

Note: No necessary to list all test equipment with CBTL procedure.

IEC 60950-1			
Clause	Requirement + Test	Result - Remark	Verdict
National Difference of IEC 60950-1:2005 (Second Edition) + Am 1: 2009 + Am 2: 2013			

ATTACHMENT TO TEST REPORT IEC 60950-1 EUROPEAN GROUP DIFFERENCES AND NATIONAL DIFFERENCES Information technology equipment – Safety – Part 1: General requirements	
Differences according to	EN 60950-1:2006/A11:2009/A1:2010/A12:2011/A2:2013
Attachment Form No.....	EU_GD_IEC60950_1F
Attachment Originator	SGS Fimko Ltd
Master Attachment	Date 2014-02
Copyright © 2014 IEC System for Conformity Testing and Certification of Electrical Equipment (IECEE), Geneva, Switzerland. All rights reserved.	

EN 60950-1:2006/A11:2009/A1:2010/A12:2011/A2:2013 – CENELEC COMMON MODIFICATIONS
--

IEC 60950-1, GROUP DIFFERENCES (CENELEC common modifications EN)		
	Clauses, subclauses, notes, tables and figures which are additional to those in IEC60950-1 and it's amendmets are prefixed "Z"	P
Contents (A2:2013)	Add the following annexes: Annex ZA (normative) Normative references to international publications with their corresponding European publications Annex ZB (normative) Special national conditions Annex ZD (informative) IEC and CENELEC code designations for flexible cords	P
General	Delete all the "country" notes in the reference document (IEC 60950-1:2005) according to the following list: 1.4.8 Note 2 1.5.1 Note 2 & 3 1.5.7.1 Note 1.5.8 Note 2 1.5.9.4 Note 1.7.2.1 Note 4, 5 & 6 2.2.3 Note 2.2.4 Note 2.3.2 Note 2.3.2.1 Note 2 2.3.4 Note 2 2.6.3.3 Note 2 & 3 2.7.1 Note 2.10.3.2 Note 2 2.10.5.13 Note 3 3.2.1.1 Note 3.2.4 Note 3. 2.5.1 Note 2 4.3.6 Note 1 & 2 4.7 Note 4 4.7.2.2 Note 4.7.3.1 Note 2 5.1.7.1 Note 3 & 4 5.3.7 Note 1 6 Note 2 & 5 6.1.2.1 Note 2 6.1.2.2 Note 6.2.2 Note 6.2.2.1 Note 2 6.2.2.2 Note 7.1 Note 3 7.2 Note 7.3 Note 1 & 2 G.2.1 Note 2 Annex H Note 2	P
General (A1:2010)	Delete all the "country" notes in the reference document (IEC 60950-1:2005/A1:2010) according to the following list: 1.5.7.1 Note 6.1.2.1 Note 2 6.2.2.1 Note 2 EE.3 Note	P
General	Delete all the "country" notes in the reference document (IEC 60950-	P

IEC 60950-1			
Clause	Requirement + Test	Result - Remark	Verdict
National Difference of IEC 60950-1:2005 (Second Edition) + Am 1: 2009 + Am 2: 2013			
(A2:2013)	1:2005/A2:2013) according to the following list: 2.7.1 Note * 2.10.3.1 Note 2 6.2.2. Note * Note of secretary: Text of Common Modification remains unchanged.		
1.1.1 (A1:2010)	Replace the text of NOTE 3 by the following. NOTE 3 The requirements of EN 60065 may also be used to meet safety requirements for multimedia equipment. See IEC Guide 112, Guide on the safety of multimedia equipment. For television sets EN 60065 applies.		P
1.3.Z1	Add the following subclause: 1.3.Z1Exposure to excessive sound pressure The apparatus shall be so designed and constructed as to present no danger when used for its intended purpose, either in normal operating conditions or under fault conditions, particularly providing protection against exposure to excessive sound pressures from headphones or earphones. NOTE Z1 A new method of measurement is described in EN 50332-1, Sound system equipment: Headphones and earphones associated with portable audio equipment - Maximum sound pressure level measurement methodology and limit considerations - Part 1: General method for "one package equipment", and in EN 50332-2, Sound system equipment: Headphones and earphones associated with portable audio equipment - Maximum sound pressure level measurement methodology and limit considerations - Part 2: Guidelines to associate sets with headphones coming from different manufacturers.	Not PORTABLE SOUND SYSTEM.	N/A
(A12:2011)	In EN 60950-1:2006/A12:2011 Delete the addition of 1.3.Z1 / EN 60950-1:2006 Delete the definition 1.2.3.Z1 / EN 60950-1:2006 /A1:2010	Deleted.	
1.5.1 (Added info*)	Add the following NOTE: NOTE Z1 The use of certain substances in electrical and electronic equipment is restricted within the EU: see Directive 2002/95/EC. New Directive 2011/65/11 *	Added.	P
1.7.2.1 (A1:2010)	In addition, for a PORTABLE SOUND SYSTEM, the instructions shall include a warning that excessive sound pressure from earphones and headphones can cause hearing loss.	Not PORTABLE SOUND SYSTEM.	N/A
1.7.2.1 (A12.2011)	In EN 60950-1:2006/A12:2011 Delete NOTE Z1 and the addition for Portable Sound System. Add the following clause and annex to the existing	Not PORTABLE SOUND SYSTEM.	N/A

IEC 60950-1			
Clause	Requirement + Test	Result - Remark	Verdict
National Difference of IEC 60950-1:2005 (Second Edition) + Am 1: 2009 + Am 2: 2013			

	standard and amendments.		
	Zx Protection against excessive sound pressure from personal music players		N/A
	<p>Zx.1 General</p> <p>This sub-clause specifies requirements for protection against excessive sound pressure from personal music players that are closely coupled to the ear. It also specifies requirements for earphones and headphones intended for use with personal music players.</p> <p>A personal music player is a portable equipment for personal use, that:</p> <ul style="list-style-type: none"> - is designed to allow the user to listen to recorded or broadcast sound or video; and - primarily uses headphones or earphones that can be worn in or on or around the ears; and - allows the user to walk around while in use. <p>NOTE 1 Examples are hand-held or body-worn portable CD players, MP3 audio players, mobile phones with MP3 type features, PDA's or similar equipment.</p> <p>A personal music player and earphones or headphones intended to be used with personal music players shall comply with the requirements of this sub-clause.</p> <p>The requirements in this sub-clause are valid for music or video mode only.</p> <p>The requirements do not apply:</p> <ul style="list-style-type: none"> - while the personal music player is connected to an external amplifier; or - while the headphones or earphones are not used. <p>NOTE 2 An external amplifier is an amplifier which is not part of the personal music player or the listening device, but which is intended to play the music as a standalone music player.</p> <p>The requirements do not apply to:</p> <ul style="list-style-type: none"> - hearing aid equipment and professional equipment; <p>NOTE 3 Professional equipment is equipment sold through special sales channels. All products sold through normal electronics stores are considered not to be professional equipment.</p> <ul style="list-style-type: none"> - Analogue personal music players (personal music players without any kind of digital processing of the sound signal) that are brought to the market before the end of 2015. 	Not PORTABLE SOUND SYSTEM.	N/A

IEC 60950-1			
Clause	Requirement + Test	Result - Remark	Verdict
National Difference of IEC 60950-1:2005 (Second Edition) + Am 1: 2009 + Am 2: 2013			

	<p>NOTE 4 This exemption has been allowed because this technology is falling out of use and it is expected that within a few years it will no longer exist. This exemption will not be extended to other technologies.</p> <p>For equipment which is clearly designed or intended for use by young children, the limits of EN 71-1 apply.</p>		
	<p>Zx.2 Equipment requirements</p> <p>No safety provision is required for equipment that complies with the following:</p> <ul style="list-style-type: none"> - equipment provided as a package (personal music player with its listening device), where - the acoustic output $L_{Aeq,T}$ is ≤ 85 dBA measured while playing the fixed "programme simulation noise" as described in EN 50332-1; and - a personal music player provided with an analogue electrical output socket for a listening device, where the electrical output is ≤ 27 mV measured as described in EN 50332-2, while playing the fixed "programme simulation noise" as described in EN 50332-1. <p>NOTE 1 Wherever the term acoustic output is used in this clause, the 30 s A-weighted equivalent sound pressure level $L_{Aeq,T}$ is meant. See also Zx.5 and Annex Zx.</p> <p>All other equipment shall:</p> <ol style="list-style-type: none"> a) protect the user from unintentional acoustic outputs exceeding those mentioned above; and b) have a standard acoustic output level not exceeding those mentioned above, and automatically return to an output level not exceeding those mentioned above when the power is switched off; and c) provide a means to actively inform the user of the increased sound pressure when the equipment is operated with an acoustic output exceeding those mentioned above. Any means used shall be acknowledged by the user before activating a mode of operation which allows for an acoustic output exceeding those mentioned above. The acknowledgement does not need to be repeated more than once every 20 h of cumulative listening time; and <p>NOTE 2 Examples of means include visual or audible signals. Action from the user is always required.</p> <p>NOTE 3 The 20 h listening time is the</p>	Not PORTABLE SOUND SYSTEM.	N/A

IEC 60950-1			
Clause	Requirement + Test	Result - Remark	Verdict
National Difference of IEC 60950-1:2005 (Second Edition) + Am 1: 2009 + Am 2: 2013			

	<p>accumulative listening time, independent how often and how long the personal music player has been switched off.</p> <p>d) have a warning as specified in Zx.3; and</p> <p>e) not exceed the following:</p> <ol style="list-style-type: none"> 1) equipment provided as a package (player with its listening device), the acoustic output shall be ≤ 100 dBA measured while playing the fixed "programme simulation noise" described in EN 50332-1; and 2) a personal music player provided with an analogue electrical output socket for a listening device, the electrical output shall be ≤ 150 mV measured as described in EN 50332-2, while playing the fixed "programme simulation noise" described in EN 50332-1. <p>For music where the average sound pressure (long term $L_{Aeq,T}$) measured over the duration of the song is lower than the average produced by the programme simulation noise, the warning does not need to be given as long as the average sound pressure of the song is below the basic limit of 85 dBA. In this case T becomes the duration of the song.</p> <p>NOTE 4 Classical music typically has an average sound pressure (long term $L_{Aeq,T}$) which is much lower than the average programme simulation noise. Therefore, if the player is capable to analyse the song and compare it with the programme simulation noise, the warning does not need to be given as long as the average sound pressure of the song is below the basic limit of 85 dBA.</p> <p>For example, if the player is set with the programme simulation noise to 85 dBA, but the average music level of the song is only 65 dBA, there is no need to give a warning or ask an acknowledgement as long as the average sound level of the song is not above the basic limit of 85 dBA.</p>		
	<p>Zx.3 Warning</p> <p>The warning shall be placed on the equipment, or on the packaging, or in the instruction manual and shall consist of the following:</p> <ul style="list-style-type: none"> - the symbol of Figure 1 with a minimum height of 5 mm; and - the following wording, or similar: <p>"To prevent possible hearing damage, do not listen at high volume levels for long periods."</p>	Not PORTABLE SOUND SYSTEM.	N/A

IEC 60950-1			
Clause	Requirement + Test	Result - Remark	Verdict
National Difference of IEC 60950-1:2005 (Second Edition) + Am 1: 2009 + Am 2: 2013			

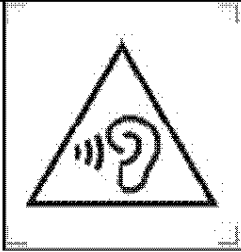
			
	<p>Figure 1 – Warning label (IEC 60417-6044)</p> <p>Alternatively, the entire warning may be given through the equipment display during use, when the user is asked to acknowledge activation of the higher level.</p>		
	Zx.4 Requirements for listening devices (headphones and earphones)		N/A
	<p>Zx.4.1 Wired listening devices with analogue input</p> <p>With 94 dBA sound pressure output $L_{Aeq,T}$, the input voltage of the fixed “programme simulation noise” described in EN 50332-2 shall be ≥ 75 mV.</p> <p>This requirement is applicable in any mode where the headphones can operate (active or passive), including any available setting (for example built-in volume level control).</p> <p>NOTE The values of 94 dBA – 75 mV correspond with 85dBA – 27 mV and 100 dBA – 150 mV.</p>	Not PORTABLE SOUND SYSTEM.	N/A
	<p>Zx.4.2 Wired listening devices with digital input</p> <p>With any playing device playing the fixed “programme simulation noise” described in EN 50332-1 (and respecting the digital interface standards, where a digital interface standard exists that specifies the equivalent acoustic level), the acoustic output $L_{Aeq,T}$ of the listening device shall be ≤ 100 dBA.</p> <p>This requirement is applicable in any mode where the headphones can operate, including any available setting (for example built-in volume level control, additional sound feature like equalization, etc.).</p> <p>NOTE An example of a wired listening device with digital input is a USB headphone.</p>	Not PORTABLE SOUND SYSTEM.	N/A
	<p>Zx.4.3 Wireless listening devices</p> <p>In wireless mode:</p> <ul style="list-style-type: none"> - with any playing and transmitting device playing the fixed programme simulation noise described in EN 50332-1; and - respecting the wireless transmission standards, where an air interface standard 	Not PORTABLE SOUND SYSTEM.	N/A

IEC 60950-1			
Clause	Requirement + Test	Result - Remark	Verdict
National Difference of IEC 60950-1:2005 (Second Edition) + Am 1: 2009 + Am 2: 2013			

	<p>exists that specifies the equivalent acoustic level; and</p> <ul style="list-style-type: none"> - with volume and sound settings in the listening device (for example built-in volume level control, additional sound feature like equalization, etc.) set to the combination of positions that maximize the measured acoustic output for the abovementioned programme simulation noise, the acoustic output $L_{Aeq,T}$ of the listening device shall be ≤ 100 dBA. <p>NOTE An example of a wireless listening device is a Bluetooth headphone.</p>		
	<p>Zx.5 Measurement methods</p> <p>Measurements shall be made in accordance with EN 50332-1 or EN 50332-2 as applicable. Unless stated otherwise, the time interval T shall be 30 s.</p> <p>NOTE Test method for wireless equipment provided without listening device should be defined.</p>	Not PORTABLE SOUND SYSTEM.	N/A
2.7.1	<p>Replace the subclause as follows:</p> <p>Basic requirements</p> <p>To protect against excessive current, short-circuits and earth faults in PRIMARY CIRCUITS, protective devices shall be included either as integral parts of the equipment or as parts of the building installation, subject to the following, a), b) and c):</p> <ul style="list-style-type: none"> a) except as detailed in b) and c), protective devices necessary to comply with the requirements of 5.3 shall be included as parts of the equipment; b) for components in series with the mains input to the equipment such as the supply cord, appliance coupler, r.f.i. filter and switch, short-circuit and earth fault protection may be provided by protective devices in the building installation; c) it is permitted for PLUGGABLE EQUIPMENT TYPE B or PERMANENTLY CONNECTED EQUIPMENT, to rely on dedicated overcurrent and short-circuit protection in the building installation, provided that the means of protection, e.g. fuses or circuit breakers, is fully specified in the installation instructions. <p>If reliance is placed on protection in the building installation, the installation instructions shall so state, except that for PLUGGABLE EQUIPMENT TYPE A the building installation shall be regarded as providing protection in accordance with the rating of the wall socket outlet.</p>	Replaced.	P

IEC 60950-1			
Clause	Requirement + Test	Result - Remark	Verdict
National Difference of IEC 60950-1:2005 (Second Edition) + Am 1: 2009 + Am 2: 2013			
2.7.2	This subclause has been declared 'void'.	--	
3.2.3	Delete the NOTE in Table 3A, and delete also in this table the conduit sizes in parentheses.	The equipment is not permanently connected.	N/A
3.2.5.1	<p>Replace "60245 IEC 53" by "H05 RR-F"; "60227 IEC 52" by "H03 VV-F or H03 VVH2-F"; "60227 IEC 53" by "H05 VV-F or H05 VVH2-F2".</p> <p>In Table 3B, replace the first four lines by the following: Up to and including 6 0,75 ^{a)} Over 6 up to and including 10 (0,75) ^{b)} 1,0 Over 10 up to and including 16 (1,0) ^{c)} 1,5 </p> <p>In the conditions applicable to Table 3B delete the words "in some countries" in condition ^{a)}.</p> <p>In NOTE 1, applicable to Table 3B, delete the second sentence.</p>	Direct plug-in equipment.	N/A
3.2.5.1 (A2:2013)	NOTE Z1The harmonised code designations corresponding to the IEC cord types are given in Annex ZD	Direct plug-in equipment.	N/A
3.3.4	<p>In Table 3D, delete the fourth line: conductor sizes for 10 to 13 A, and replace with the following: Over 10 up to and including 16 1,5 to 2,5 1,5 to 4 </p> <p>Delete the fifth line: conductor sizes for 13 to 16 A</p>	The equipment is not permanently connected of provided with a non-detachable power supply cord.	N/A
4.3.13.6 (A1:2010)	<p>Replace the existing NOTE by the following: NOTE Z1 Attention is drawn to: 1999/519/EC: Council Recommendation on the limitation of exposure of the general public to electromagnetic fields 0 Hz to 300 GHz, and 2006/25/EC: Directive on the minimum health and safety requirements regarding the exposure of workers to risks arising from physical agents (artificial optical radiation).</p> <p>Standards taking into account mentioned Recommendation and Directive which demonstrate compliance with the applicable EU Directive are indicated in the OJEC.</p>	No ionizing radiation provided.	N/A
Annex H	<p>Replace the last paragraph of this annex by: At any point 10 cm from the surface of the OPERATOR ACCESS AREA, the dose rate shall not exceed 1 µSv/h (0,1 mR/h) (see NOTE). Account is taken of the background level.</p> <p>Replace the notes as follows: NOTE These values appear in Directive 96/29/Euratom.</p>	No ionizing radiation provided.	N/A

IEC 60950-1			
Clause	Requirement + Test	Result - Remark	Verdict
National Difference of IEC 60950-1:2005 (Second Edition) + Am 1: 2009 + Am 2: 2013			

	Delete NOTE 2.		
Bibliography	Additional EN standards.	No ionizing radiation provided.	N/A

ZA	NORMATIVE REFERENCES TO INTERNATIONAL PUBLICATIONS WITH THEIR CORRESPONDING EUROPEAN PUBLICATIONS		
-----------	--	--	--

ZB ANNEX (normative) SPECIAL NATIONAL CONDITIONS (EN)			
1.2.4.1	In Denmark , certain types of Class I appliances (see 3.2.1.1) may be provided with a plug not establishing earthing conditions when inserted into Danish socket-outlets.	Class II equipment.	N/A
1.2.13.14 (A11:2009)	In Norway and Sweden , for requirements see 1.7.2.1 and 7.3 of this annex.	Not applicable.	N/A
1.5.7.1 (A11:2009)	In Finland, Norway and Sweden , resistors bridging BASIC INSULATION in CLASS I PLUGGABLE EQUIPMENT TYPE A must comply with the requirements in 1.5.7.1. In addition when a single resistor is used, the resistor must withstand the resistor test in 1.5.7.2.	No such Resistors provided.	N/A
1.5.8	In Norway , due to the IT power system used (see annex V, Figure V.7), capacitors are required to be rated for the applicable line-to-line voltage (230 V).	Class II equipment.	N/A
1.5.9.4	In Finland, Norway and Sweden , the third dashed sentence is applicable only to equipment as defined in 6.1.2.2 of this annex.	No such VDR provided.	N/A
1.7.2.1 (A11:2009)	In Finland, Norway and Sweden , CLASS I PLUGGABLE EQUIPMENT TYPE A intended for connection to other equipment or a network shall, if safety relies on connection to protective earth or if surge suppressors are connected between the network terminals and accessible parts, have a marking stating that the equipment must be connected to an earthed mains socket-outlet. The marking text in the applicable countries shall be as follows: In Finland : "Laitte on liitettävä suojakoskettimilla varustettuun pistorasiaan" In Norway : "Apparatet må tilkoples jordet stikkontakt" In Sweden : "Apparaten skall anslutas till jordat uttag" In Norway and Sweden , the screen of the cable distribution system is normally not earthed at the	Class II equipment.	N/A

IEC 60950-1			
Clause	Requirement + Test	Result - Remark	Verdict
National Difference of IEC 60950-1:2005 (Second Edition) + Am 1: 2009 + Am 2: 2013			

	<p>entrance of the building and there is normally no equipotential bonding system within the building. Therefore the protective earthing of the building installation need to be isolated from the screen of a cable distribution system.</p> <p>It is however accepted to provide the insulation external to the equipment by an adapter or an interconnection cable with galvanic isolator, which may be provided by e.g. a retailer.</p> <p>The user manual shall then have the following or similar information in Norwegian and Swedish language respectively, depending on in what country the equipment is intended to be used in:</p> <p>“Equipment connected to the protective earthing of the building installation through the mains connection or through other equipment with a connection to protective earthing – and to a cable distribution system using coaxial cable, may in some circumstances create a fire hazard. Connection to a cable distribution system has therefore to be provided through a device providing electrical isolation below a certain frequency range (galvanic isolator, see EN 60728-11).”</p> <p>NOTE In Norway, due to regulation for installations of cable distribution systems, and in Sweden, a galvanic isolator shall provide electrical insulation below 5 MHz. The insulation shall withstand a dielectric strength of 1,5 kV r.m.s., 50 Hz or 60 Hz, for 1 min.</p> <p>Translation to Norwegian (the Swedish text will also be accepted in Norway):</p> <p>“Utstyr som er koplet til beskyttelsesjord via nettplugg og/eller via annet jordtilkoplede utstyr – og er tilkoplede et kabel-TV nett, kan forårsake brannfare. For å unngå dette skal det ved tilkopling av utstyret til kabel-TV nettet installeres en galvanisk isolator mellom utstyret og kabel-TV nettet.”</p> <p>Translation to Swedish:</p> <p>”Utrustning som är kopplad till skyddsjord via jordat vägguttag och/eller via annan utrustning och samtidigt är kopplad till kabel-TV nät kan i vissa fall medföra risk för brand. För att undvika detta skall vid anslutning av utrustningen till kabel-TV nät galvanisk isolator finnas mellan utrustningen och kabel-TV nätet.”</p>		
1.7.2.1 (A2:2013)	In Denmark , CLASS I PLUGGABLE EQUIPMENT TYPE A intended for connection to other equipment or a network shall, if safety relies on connection to protective earth or if surge	Class II equipment.	N/A

IEC 60950-1			
Clause	Requirement + Test	Result - Remark	Verdict
National Difference of IEC 60950-1:2005 (Second Edition) + Am 1: 2009 + Am 2: 2013			
	suppressors are connected between the network terminals and accessible parts, have a marking stating that the equipment must be connected to an earthed mains socket-outlet. The marking text in Denmark shall be as follows: In Denmark : "Apparatets stikprop skal tilsluttes en stikkontakt med jord, som giver forbindelse til stikproppens jord."		
1.7.5 (A11:2009)	In Denmark , socket-outlets for providing power to other equipment shall be in accordance with the Heavy Current Regulations, Section 107-2-D1, Standard Sheet DK 1-3a, DK 1-5a or DK 1-7a, when used on Class I equipment. For STATIONARY EQUIPMENT the socket-outlet shall be in accordance with Standard Sheet DK 1-1b or DK 1-5a. For CLASS II EQUIPMENT the socket outlet shall be in accordance with Standard Sheet DKA 1-4a.	No socket-outlets provided.	N/A
1.7.5 (A2:2013)	In Denmark , socket-outlets for providing power to other equipment shall be in accordance with the DS 60884-2-D1:2011. For class I equipment the following Standard Sheets are applicable: DK 1-3a, DK 1-1c, DK 1-1d, DK 1-5a or DK 1-7a, with the exception for STATIONARY EQUIPMENT where the socket-outlets shall be in accordance with Standard Sheet DK 1-1b, DK 1-1c, DK 1-1d or DK 1-5a. Socket outlets intended for providing power to Class II apparatus with a rated current of 2,5 A shall be in accordance with DS 60884-2-D1 standard sheet DKA 1-4a. Other current rating socket outlets shall be in compliance with by DS 60884-2-D1 Standard Sheet DKA 1-3a or DKA 1-3b. Justification the Heavy Current Regulations, 6c	No socket-outlets provided.	N/A
2.2.4	In Norway , for requirements see 1.7.2.1, 6.1.2.1 and 6.1.2.2 of this annex.	No TNV circuits provided.	N/A
2.3.2	In Finland, Norway and Sweden there are additional requirements for the insulation. See 6.1.2.1 and 6.1.2.2 of this annex.	No TNV circuits provided.	N/A
2.3.4	In Norway , for requirements see 1.7.2.1, 6.1.2.1 and 6.1.2.2 of this annex.	No TNV circuits provided.	N/A
2.6.3.3	In the United Kingdom , the current rating of the circuit shall be taken as 13 A, not 16 A.	Class II equipment.	N/A
2.7.1	In the United Kingdom , to protect against excessive currents and short-circuits in the PRIMARY CIRCUIT of DIRECT PLUG-IN	Complied check. (see appended table 5.3)	P

IEC 60950-1			
Clause	Requirement + Test	Result - Remark	Verdict
National Difference of IEC 60950-1:2005 (Second Edition) + Am 1: 2009 + Am 2: 2013			
	EQUIPMENT, tests according to 5.3 shall be conducted, using an external protective device rated 30 A or 32 A. If these tests fail, suitable protective devices shall be included as integral parts of the DIRECT PLUG-IN EQUIPMENT, so that the requirements of 5.3 are met.		
2.10.5.13	In Finland, Norway and Sweden , there are additional requirements for the insulation, see 6.1.2.1 and 6.1.2.2 of this annex.	No TNV circuits provided.	N/A
3.2.1.1	In Switzerland , supply cords of equipment having a RATED CURRENT not exceeding 10 A shall be provided with a plug complying with SEV 1011 or IEC 60884-1 and one of the following dimension sheets: SEV 6532-2.1991 Plug Type 15 3P+N+PE 250/400 V, 10 A SEV 6533-2.1991 Plug Type 11 L+N 250 V, 10 A SEV 6534-2.1991 Plug Type 12 L+N+PE 250 V, 10 A In general, EN 60309 applies for plugs for currents exceeding 10 A. However, a 16 A plug and socket-outlet system is being introduced in Switzerland, the plugs of which are according to the following dimension sheets, published in February 1998: SEV 5932-2.1998: Plug Type 25 , 3L+N+PE 230/400 V, 16 A SEV 5933-2.1998: Plug Type 21, L+N, 250 V, 16A SEV 5934-2.1998: Plug Type 23, L+N+PE 250 V, 16 A	Direct plug-in equipment.	N/A
3.2.1.1	In Denmark , supply cords of single-phase equipment having a rated current not exceeding 13 A shall be provided with a plug according to the Heavy Current Regulations, Section 107-2-D1. CLASS I EQUIPMENT provided with socket-outlets with earth contacts or which are intended to be used in locations where protection against indirect contact is required according to the wiring rules shall be provided with a plug in accordance with standard sheet DK 2-1a or DK 2-5a. If poly-phase equipment and single-phase equipment having a RATED CURRENT exceeding 13 A is provided with a supply cord with a plug, this plug shall be in accordance with the Heavy Current Regulations, Section 107-2-D1 or EN 60309-2.	Direct plug-in equipment.	N/A
3.2.1.1 (A2:2013)	In Denmark , supply cords of single-phase equipment having a rated current not exceeding 13 A shall be provided with a plug according to DS 60884-2-D1.	Direct plug-in equipment.	N/A

IEC 60950-1			
Clause	Requirement + Test	Result - Remark	Verdict
National Difference of IEC 60950-1:2005 (Second Edition) + Am 1: 2009 + Am 2: 2013			
	<p>CLASS I EQUIPMENT provided with socket-outlets with earth contacts or which are intended to be used in locations where protection against indirect contact is required according to the wiring rules shall be provided with a plug in accordance with standard sheet DK 2-1a or DK 2-5a.</p> <p>If a single-phase equipment having a RATED CURRENT exceeding 13 A or if a poly-phase equipment is provided with a supply cord with a plug, this plug shall be in accordance with the standard sheets DK 6-1a in DS 60884-2-D1 or EN 60309-2.</p> <p>Justification the Heavy Current Regulations, 6c</p>		
3.2.1.1	<p>In Spain, supply cords of single-phase equipment having a rated current not exceeding 10 A shall be provided with a plug according to UNE 20315:1994.</p> <p>Supply cords of single-phase equipment having a rated current not exceeding 2,5 A shall be provided with a plug according to UNE-EN 50075:1993.</p> <p>CLASS I EQUIPMENT provided with socket-outlets with earth contacts or which are intended to be used in locations where protection against indirect contact is required according to the wiring rules, shall be provided with a plug in accordance with standard UNE 20315:1994.</p> <p>If poly-phase equipment is provided with a supply cord with a plug, this plug shall be in accordance with UNE-EN 60309-2.</p>	Direct plug-in equipment.	N/A
3.2.1.1	<p>In the United Kingdom, apparatus which is fitted with a flexible cable or cord and is designed to be connected to a mains socket conforming to BS 1363 by means of that flexible cable or cord and plug, shall be fitted with a 'standard plug' in accordance with Statutory Instrument 1768:1994 - The Plugs and Sockets etc. (Safety) Regulations 1994, unless exempted by those regulations.</p> <p>NOTE 'Standard plug' is defined in SI 1768:1994 and essentially means an approved plug conforming to BS 1363 or an approved conversion plug.</p>	Direct plug-in equipment.	N/A
3.2.1.1	<p>In Ireland, apparatus which is fitted with a flexible cable or cord and is designed to be connected to a mains socket conforming to I.S. 411 by means of that flexible cable or cord and plug, shall be fitted with a 13 A plug in accordance with Statutory Instrument 525:1997 - National Standards Authority of Ireland (section 28) (13 A Plugs and Conversion Adaptors for Domestic Use) Regulations 1997.</p>	Direct plug-in equipment.	N/A

IEC 60950-1			
Clause	Requirement + Test	Result - Remark	Verdict
National Difference of IEC 60950-1:2005 (Second Edition) + Am 1: 2009 + Am 2: 2013			
3.2.4	In Switzerland , for requirements see 3.2.1.1 of this annex.	Direct plug-in equipment	N/A
3.2.5.1	In the United Kingdom , a power supply cord with conductor of 1,25 mm ² is allowed for equipment with a rated current over 10 A and up to and including 13 A.	Direct plug-in equipment.	N/A
3.3.4	In the United Kingdom , the range of conductor sizes of flexible cords to be accepted by terminals for equipment with a RATED CURRENT of over 10 A up to and including 13 A is: • 1,25 mm ² to 1,5 mm ² nominal cross-sectional area.	The equipment is not permanently connected of provided with a non-detachable power supply cord.	N/A
4.3.6	In the United Kingdom , the torque test is performed using a socket outlet complying with BS 1363 part 1:1995, including Amendment 1:1997 and Amendment 2:2003 and the plug part of DIRECT PLUG-IN EQUIPMENT shall be assessed to BS 1363: Part 1, 12.1, 12.2, 12.3, 12.9, 12.11, 12.12, 12.13, 12.16 and 12.17, except that the test of 12.17 is performed at not less than 125 °C. Where the metal earth pin is replaced by an Insulated Shutter Opening Device (ISOD), the requirements of clauses 22.2 and 23 also apply.	The main plug has been evaluated according to BS 1363-1: 1995 + A1:1997 + A2: 2003+ A3:2007+ A4: 2012, Report No. TP-12069 (TP12100076-ETS)	P
4.3.6	In Ireland , DIRECT PLUG-IN EQUIPMENT is known as plug similar devices. Such devices shall comply with Statutory Instrument 526:1997 - National Standards Authority of Ireland (Section 28) (Electrical plugs, plug similar devices and sockets for domestic use) Regulations, 1997.	The main plug has been evaluated according to BS 1363-1: 1995 + A1:1997 + A2: 2003+ A3:2007+ A4: 2012, Report No. TP-12069 (TP12100076-ETS)	P
5.1.7.1	In Finland, Norway and Sweden TOUCH CURRENT measurement results exceeding 3,5 mA r.m.s. are permitted only for the following equipment: • STATIONARY PLUGGABLE EQUIPMENT TYPE A that is intended to be used in a RESTRICTED ACCESS LOCATION where equipotential bonding has been applied, for example, in a telecommunication centre; and has provision for a permanently connected PROTECTIVE EARTHING CONDUCTOR; and is provided with instructions for the installation of that conductor by a SERVICE PERSON; • STATIONARY PLUGGABLE EQUIPMENT TYPE B; • STATIONARY PERMANENTLY CONNECTED EQUIPMENT.	Touch current does not exceed 3.5mA	N/A
6.1.2.1 (A1:2010)	In Finland, Norway and Sweden , add the following text between the first and second	No TNV circuit provided	N/A

IEC 60950-1			
Clause	Requirement + Test	Result - Remark	Verdict
National Difference of IEC 60950-1:2005 (Second Edition) + Am 1: 2009 + Am 2: 2013			

	<p>paragraph of the compliance clause:</p> <p>If this insulation is solid, including insulation forming part of a component, it shall at least consist of either</p> <ul style="list-style-type: none"> - two layers of thin sheet material, each of which shall pass the electric strength test below, or - one layer having a distance through insulation of at least 0,4 mm, which shall pass the electric strength test below. <p>Alternatively for components, there is no distance through insulation requirements for the insulation consisting of an insulating compound completely filling the casing, so that CLEARANCES and CREEPAGE DISTANCES do not exist, if the component passes the electric strength test in accordance with the compliance clause below and in addition</p> <ul style="list-style-type: none"> - passes the tests and inspection criteria of 2.10.11 with an electric strength test of 1,5 kV multiplied by 1,6 (the electric strength test of 2.10.10 shall be performed using 1,5 kV), and - is subject to ROUTINE TESTING for electric strength during manufacturing, using a test voltage of 1,5 kV. <p>It is permitted to bridge this insulation with an optocoupler complying with 2.10.5.4 b).</p> <p>It is permitted to bridge this insulation with a capacitor complying with EN 60384-14:2005, subclass Y2.</p> <p>A capacitor classified Y3 according to EN 60384-14:2005, may bridge this insulation under the following conditions:</p> <ul style="list-style-type: none"> - the insulation requirements are satisfied by having a capacitor classified Y3 as defined by EN 60384-14, which in addition to the Y3 testing, is tested with an impulse test of 2,5 kV defined in EN 60950-1:2006, 6.2.2.1; - the additional testing shall be performed on all the test specimens as described in EN 60384-14; - the impulse test of 2,5 kV is to be performed before the endurance test in EN 60384-14, in the sequence of tests as described in EN 60384-14. 		
6.1.2.2	In Finland, Norway and Sweden , the exclusions are applicable for PERMANENTLY CONNECTED EQUIPMENT, PLUGGABLE EQUIPMENT TYPE B and equipment intended to be used in a RESTRICTED ACCESS LOCATION where	No TNV circuit provided	N/A

IEC 60950-1			
Clause	Requirement + Test	Result - Remark	Verdict
National Difference of IEC 60950-1:2005 (Second Edition) + Am 1: 2009 + Am 2: 2013			

	equipotential bonding has been applied, e.g. in a telecommunication centre, and which has provision for a permanently connected PROTECTIVE EARTHING CONDUCTOR and is provided with instructions for the installation of that conductor by a SERVICE PERSON.		
7.2	In Finland, Norway and Sweden , for requirements see 6.1.2.1 and 6.1.2.2 of this annex. The term TELECOMMUNICATION NETWORK in 6.1.2 being replaced by the term CABLE DISTRIBUTION SYSTEM.	No cable distribution systems	N/A
7.3 (A11:2009)	In Norway and Sweden , for requirements see 1.2.13.14 and 1.7.2.1 of this annex.	No cable distribution systems	N/A

Annex ZD (informative)

IEC and CENELEC code designations for flexible cords		
Type of flexible cord	Code designations	
	IEC	CENELEC
PVC insulated cords		
Flat twin tinsel cord	60227 IEC 41	H03VH-Y
Light polyvinyl chloride sheathed flexible cord	60227 IEC 52	H03VV-F H03VVH2-F
Ordinary polyvinyl chloride sheathed flexible cord	60277 IEC 53	H05VV-F H05VVH2-F
Rubber insulated cords		
Braided cord	60245 IEC 51	H03RT-F
Ordinary tough rubber sheathed flexible cord	60245 IEC 53	H05RR-F
Ordinary polychloroprene sheathed flexible cord	60245 IEC 57	H05RN-F
Heavy polychloroprene sheathed flexible cord	60245 IEC 66	H07RN-F
Cords having high flexibility		
Rubber insulated and sheathed cord	60245 IEC 86	H03RR-H
Rubber insulated, crosslinked PVC sheathed cord	60245 IEC 87	H03RV4-H
Crosslinked PVC insulated and sheathed cord	60245 IEC 88	H03V4V4-H

Country	Denmark
IECEE Member NCB	UL (Demko)
IEC Standard	IEC 60950-1(ed.2);am1;am2

ATTACHMENT

IEC 60950-1			
Clause	Requirement + Test	Result - Remark	Verdict

National Difference of IEC 60950-1:2005 (Second Edition) + Am 1: 2009 + Am 2: 2013

Corresponding National Standard	DS/EN 60950-1:2006 + A11:2009 + A1:2010 + A12:2011 + A2:2013
Regulatory Requirements	N/A

1.2.4.1	In Denmark , certain types of Class I appliances (see 3.2.1.1) may be provided with a plug not establishing earthing conditions when inserted into Danish socket-outlets.	Class II equipment.	N/A
1.7.5	In Denmark, socket-outlets for providing power to other equipment shall be in accordance with the Heavy Current Regulations, Section 107-2-D1, Standard Sheet DK 1-3a, DK 1-5a or DK 1-7a, when used on Class I equipment. For STATIONARY EQUIPMENT the socket-outlet shall be in accordance with Standard Sheet DK 1-1b or DK 1-5a. For CLASS II EQUIPMENT the socket outlet shall be in accordance with Standard Sheet DKA 1-4a.	No socket-outlets provided.	N/A
3.2.1.1	In Denmark , supply cords of single-phase equipment having a rated current not exceeding 13 A shall be provided with a plug according to the Heavy Current Regulations, Section 107-2-D1. CLASS I EQUIPMENT provided with socket-outlets with earth contacts or which are intended to be used in locations where protection against indirect contact is required according to the wiring rules shall be provided with a plug in accordance with standard sheet DK 2-1a or DK 2-5a. If poly-phase equipment and single-phase equipment having a RATED CURRENT exceeding 13 A is provided with a supply cord with a plug, this plug shall be in accordance with the Heavy Current Regulations, Section 107-2-D1 or EN 60309-2.	Direct plug-in equipment.	N/A

Country	Sweden
IECEE Member NCB	Intertek Semko AB
IEC Standard	IEC 60950-1(ed.2);am1;am2
Corresponding National Standard	SS-EN 60950-1:2006 + A11:2009 + A1:2010 + A12:2011
Regulatory Requirements	N/A

Various	Please see the EN version of the standard where the Swedish National and Special National Deviations are stated.	N/A
---------	--	-----

IEC 60950-1			
Clause	Requirement + Test	Result - Remark	Verdict
National Difference of IEC 60950-1:2005 (Second Edition) + Am 1: 2009 + Am 2: 2013			

ATTACHMENT TO TEST REPORT IEC 60950-1 U.S.A. NATIONAL DIFFERENCES Information technology equipment – Safety – Part 1: General requirements	
Differences according to	UL 60950-1-07(Second Edition) + A1: 2011 + A2: 2014
Attachment Form No.....	US_ND_IEC60950_1F
Attachment Originator	UL
Master Attachment	Date 2014-07
Copyright © 2014 IEC System for Conformity Testing and Certification of Electrical Equipment (IECEE), Geneva, Switzerland. All rights reserved.	

	Special national conditions		
1.1.1	All equipment is designed as to allow installation in accordance with the National Electrical Code (NEC), ANSI/NFPA 70, Canadian Electrical Code (CEC), Part I, CAN/CSA C22.1, and if applicable, the National Electrical Safety Code, IEEE C2	Complied check.	P
	Also, unless marked or otherwise identified, installation is allowed per the Standard for the Protection of Electronic Computer/Data-Processing Equipment, ANSI/NFPA 75	Same as above.	P
1.1.2	Baby monitors are required to additionally comply with ASTM F2951, Consumer Safety Specification for Baby Monitors	Not applicable.	N/A
1.4.14	For Pluggable Equipment Type A, the protection in the installation is assumed to be 20A	Complied check.	P
1.5.5	For lengths exceeding 3.05 m, external interconnecting flexible cord and cable assemblies are required to be a suitable cable type (e.g., DP, CL2) specified in the /NEC	Complied check.	P
	For lengths 3.05 m or less, external interconnecting flexible cord and cable assemblies that are not types specified in the NEC are required to have special construction features and identification markings	Complied check.	P
1.7.1	Equipment for use on a.c. mains supply systems with a neutral and more than one phase conductor (e.g. 120/240 V, 3-wire) require a special marking format for electrical ratings	Not applicable.	N/A
	A voltage rating that exceeds an attachment plug cap rating is only permitted if it does not exceed the extreme operating conditions in Table 2 of CAN/CSA C22.2 No. 235, and	Same as above.	N/A

IEC 60950-1			
Clause	Requirement + Test	Result - Remark	Verdict
National Difference of IEC 60950-1:2005 (Second Edition) + Am 1: 2009 + Am 2: 2013			
	- if it is part of a range that extends into the Table 2 "Normal Operating Conditions"	Same as above.	N/A
	Likewise, a voltage rating is not to be lower than the specified "Normal Operating Conditions," unless it is part of a range that extends into the "Normal Operating Conditions"	Same as above.	N/A
1.7.7	Wiring terminals intended to supply Class 2 outputs in accordance with NEC or CEC Part 1 or NEC are marked with the voltage rating and "Class 2" or equivalent	Not applicable.	N/A
	- Marking is located adjacent to the terminals	Same as above.	N/A
	- Marking is visible during wiring	Same as above.	N/A
2.5	Fuse providing Class 2, Limited Power Source, or TNV current limiting is not operator-accessible unless it is not interchangeable	Not applicable.	N/A
2.6	Equipment with isolated ground (earthing) receptacles is in compliance with NEC 250.146(D) and CEC 10-112 and 10-906(8)	Class II equipment.	N/A
2.7.1	Suitable NEC/CEC branch circuit protection rated at the maximum circuit rating is provided for all standard supply outlets and receptacles (such as supplied in power distribution units) if the supply branch circuit protection is not suitable.	Complied check.	P
	Power distribution transformers distributing power at 100 volts or more, and rated 10 kVA or more, provided with special transformer overcurrent protection	Complied check.	P
3.2	Wiring methods (terminals, leads, etc.) used for the connection of the equipment to the mains is in accordance with the NEC/CEC	Direct plug-in equipment.	N/A
3.2.1	Attachment plugs of power supply cords are rated not less than 125 percent of the rated current of the equipment	Same as above.	N/A
3.2.1.2	Equipment connected to a centralized d.c. power system, and having one pole of the DC mains input terminal connected to the main protective earthing terminal in the equipment comply with special earthing, wiring, marking and installation instruction requirements	Mains from AC source only.	N/A
3.2.3	Permanent connection of equipment to the mains supply by a power supply cord is not permitted, except for certain equipment, such as ATMs	The equipment is not permanently connected.	N/A
3.2.5	Power supply cords are no longer than 4.5 m in length	Direct plug-in equipment.	N/A
	Minimum cord length is 1.5 m, with certain	Same as above.	N/A

IEC 60950-1			
Clause	Requirement + Test	Result - Remark	Verdict
National Difference of IEC 60950-1:2005 (Second Edition) + Am 1: 2009 + Am 2: 2013			

	constructions such as external power supplies allowed to consider both input and output cord lengths into the requirement		
	Flexible power supply cords are compatible with Article 400 of the NEC, and Tables 11 and 12 of the CEC	Same as above.	N/A
3.2.9	Permanently connected equipment has a suitable wiring compartment and wire bending space	Direct plug-in equipment	N/A
3.3	Wiring terminals and associated spacings for field wiring connections comply with CSA C22.2 No. 0	The equipment is not permanently connected or provided with a non-detachable power supply cord.	N/A
3.3.3	Wire binding screws are not attached with conductors larger than 10 AWG (5.3 mm ²)	Same as above.	N/A
3.3.4	Terminals for permanent wiring, including protective earthing terminals, are suitable for Canadian/US wire gauge sizes, are	Same as above.	N/A
	- rated 125 per cent of the equipment rating, and	Same as above.	N/A
	- are specially marked when specified (1.7.7)	Same as above.	N/A
3.3.5	Revise first column of Table 3E to "Smaller of the RATED CURRENT of the equipment or the PROTECTIVE CURRENT RATING of the circuit under consideration"	The equipment is not permanently connected or provided with a non-detachable power supply cord.	N/A
3.4.2	Motor control devices are provided for cord-connected equipment with a motor if the equipment is rated more than 12 A,	Not applicable.	N/A
	- or if the motor has a nominal voltage rating greater than 120 V	Same as above.	N/A
	- or is rated more than 1/3 hp (locked rotor current over 43 A)	Same as above.	N/A
3.4.8	Vertically-mounted disconnect switches and circuit breakers have the "on" position indicated by the handle in the up position	No switch or the switch is not a disconnect device.	N/A
3.4.11	For computer room applications, equipment with battery systems capable of supplying 750 VA for five minutes have a battery disconnect means that may be connected to the computer room remote power-off circuit	Not applicable.	N/A
4.3.12	The maximum quantity of flammable liquid stored in equipment complies with NFPA 30	No flammable liquids in this unit.	N/A
4.3.13.5.1	Equipment with lasers meets the U.S. Code of Federal Regulations 21 CFR 1040 (and the Canadian Radiation Emitting Devices Act, REDR C1370).	No lasers provided.	N/A

IEC 60950-1			
Clause	Requirement + Test	Result - Remark	Verdict
National Difference of IEC 60950-1:2005 (Second Edition) + Am 1: 2009 + Am 2: 2013			

4.7	For computer room applications, automated information storage systems with combustible media greater than 0.76 m ³ (27 cu ft) have a provision for connection of either automatic sprinklers or a gaseous agent extinguishing system with an extended discharge	Not applicable.	N/A
4.7.3.1	For computer room applications, enclosures with combustible material measuring greater than 0.9m ² (10 sq ft) or a single dimension greater than 1.8 m (6 ft) have a flame spread rating of 50 or less	Not applicable.	N/A
	For other applications, enclosures with the same dimensions require a flame spread rating of 200 or less	Same as above.	N/A
4.7.3.1	Non-metallic enclosures of equipment for use in spaces used for environmental air (plenums) are required to comply with UL 2043	Not applicable.	N/A
Annex H	Equipment that produces ionizing radiation complies with U.S. Code of Federal Regulations, 21 CFR 1020 (and the Canadian Radiation Emitting Devices Act, REDR C1370)	No ionizing radiation provided.	N/A

Other National Differences			
1.5.1	<p>Some components and materials associated with the risk of fire, electric shock, or personal injury have component or material ratings in accordance with the applicable national (Canadian and/or U.S.) component or material standard requirements.</p> <p>These components include: attachment plugs, battery backup systems, battery packs, cathode ray tubes, circuit breakers, communication circuit accessories, connectors (used for current interruption of non-LPS circuits), cord sets and power supply cords, direct plug-in equipment, electrochemical capacitor modules (energy storage modules with ultracapacitors), enclosures (outdoor), flexible cords and cables, fuses (branch circuit), fuseholders, ground-fault current interrupters, industrial control equipment, insulating tape, interconnecting cables, lampholders, limit controls, printed wiring, protectors for communications circuits, receptacles, solid state controls, supplementary protectors, switches (including interlock switches), thermal cut-offs, thermostats, (multi-layer) transformer winding wire, surge protective devices, tubing, vehicle battery adapters, wire connectors, and wire and cables</p>	Complied check.	P

IEC 60950-1			
Clause	Requirement + Test	Result - Remark	Verdict
National Difference of IEC 60950-1:2005 (Second Edition) + Am 1: 2009 + Am 2: 2013			
1.6.1.2	A circuit for connection to the DC Mains Supply is classified as a SELV Circuit, TNV-2 Circuit or Hazardous Voltage Circuit depending on the maximum operating voltage of the supply	Mains from AC source only.	N/A
	This maximum operating voltage includes consideration of the battery charging "float voltage" associated with the intended supply system, regardless of the marked power rating of the equipment	Same as above.	N/A
2.3.1	For TNV-2 and TNV-3 circuits with other than ringing signals and with voltages exceeding 42.4 V _{peak} or 60 Vd.c., the maximum acceptable current through a 2000 ohm resistor (or greater) connected across the voltage source with other loads disconnected is 7.1 mA peak or 30 mA d.c. under normal operating conditions	No TNV circuits provided.	N/A
2.3.2.1	In the event of a single fault between TNV and SELV circuits, the limits of 2.2.3 apply to SELV Circuits and accessible conductive parts	No TNV circuits provided.	N/A
2.6.2	Equipment with functional earthing marked with the functional earthing symbol (IEC 60417-6092)	Class II equipment.	N/A
2.6.3.4	Protective bonding conductors of non-standard protective bonding constructions (e.g., printed circuit traces) may be subjected to the additional limited short circuit test conditions specified	Class II equipment.	N/A
4.2.8.1	Enclosures around CRTs with a face diameter of 160 mm or more reduce the risk of injury due to the implosion of the CRT	No cathode ray tubes provided.	N/A
4.3.2	Equipment with handles complies with special loading tests	No handles or manual controls provided.	N/A
4.3.8	Battery packs for both portable and stationary applications comply with special component requirements	No batteries provided.	N/A
5.1.8.3	Equipment intended to receive telecommunication ringing signals comply with a special touch current measurement tests	No TNV circuit provided.	N/A
5.3.7	Internal (e.g., card cage) SELV circuit connectors and printed wiring board connectors that are accessible to the operator and that deliver power are overloaded	Not applicable	N/A
	During abnormal operating testing, if a circuit is interrupted by the opening of a component, the test is repeated twice (three tests total) using new components as necessary	Same as above.	N/A
6.4	Equipment intended for connection to telecommunication network outside plant cable is	No TNV circuit provided.	N/A

IEC 60950-1			
Clause	Requirement + Test	Result - Remark	Verdict
National Difference of IEC 60950-1:2005 (Second Edition) + Am 1: 2009 + Am 2: 2013			

	protected against overvoltage from power line crosses in accordance with 6.4 and Annex NAC		
Annex EE	Articulated accessibility probe (Fig EE.3) is used for assessing accessibility to document/media shredders instead of the Figure 2A test finger	Not applicable	N/A
Annex M.2	Continuous ringing signals up to 16 mA only are permitted if the equipment is subjected to special installation and performance restrictions	No ringing signals provided.	N/A
Annex NAD	Equipment connected to a telecommunication and cable distribution networks and supplied with an earphone intended to be held against, or in the ear comply with special acoustic pressure requirements	Not applicable	N/A

ATTACHMENT TO TEST REPORT IEC 60950-1 CANADA NATIONAL DIFFERENCES	
Information technology equipment – Safety – Part 1: General requirements	
Differences according to	CAN/CSA-C22.2 No. 60950-1-07
Attachment Form No.....	60950-1 Ed2-Am2_NatDiff
Attachment Originator	CSA
Master Attachment	Date 2014-09-13
Copyright © 2014 IEC System for Conformity Testing and Certification of Electrical Equipment (IECEE), Geneva, Switzerland. All rights reserved.	

Special national conditions			
	The following is a summary of the key national differences based on national regulatory requirements, such as the Canadian Electrical Code (CEC) Part I and the Canadian Building Code, which are referenced in legislation and which form the basis for the rules and practices followed in electrical and building installations	Complied check.	P
1.1.1	All equipment is to be designed to allow installation in accordance with the National Electrical Code (NEC), ANSI/NFPA 70, the Canadian Electrical Code (CEC), Part I, CAN/CSA C22.1, and when applicable, the National Electrical Safety Code, IEEE C2. Also, unless marked or otherwise identified, installation is allowed per the Standard for the Protection of Electronic Computer/Data Processing Equipment, ANSI/NFPA 75.	Complied check.	P
1.1.2	Baby monitors are required to comply with ASTM	Not applicable.	N/A

ATTACHMENT

IEC 60950-1			
Clause	Requirement + Test	Result - Remark	Verdict
National Difference of IEC 60950-1:2005 (Second Edition) + Am 1: 2009 + Am 2: 2013			
	F2951, Consumer Safety Specification for Baby Monitors		
1.4.14	For Pluggable Equipment Type A, the protection in the installation is assumed to be 20A.	Complied check.	P
1.5.5	For lengths exceeding 3.05 m, external interconnecting flexible cord and cable assemblies are required to be a suitable cable type (e.g., DP, CL2) specified in the CEC/NEC.	Complied check.	P
	For lengths 3.05 m or less, external interconnecting flexible cord and cable assemblies that are not types specified in the CEC are required to have special construction features and identification markings.	Complied check.	P
1.7.1	Equipment for use on a.c. mains supply systems with a neutral and more than one phase conductor (e.g. 120/240 V, 3-wire) require a special marking format for electrical ratings.	Not applicable.	N/A
	A voltage rating that exceeds an attachment plug cap rating is only permitted if it does not exceed the extreme operating conditions in Table 2 of CAN/CSA C22.2 No. 235, and if it is part of a range that extends into the Table 2 "Normal Operating Conditions." Likewise, a voltage rating shall not be lower than the specified "Normal Operating Conditions," unless it is part of a range that extends into the "Normal Operating Conditions."	Same as above.	N/A
1.7.7	Wiring terminals intended to supply Class 2 outputs in accordance with CEC Part 1 or NEC shall be marked with the voltage rating and "Class 2" or equivalent. Marking shall be located adjacent to the terminals and shall be visible during wiring.	Not applicable.	N/A
2.5	Where a fuse is used to provide Class 2, Limited Power Source, or TNV current limiting, it shall not be operator-accessible unless it is not interchangeable.	Not applicable.	N/A
2.6	Equipment with isolated ground (earthing) receptacles is required to comply with NEC 250.146(D) and CEC 10-112 and 10-906(8).	Class II equipment.	N/A
2.7.1	Suitable NEC/CEC branch circuit protection rated at the maximum circuit rating is required for all standard supply outlets and receptacles (such as supplied in power distribution units) if the supply branch circuit protection is not suitable.	Complied check.	P
	Power distribution transformers distributing power at 100 volts or more, and rated 10 kVA or more, require special transformer overcurrent protection.	Complied check.	P

ATTACHMENT

IEC 60950-1			
Clause	Requirement + Test	Result - Remark	Verdict
National Difference of IEC 60950-1:2005 (Second Edition) + Am 1: 2009 + Am 2: 2013			
3.2	Wiring methods (terminals, leads, etc.) used for the connection of the equipment to the mains shall be in accordance with the NEC/CEC.	Direct plug-in equipment.	N/A
3.2.1	Power supply cords are required to have attachment plugs rated not less than 125 percent of the rated current of the equipment.	Same as above.	N/A
3.2.1.2	Equipment connected to a centralized d.c. power system, and having one pole of the DC mains input terminal connected to the main protective earthing terminal in the equipment, is required to comply with special earthing, wiring, marking and installation instruction requirements.	Mains from AC source only.	N/A
3.2.3	Permanent connection of equipment to the mains supply by a power supply cord is not permitted, except for certain equipment, such as ATMs.	The equipment is not permanently connected.	N/A
3.2.5	Power supply cords are required to be no longer than 4.5 m in length.	Direct plug-in equipment.	N/A
	Minimum cord length is required to be 1.5 m, with certain constructions such as external power supplies allowed to consider both input and output cord lengths into the requirement.	Same as above.	N/A
	Flexible power supply cords are required to be compatible with Article 400 of the NEC, and Tables 11 and 12 of the CEC.	Same as above.	N/A
3.2.9	Permanently connected equipment is required to have a suitable wiring compartment and wire bending space.	Direct plug-in equipment	N/A
3.3	Wiring terminals and associated spacings for field wiring connections shall comply with CSA C22.2 No. 0.	The equipment is not permanently connected or provided with a non-detachable power supply cord.	N/A
3.3.3	Wire binding screws are not permitted to attach conductors larger than 10 AWG (5.3 mm ²).	Same as above.	N/A
3.3.4	Terminals for permanent wiring, including protective earthing terminals, are required to be suitable for Canadian/US wire gauge sizes, rated 125 percent of the equipment rating, and be specially marked when specified (1.7.7).	Same as above.	N/A
3.3.5	First column of Table 3E revised to require "Smaller of the RATED CURRENT of the equipment or the PROTECTIVE CURRENT RATING of the circuit under consideration."	Same as above.	N/A
3.4.2	Motor control devices are required for cord-connected equipment with a motor if the equipment is rated more than 12 A, or if the motor has a nominal voltage rating greater than 120 V, or	Not applicable.	N/A

ATTACHMENT

IEC 60950-1			
Clause	Requirement + Test	Result - Remark	Verdict
National Difference of IEC 60950-1:2005 (Second Edition) + Am 1: 2009 + Am 2: 2013			

	is rated more than 1/3 hp (locked rotor current over 43 A).		
3.4.8	Vertically-mounted disconnect switches and circuit breakers are required to have the "on" position indicated by the handle in the up position.	No switch or the switch is not a disconnect device.	N/A
3.4.11	For computer room applications, equipment with battery systems capable of supplying 750 VA for five minutes are required to have a battery disconnect means that may be connected to the computer room remote power-off circuit.	Not applicable.	N/A
4.3.12	The maximum quantity of flammable liquid stored in equipment is required to comply with NFPA 30.	No flammable liquids in this unit.	N/A
4.3.13.5.1	Equipment with lasers is required to meet the Canadian Radiation Emitting Devices Act, REDR C1370 and/or Code of Federal Regulations 21 CFR 1040, as applicable.	No lasers provided.	N/A
4.7	For computer room applications, automated information storage systems with combustible media greater than 0.76 m ³ (27 cu ft) are required to have a provision for connection of either automatic sprinklers or a gaseous agent extinguishing system with an extended discharge.	Not applicable.	N/A
4.7.3.1	For computer room applications, enclosures with combustible material measuring greater than 0.9 m ² (10 sq ft) or a single dimension greater than 1.8 m (6 ft) are required to have a flame spread rating of 50 or less. For other applications, enclosures with the same dimensions require a flame spread rating of 200 or less.	Not applicable.	N/A
Annex H	Equipment that produces ionizing radiation is required to comply with the Canadian Radiation Emitting Devices Act, REDR C1370 and/or Code of Federal Regulations, 21 CFR 1020, as applicable.	No ionizing radiation provided.	N/A

	Other National Differences		
	The following key national differences are based on requirements other than national regulatory requirements	Complied check.	P
1.5.1	Some components and materials associated with the risk of fire, electric shock, or personal injury are required to have component or material ratings in accordance with the applicable national (Canadian and/or U.S.) component or material standard requirements. These components include: attachment plugs, battery packs (rechargeable type, used with transportable equipment), cathode ray tubes, circuit breakers, communication circuit	Complied check.	P

ATTACHMENT

IEC 60950-1			
Clause	Requirement + Test	Result - Remark	Verdict
National Difference of IEC 60950-1:2005 (Second Edition) + Am 1: 2009 + Am 2: 2013			

	accessories, connectors (used for current interruption of non-LPS circuits), cord sets and power supply cords, direct plug-in equipment, enclosures (outdoor), flexible cords and cables, fuses (branch circuit), fuseholders, ground-fault current interrupters, industrial control equipment, insulating tape, interconnecting cables, lampholders, limit controls, printed wiring, protectors for communications circuits, receptacles, solid state controls, supplementary protectors, switches (including interlock switches), thermal cutoffs, thermostats, (multi-layer) transformer winding wire, transient voltage surge suppressors, tubing, wire connectors, and wire and cables.		
1.6.1.2	A circuit for connection to the DC Mains Supply is classified as a SELV Circuit, TNV-2 Circuit or Hazardous Voltage Circuit depending on the maximum operating voltage of the supply. This maximum operating voltage shall include consideration of the battery charging "float voltage" associated with the intended supply system, regardless of the marked power rating of the equipment.	Mains from AC source only.	N/A
2.3.1	For TNV-2 and TNV-3 circuits with other than ringing signals and with voltages exceeding 42.4 V _{peak} or 60 V _{d.c.} , the maximum acceptable current through a 2000 ohm resistor (or greater) connected across the voltage source with other loads disconnected is 7.1 mA peak or 30 mA d.c. under normal operating conditions.	No TNV circuits provided.	N/A
2.3.2.1	In the event of a single fault between TNV and SELV circuits, the limits of 2.2.3 apply to SELV Circuits and accessible conductive parts.	No TNV circuits provided.	N/A
2.6.2	Equipment with functional earthing is required to be marked with the functional earthing symbol (IEC 60417-6092)	Class II equipment.	N/A
2.6.3.4	Protective bonding conductors of non-standard protective bonding constructions (e.g., printed circuit traces) may be subjected to the additional limited short circuit test conditions specified.	Class II equipment.	N/A
4.2.8.1	Enclosures around CRTs with a face diameter of 160 mm or more are required to reduce the risk of injury due to the implosion of the CRT.	No cathode ray tubes provided.	N/A
4.3.2	Equipment with handles is required to comply with special loading tests.	No handles or manual controls provided.	N/A
4.3.8	Battery packs for both portable and stationary applications are required to comply with special	No batteries provided.	N/A

ATTACHMENT

IEC 60950-1			
Clause	Requirement + Test	Result - Remark	Verdict
National Difference of IEC 60950-1:2005 (Second Edition) + Am 1: 2009 + Am 2: 2013			
	component requirements.		
5.1.8.3	Equipment intended to receive telecommunication ringing signals is required to comply with a special touch current measurement tests.	No TNV circuit provided.	N/A
5.3.7	Internal (e.g., card cage) SELV circuit connectors and printed wiring board connectors that are accessible to the operator and that deliver power are to be overloaded.	Not applicable	N/A
	During abnormal operating testing, if a circuit is interrupted by the opening of a component, the test shall be repeated twice (three tests total) using new components as necessary.	Same as above.	N/A
6.4	Equipment intended for connection to telecommunication network outside plant cable is required to be protected against overvoltage from power line crosses in accordance with 6.4 and Annex NAC.	No TNV circuit provided.	N/A
Annex EE	Articulated accessibility probe (Fig EE.3) required for assessing accessibility to document/media shredders instead of the Figure 2A test finger.	Not applicable	N/A
Annex M.2	Continuous ringing signals up to 16 mA only are permitted if the equipment is subjected to special installation and performance restrictions.	No ringing signals provided.	N/A
Annex NAD	Equipment connected to a telecommunication and cable distribution networks and supplied with an earphone intended to be held against, or in the ear is required to comply with special acoustic pressure requirements.	Not applicable	N/A

IEC 60950-1			
Clause	Requirement + Test	Result - Remark	Verdict
National Difference of IEC 60950-1:2005 (Second Edition) + Am 1: 2009			

ATTACHMENT TO TEST REPORT IEC 60950-1 FINLAND NATIONAL DIFFERENCES Information technology equipment – Safety – Part 1: General requirements	
Differences according to	EN 60950-1:2006/A11:2009/A1:2010
Attachment Form No.....	FI_ND_IEC60950_1C
Attachment Originator	SGS Fimko Ltd
Master Attachment	Date (2010-04)
Copyright © 2010 IEC System for Conformity Testing and Certification of Electrical Equipment (IECEE), Geneva, Switzerland. All rights reserved.	

EN 60950-1:2006/A11:2009/A1:2010/A12:2011 – CENELEC COMMON MODIFICATIONS
--

General	See also Group Differences (EN 60950-1:2006/A11/A1)		
1.5.7.1	In Finland resistors bridging BASIC INSULATION in CLASS I PLUGGABLE EQUIPMENT TYPE A must comply with the requirements in 1.5.7.1. In addition when a single resistor is used, the resistor must withstand the resistor test in 1.5.7.2.	No such Resistors provided.	N/A
1.5.9.4	In Finland , the third dashed sentence is applicable only to equipment as defined in 6.1.2.2 of this annex.	No such VDR provided.	N/A
1.7.2.1	In Finland , CLASS I PLUGGABLE EQUIPMENT TYPE A intended for connection to other equipment or a network shall, if safety relies on connection to protective earth or if surge suppressors are connected between the network terminals and accessible parts, have a marking stating that the equipment must be connected to an earthed mains socket-outlet. The marking text in in Finland shall be as follows: "Laite on liitettävä suojakoskettimilla varustettuun pistorasiaan"	Class II equipment.	N/A
2.3.2	In Finland , there are additional requirements for the insulation. See 6.1.2.1 and 6.1.2.2 of this annex.	No TNV circuits provided.	N/A
2.10.5.13	In Finland , there are additional requirements for the insulation, see 6.1.2.1 and 6.1.2.2 of this annex.	No TNV circuits provided.	N/A
5.1.7.1	In Finland , TOUCH CURRENT measurement results exceeding 3,5 mA r.m.s. are permitted only for the following equipment:	Touch current does not exceed 3.5mA	N/A

IEC 60950-1			
Clause	Requirement + Test	Result - Remark	Verdict
National Difference of IEC 60950-1:2005 (Second Edition) + Am 1: 2009			

	<ul style="list-style-type: none"> • STATIONARY PLUGGABLE EQUIPMENT TYPE A that <ul style="list-style-type: none"> - is intended to be used in a RESTRICTED ACCESS LOCATION where equipotential bonding has been applied, for example, in a telecommunication centre; and - has provision for a permanently connected PROTECTIVE EARTHING CONDUCTOR; and - is provided with instructions for the installation of that conductor by a SERVICE PERSON; • STATIONARY PLUGGABLE EQUIPMENT TYPE B; • STATIONARY PERMANENTLY CONNECTED EQUIPMENT. 		
6.1.2.1 (A1:2010)	<p>In Finland, add the following text between the first and second paragraph of the compliance clause:</p> <p>If this insulation is solid, including insulation forming part of a component, it shall at least consist of either</p> <ul style="list-style-type: none"> - two layers of thin sheet material, each of which shall pass the electric strength test below, or - one layer having a distance through insulation of at least 0,4 mm, which shall pass the electric strength test below. <p>Alternatively for components, there is no distance through insulation requirement for the insulation consisting of an insulating compound completely filling the casing, so that CLEARANCES and CREEPAGE DISTANCES do not exist, if the component passes the electric strength test in accordance with the compliance clause below and in addition</p> <ul style="list-style-type: none"> - passes the tests and inspection criteria of 2.10.11 with an electric strength test of 1,5 kV multiplied by 1,6 (the electric strength test of 2.10.10 shall be performed using 1,5 kV), and - is subject to ROUTINE TESTING for electric strength during manufacturing, using a test voltage of 1,5 kV. <p>It is permitted to bridge this insulation with an optocoupler complying with 2.10.5.4 b).</p> <p>It is permitted to bridge this insulation with a capacitor complying with EN 60384-14:2005, subclass Y2.</p> <p>A capacitor classified Y3 according to EN 60384-14:2005, may bridge this insulation under the following conditions:</p> <ul style="list-style-type: none"> - the insulation requirements are satisfied by 	No TNV circuits provided.	N/A

IEC 60950-1			
Clause	Requirement + Test	Result - Remark	Verdict
National Difference of IEC 60950-1:2005 (Second Edition) + Am 1: 2009			
	having a capacitor classified Y3 as defined by EN 60384-14:2005 which in addition to the Y3 testing, is tested with an impulse test of 2,5 kV defined in EN 60950-1:2006, 6.2.2.1; - the additional testing shall be performed on all the test specimens as described in EN 60384-14:2005; - the impulse test of 2,5 kV is to be performed before the endurance test in EN 60384-14:2005, in the sequence of tests as described in EN 60384-14:2005.		
6.1.2.2	In Finland , the exclusions are applicable for PERMANENTLY CONNECTED EQUIPMENT, PLUGGABLE EQUIPMENT TYPE B and equipment intended to be used in a RESTRICTED ACCESS LOCATION where equipotential bonding has been applied, e.g. in a telecommunication centre, and which has provision for a permanently connected PROTECTIVE EARTHING CONDUCTOR and is provided with instructions for the installation of that conductor by a SERVICE PERSON.	No TNV circuits provided.	N/A
7.2	In Finland , for requirements see 6.1.2.1 and 6.1.2.2 of this annex. The term TELECOMMUNICATION NETWORK in 6.1.2 being replaced by the term CABLE DISTRIBUTION SYSTEM.	No cable distribution systems	N/A

ATTACHMENT TO TEST REPORT IEC 60950-1

Germany NATIONAL DIFFERENCES

Information technology equipment – Safety –
Part 1: General requirements

Differences according to: VDE 0805-1:2011-01

Annex ZC, cl. 1.7.2.1	According to GPSG, section 2, clause 4: If certain rules on the use, supplementation or maintenance of an item of technical work equipment or ready-to-use commodity must be observed in order to guarantee safety and health, instructions for use in German must be supplied when it is brought into circulation.	Not applicable.	N/A
-----------------------	--	-----------------	-----

ATTACHMENT TO TEST REPORT IEC 60950-1

Republic of Korea NATIONAL DIFFERENCES

IEC 60950-1			
Clause	Requirement + Test	Result - Remark	Verdict
National Difference of IEC 60950-1:2005 (Second Edition) + Am 1: 2009			

Information technology equipment – Safety – Part 1: General requirements			
Differences according to		K 60950-1 Part 1	

1.5.101	Plugs for the connection of the apparatus to the supply mains shall comply with the Korean requirement (KSC 8305).	Not applicable.	N/A
8	EMC The apparatus shall comply with the relevant CISPR standards	The requirements have to be checked during national approval.	N/A

ATTACHMENT TO TEST REPORT IEC 60950-1 Slovenia NATIONAL DIFFERENCES Information technology equipment – Safety – Part 1: General requirements			
Differences according to		SIST EN 60950:2006+A1:2010	

N/A	N/A	N/A	N/A
-----	-----	-----	-----

ATTACHMENT TO TEST REPORT IEC 60950-1 ISRAEL NATIONAL DIFFERENCES Information technology equipment – Safety – Part 1: General requirements			
Differences according to		SI 60950 Part 1	

1.1.1	Replace the text of Note 3 as follows: The requirements of Israel Standard SI 60065 may also be used to meet safety requirements for multimedia equipment. See IEC Guide 112, Guide on the safety of multimedia equipment.	Not applicable.	N/A
1.6	The clause is applicable with the following addition:	Same as above.	N/A
1.6.1	Add following note: In Israel, this clause is applicable subject to the Electricity Law, 1954, its regulations and revisions.	Same as above.	N/A
1.7	The clause is applicable with the following additions: Sub clause 1.7.201 shall be added at the beginning of the clause as follows:	Same as above.	N/A

IEC 60950-1			
Clause	Requirement + Test	Result - Remark	Verdict
National Difference of IEC 60950-1:2005 (Second Edition) + Am 1: 2009			

1.7.201	<p>Marking in the Hebrew language</p> <p>The marking in the Hebrew language shall be in accordance with the Consumer Protection Order (Marking of goods), 1983.</p> <p>In addition to the marking required by clause 1.7.1, the following details shall be marked in the Hebrew language.</p> <p>The details shall be marked on the apparatus or on its package, or on a label properly attached to the apparatus or on the package, by bonding or sewing, in a manner that the label cannot be easily removed.</p> <ol style="list-style-type: none"> 1. Name of the apparatus and its commercial designation; 2. Manufacturer's name and address. If the apparatus is imported, the importer's name and address; 3. Manufacturer's registered trademark, if any; 4. Name of the model and serial number, if any; 5. Country of manufacture. 	Same as above.	N/A
1.7.2.1	<p>The following shall be added to the clause:</p> <p>All the instructions and warnings related to safety shall also be written in the Hebrew language.</p>	Same as above.	N/A
2	The clause is applicable with the following additions:	Same as above.	—
2.9.4	<p>The following shall be added at the beginning of the clause:</p> <p>In Israel, according to the Electricity Law, 1954, and the Electricity Regulations (Earthing and means of protection against electricity of voltages up to 1,000V) 1991, seven means of protection against electrocution are permitted, as follows:</p> <ol style="list-style-type: none"> 1) TN-S - Network system earthing; TN-C-S Network system earthing; 2) TT - Network system earthing; 3) IT - Network Insulation Terre; 4) Isolated transformer; 5) Safety extra low voltage (SELV or ELV); 6) Residual current circuit breaker (30 mA = I); 7) Reinforced insulation; Double insulation (class II) 	Same as above.	—
2.201	<p>Prevention of electromagnetic interference</p> <p>- Prior to carrying out the tests in accordance with the clauses of this Standard, the compliance of the apparatus with the relevant requirements specified</p>	Same as above.	—

ATTACHMENT

IEC 60950-1			
Clause	Requirement + Test	Result - Remark	Verdict
National Difference of IEC 60950-1:2005 (Second Edition) + Am 1: 2009			
	<p>in the appropriate part of the Standard series, SI 961, shall be checked.</p> <p>The apparatus shall meet the requirements in the appropriate part of the Standard series, SI 961.</p> <p>- If there are components in the apparatus for the prevention of electromagnetic interference, these components shall not reduce the safety level of the apparatus as required by this Standard.</p>		
3	The clause is applicable with the following additions:	Same as above.	N/A
3.2.1.1	<p>Connection to an a.c. mains supply After the note, the following note shall be added:</p> <p>Note:</p> <p>In Israel, the feed plug shall comply with the requirements of Israel Standard SI 32 Part 1.1.</p>	Same as above.	N/A
3.2.1.2	<p>Connection to a d.c. mains supply At the end of the first paragraph, the following note shall be added:</p> <p>Note:</p> <p>At the time of issue of this Standard, there is no Israel Standard for connection accessories to d.c.</p>	Same as above.	N/A
Annex P	<p>Normative references</p> <p>(List of relevant Israel Standards that have been inserted in place of some of the International Standards)</p>	Same as above.	N/A

IEC 60950-1			
Clause	Requirement + Test	Result - Remark	Verdict

National Difference of IEC 60950-1:2005 (Second Edition)

**ATTACHMENT TO TEST REPORT IEC 60950-1
AUSTRALIA NATIONAL DIFFERENCES
Information technology equipment – Safety –
Part 1: General requirements**

Differences according to: AS/NZS 60950.1:2011

1.2	Insert the following between 'person, service' and 'range, rated frequency': POTENTIAL IGNITION SOURCE 1.2.12	Not applicable.	N/A																	
1.2.12.201	Insert a new Clause 1.2.12.201 after Clause 1.2.12.15 as follows: 1.2.12.201 POTENTIAL IGNITION SOURCE Possible fault which can start a fire if the open-circuit voltage measured across an interruption or faulty contact exceeds a value of 50 V (peak) a.c. or d.c. and the product of the peak value of this voltage and the measured r.m.s. current under normal operating conditions exceeds 15 VA. Such a faulty contact or interruption in an electrical connection includes those which may occur in CONDUCTIVE PATTERNS on PRINTED BOARDS. NOTE 201 An electronic protection circuit may be used to prevent such a fault from becoming a POTENTIAL IGNITION SOURCE. NOTE 202 This definition is from AS/NZS 60065:2003.	Not applicable.	N/A																	
1.5.1	1. Add the following to the end of the first paragraph: 'or the relevant Australian/New Zealand Standard.' 2. In NOTE 1, add the following after the word 'standard': 'or an Australian/New Zealand Standard'	Added.	P																	
1.5.2	Add the following to the end of the first and third dash items: 'or the relevant Australian/New Zealand Standard'	Added.	P																	
3.2.5.1	Modify Table 3B as follows: 1. Delete the first four rows and replace with the following: <table border="1" data-bbox="354 1640 889 1862"> <thead> <tr> <th rowspan="2">RATED CURRENT of equipment A</th> <th colspan="2">Minimum conductor sizes</th> </tr> <tr> <th>Nominal cross-sectional area mm²</th> <th>AWG or kcmil [cross-sectional area in mm²] see Note 2</th> </tr> </thead> <tbody> <tr> <td>Over 0.2 up to and including 3</td> <td>0.5^a</td> <td>18 [0.6]</td> </tr> <tr> <td>Over 3 up to and including 7.5</td> <td>0.75</td> <td>16 [1.3]</td> </tr> <tr> <td>Over 7.5 up to and including 10</td> <td>(0.75)^b</td> <td>16 [1.3]</td> </tr> <tr> <td>Over 10 up to and including 15</td> <td>(1.0)^c</td> <td>14 [2]</td> </tr> </tbody> </table> 2. Delete NOTE 1. 3. Delete Footnote ^a and replace with the	RATED CURRENT of equipment A	Minimum conductor sizes		Nominal cross-sectional area mm ²	AWG or kcmil [cross-sectional area in mm ²] see Note 2	Over 0.2 up to and including 3	0.5 ^a	18 [0.6]	Over 3 up to and including 7.5	0.75	16 [1.3]	Over 7.5 up to and including 10	(0.75) ^b	16 [1.3]	Over 10 up to and including 15	(1.0) ^c	14 [2]	Direct plug-in equipment.	N/A
RATED CURRENT of equipment A	Minimum conductor sizes																			
	Nominal cross-sectional area mm ²	AWG or kcmil [cross-sectional area in mm ²] see Note 2																		
Over 0.2 up to and including 3	0.5 ^a	18 [0.6]																		
Over 3 up to and including 7.5	0.75	16 [1.3]																		
Over 7.5 up to and including 10	(0.75) ^b	16 [1.3]																		
Over 10 up to and including 15	(1.0) ^c	14 [2]																		

IEC 60950-1			
Clause	Requirement + Test	Result - Remark	Verdict
National Difference of IEC 60950-1:2005 (Second Edition)			
	<p>following:</p> <p>a This nominal cross-sectional area is only allowed for Class II appliances if the length of the power supply cord, measured between the point where the cord, or cord guard, enters the appliance, and the entry to the plug does not exceed 2 m (0,5 mm² three-core supply flexible cords are not permitted; see AS/NZS 3191).</p>		
4.1.201	<p>Insert a new Clause 4.1.201 after Clause 4.1 as follows:</p> <p>4.1.201 Display devices used for television purposes</p> <p>Display devices which may be used for television purposes, with a mass of 7 kg or more, shall comply with the requirements for stability and mechanical hazards, including the additional stability requirements for television receivers, specified in AS/NZS 60065.</p>	Not applicable.	N/A
4.3.6	<p>Delete the third paragraph and replace with the following:</p> <p>Equipment with a plug portion, suitable for insertion into a 10 A 3-pin flatpin socket-outlet complying with AS/NZS 3112 shall comply with the requirements in AS/NZS 3112 for equipment with integral pins for insertion into socket-outlets.</p>	The main plug has been evaluated according to AS/NZS 3112: 2011 + A1: 2012 + 2013, Report No.: TP-14032 (TW14040234 and TW14040234(R1))	P
4.3.16.5	<p>Add the following to the end of the first paragraph: 'or AS/NZS 2211.1'</p>	Added.	
4.7	<p>Add the following new paragraph to the end of the clause: 'For alternate tests refer to Clause 4.7.201.'</p>	Added.	
4.7.201	<p>Insert a new Clause 4.7.201 after Clause 4.7.3.6 as follows: 4.7.201 Resistance to fire – Alternative tests</p>	Not applicable.	N/A
4.7.201.1	<p>4.7.201.1 General Parts of non-metallic material shall be resistant to ignition and spread of fire. This requirement does not apply to decorative trims, knobs and other parts unlikely to be ignited or to propagate flames from inside the apparatus, or the following: (a) Components that are contained in an enclosure having a flammability category of V-0 according to AS/NZS 60695.11.10 and having openings only for the connecting wires filling the openings completely, and for ventilation not exceeding 1mm in width regardless of length. (b) The following parts which would contribute negligible fuel to a fire: -small mechanical parts, the mass of which does not exceed 4g, such as mounting parts, gears, cams, belts and bearings; -</p>	Not applicable.	N/A

IEC 60950-1			
Clause	Requirement + Test	Result - Remark	Verdict
National Difference of IEC 60950-1:2005 (Second Edition)			
	<p>small electrical components, such as capacitors with a volume not exceeding 1,750 mm³, integrated circuits, transistors and optocoupler packages, if these components are mounted on material of flammability category V-1, or better, according to AS/NZS 60695.11.10. NOTE In considering how to minimize propagation of fire and what 'small parts' are, account should be taken of the cumulative effect of small parts adjacent to each other for the possible effect of propagating the fire from one part to another. Compliance shall be checked by the tests of 4.7.201.2, 4.7.201.3, 4.7.201.4 and 4.7.201.5. For the base material of printed boards, compliance shall be checked by the test of 4.7.201.5. The tests shall be carried out on parts of non-metallic material which have been removed from the apparatus. When the glow-wire test is carried out, the parts shall be placed in the same orientation as they would be in normal use. These tests are not carried out on internal wiring.</p>		
4.7.201.2	<p>Parts of non-metallic material shall be subject to the glow-wire test of AS/NZS 60695.2.11 which shall be carried out at 550 °C.</p> <p>Parts for which the glow-wire test cannot be carried out, such as those made of soft or foamy material, shall meet the requirements specified in ISO 9772 for category FH-3 material. The glow-wire test shall be not carried out on parts of material classified at least FH-3 according to ISO 9772 provided that the sample tested was not thicker than the relevant part.</p>	Not applicable.	N/A
4.7.201.3	<p>4.7.201.3 Testing of insulating materials Parts of insulating material supporting POTENTIAL IGNITION SOURCES shall be subject to the glow-wire test of AS/NZS 60695.2.11 which shall be carried out at 750 °C.</p> <p>The test shall be also carried out on other parts of insulating material which are within a distance of 3 mm of the connection.</p> <p>NOTE Contacts in components such as switch contacts are considered to be connections.</p> <p>For parts which withstand the glow-wire test but produce a flame, other parts above the connection within the envelope of a vertical cylinder having a diameter of 20 mm and a height of 50 mm shall be subjected to the needle-flame test. However, parts shielded by a barrier which meets the needle-flame test shall not be tested.</p> <p>The needle-flame test shall be made in accordance with AS/NZS 60695.11.5 with the following</p>	Not applicable.	N/A

IEC 60950-1			
Clause	Requirement + Test	Result - Remark	Verdict

National Difference of IEC 60950-1:2005 (Second Edition)

	<p>modifications:</p> <table border="1"> <thead> <tr> <th>Clause of AS/NZS 60695.11.5</th> <th>Change</th> </tr> </thead> <tbody> <tr> <td>9 Test procedure</td> <td></td> </tr> <tr> <td>9.2 Application of needle flame</td> <td> <p>Replace the first paragraph with:</p> <p>The specimen shall be arranged so that the flame can be applied to a vertical or horizontal edge as shown in the examples of figure 1. If possible the flame shall be applied at least 10 mm from a corner</p> <p>Replace the second paragraph with:</p> <p>The duration of application of the test flame shall be 30 s ± 1 s</p> </td> </tr> <tr> <td>9.3 Number of test specimens</td> <td> <p>Replace with:</p> <p>The test shall be made on one specimen. If the specimen does not withstand the test, the test may be repeated on two further specimens, both of which shall withstand the test.</p> </td> </tr> <tr> <td>11 Evaluation of test results</td> <td> <p>Replace with:</p> <p>The duration of burning (t₁) shall not exceed 30 s. However, for printed circuit boards, t₁ shall not exceed 15 s.</p> </td> </tr> </tbody> </table> <p>The needle-flame test shall not be carried out on parts of material classified as V-0 or V-1 according to AS/NZS 60695.11.10, provided that the sample tested was not thicker than the relevant part.</p>	Clause of AS/NZS 60695.11.5	Change	9 Test procedure		9.2 Application of needle flame	<p>Replace the first paragraph with:</p> <p>The specimen shall be arranged so that the flame can be applied to a vertical or horizontal edge as shown in the examples of figure 1. If possible the flame shall be applied at least 10 mm from a corner</p> <p>Replace the second paragraph with:</p> <p>The duration of application of the test flame shall be 30 s ± 1 s</p>	9.3 Number of test specimens	<p>Replace with:</p> <p>The test shall be made on one specimen. If the specimen does not withstand the test, the test may be repeated on two further specimens, both of which shall withstand the test.</p>	11 Evaluation of test results	<p>Replace with:</p> <p>The duration of burning (t₁) shall not exceed 30 s. However, for printed circuit boards, t₁ shall not exceed 15 s.</p>		
Clause of AS/NZS 60695.11.5	Change												
9 Test procedure													
9.2 Application of needle flame	<p>Replace the first paragraph with:</p> <p>The specimen shall be arranged so that the flame can be applied to a vertical or horizontal edge as shown in the examples of figure 1. If possible the flame shall be applied at least 10 mm from a corner</p> <p>Replace the second paragraph with:</p> <p>The duration of application of the test flame shall be 30 s ± 1 s</p>												
9.3 Number of test specimens	<p>Replace with:</p> <p>The test shall be made on one specimen. If the specimen does not withstand the test, the test may be repeated on two further specimens, both of which shall withstand the test.</p>												
11 Evaluation of test results	<p>Replace with:</p> <p>The duration of burning (t₁) shall not exceed 30 s. However, for printed circuit boards, t₁ shall not exceed 15 s.</p>												
4.7.201.4	<p>4.7.201.4 Testing in the event of non-extinguishing material If parts, other than enclosures, do not withstand the glow wire tests of 4.7.201.3, by failure to extinguish within 30 s after the removal of the glowwire tip, the needle-flame test detailed in 4.7.201.3 shall be made on all parts of non-metallic material which are within a distance of 50 mm or which are likely to be impinged upon by flame during the tests of 4.7.201.3. Parts shielded by a separate barrier which meets the needle-flame test need not be tested. NOTE 1 If the enclosure does not withstand the glow-wire test the equipment is considered to have failed to meet the requirements of Clause 4.7.201 without the need for consequential testing. NOTE 2 If other parts do not withstand the glow-wire test due to ignition of the tissue paper and if this indicates that burning or glowing particles can fall onto an external surface underneath the equipment, the equipment is considered to have failed to meet the requirements of Clause 4.7.201 without the need for consequential testing. NOTE 3 Parts likely to be impinged upon by the flame are considered to be those within the envelope of a vertical cylinder having a radius of 10 mm and a height equal to the height of the flame, positioned above the point of the material supporting, in contact with, or in close proximity to, connections.</p>	Not applicable.	N/A										
4.7.201.5	<p>4.7.201.5 Testing of printed boards The base material of printed boards shall be</p>	Not applicable.	N/A										

IEC 60950-1			
Clause	Requirement + Test	Result - Remark	Verdict
National Difference of IEC 60950-1:2005 (Second Edition)			
	<p>subjected to the needle-flame test of Clause 4.7.201.3. The flame shall be applied to the edge of the board where the heat sink effect is lowest when the board is positioned as in normal use.</p> <p>The flame shall not be applied to an edge, consisting of broken perforations, unless the edge is less than 3 mm from a POTENTIAL IGNITION SOURCE.</p> <p>The test is not carried out if the —</p> <ul style="list-style-type: none"> - Printed board does not carry any POTENTIAL IGNITION SOURCE; - Base material of printed boards, on which the available apparent power at a connection exceeds 15 VA operating at a voltage exceeding 50 V and equal or less than 400 V (peak) a.c. or d.c. under normal operating conditions, is of flammability category V-1 or better according to AS/NZS 60695.11.10, or the printed boards are protected by an enclosure meeting the flammability category V-0 according to AS/NZS 60695.11.10, or made of metal, having openings only for connecting wires which fill the openings completely; or - Base material of printed boards, on which the available apparatus power at a connection exceeds 15 VA operating at a voltage exceeding 400 V (peak) a.c. or d.c. under normal operating conditions, and base material of printed boards supporting spark gaps which provides protection against overvoltages, is of flammability category V-0 according to AS/NZS 60695.11.10 or the printed boards are contained in a metal enclosure, having openings only for connecting wires which fill the openings completely. Compliance shall be determined using the smallest thickness of the material. <p>NOTE Available apparent power is the maximum apparent power which can be drawn from the supplying circuit through a resistive load whose value is chosen to maximise the apparent power for more than 2 min when the circuit supplied is disconnected.</p>		
6.2.2	<p>For Australia only, delete the first paragraph and Note, and replace with the following:</p> <p>In Australia only, compliance with 6.2.2 shall be checked by the tests of both 6.2.2.1 and 6.2.2.2.</p>	No TNV circuits provided.	N/A
6.2.2.1	<p>For Australia only, delete the first paragraph including the Notes, and replace with the following:</p> <p>In Australia only, the electrical separation is subjected to 10 impulses of alternating polarity, using the impulse test generator reference 1 of Table N.1. The interval between successive impulses is 60 s and the initial voltage, U_c, is: (i)</p>	No TNV circuits provided.	N/A



IEC 60950-1			
Clause	Requirement + Test	Result - Remark	Verdict
National Difference of IEC 60950-1:2005 (Second Edition)			
	for 6.2.1 a): 7.0 kV for hand-held telephones and for headsets and 2.5 kV for other equipment; and (ii) for 6.2.1 b) and 6.2.1 c): 1.5 kV. NOTE 201 The 7 kV impulse simulates lightning surges on typical rural and semi-rural network lines. NOTE 202 The value of 2.5 kV for 6.2.1 a) was chosen to ensure the adequacy of the insulation concerned and does not necessarily simulate likely overvoltages.		
6.2.2.2	For Australia only, delete the second paragraph including the Note, and replace with the following: In Australia only, the a.c. test voltage is: (i) for 6.2.1 a): 3 kV; and (ii) for 6.2.1 b) and 6.2.1 c): 1.5 kV. NOTE 201 Where there are capacitors across the insulation under test, it is recommended that d.c. test voltages are used. NOTE 202 The 3 kV and 1.5 kV values have been determined considering the low frequency induced voltages from the power supply distribution system.	No TNV circuits provided.	N/A
7.3	Add the following before the first paragraph: Equipment providing functions that fall only within the scope of AS/NZS 60065 and that incorporate a PSTN interface, are not required to comply with this Clause where the only ports provided on the equipment, in addition to a coaxial cable connection and a PSTN interface, are audio or video ports and analogue or data ports not intended to be used for telecommunications purposes.	No cable distribution systems	N/A
Annex P	Normative references (List of relevant Australia/New Zealand Standards that have been inserted in place of some of the International Standards)	Complied Check	P

ATTACHMENT TO TEST REPORT IEC 60950-1	
China NATIONAL DIFFERENCES	
Information technology equipment – Safety –	
Part 1: General requirements	
Differences according to	GB4943.1-2011



1.1.2	GB 4943.1-2011 applies to equipment for use at altitudes not exceeding 5000m above sea level, primarily in regions with moderate or tropical climates. Amend the third dashed paragraph of 1.1.2 as: equipment intended to be used in vehicles, on board ships or aircraft, at altitudes greater than 5000m;	Only up to 2000m.	N/A
1.4.5	After the third paragraph, add a paragraph: If the equipment is intended for direct connection	Complied check.	P

IEC 60950-1			
Clause	Requirement + Test	Result - Remark	Verdict
National Difference of IEC 60950-1:2005 (Second Edition)			
	to an AC mains supply, the tolerances on RATED VOLTAGE shall be taken as +10%,-10% unless a wider tolerance is declared by the manufacturer. The first dash paragraph "-the RATED VOLTAGE is 230V single -phase or 400V three-phase, in which case the tolerance shall be taken as +10% and -10%" of IEC 60950-1:2005 is deleted in GB 4943.1-2011		
1.4.12.1	Tma in clause 1.4.12.1 amended as: Tma: is the maximum ambient temperature permitted by the manufacturer's specification, or 35 °C, whichever is greater. Add note 1: For equipment not to be operated at tropical climatic conditions, Tma: is the maximum ambient temperature permitted by the manufacturer's specification, or 25 °C, whichever is greater. Add note 2: For equipment is to be operated at 2000m-5000m above sea leave, its temperature test conditions and temperature limits are under consideration.	40 °C	P
1.5.2	Add a note behind the first break off section in Clause 1.5.2: A component used shall comply with related requirements corresponding altitude of 5000m.	Only up to 2000m.	N/A
1.7	Add one paragraph before the last paragraph: The required marking and instruction should be given in normative Chinese unless otherwise specified.	The requirements have to be checked during national approval.	N/A
1.7.1	Based on the AC mains supply of China, the RATED VOLTAGE should be 220V (single phase) or 380V (three-phases) for single rated voltage, for RATED VOLTAGE RANGE, it should cover 220V or 380V (three-phases), for multiple RATED VOLTAGES, one of them should be 220V or 380V (three-phases) and set on 220V or 380V (three-phases) when manufactured. And the RATED FREQUENCY or RATED FREQUENCY RANGE should be 50Hz or include 50Hz.	Complied check.	P
1.7.2.1	Add requirements of warning for equipment intended to be used at altitudes not exceeding 2000m or at non-tropical climate regions: For equipment intended to be used at altitude not exceeding 2000m, a warning label containing the following or a similar appropriate wording, or a symbol as in annex DD shall fixed to the equipment at readily visible place. "Only used at altitude not exceeding 2000m."	The requirements have to be checked during national approval.	N/A

IEC 60950-1			
Clause	Requirement + Test	Result - Remark	Verdict
National Difference of IEC 60950-1:2005 (Second Edition)			

	 <p>For equipment intended to be used in not-tropical climate regions, a warning label containing the following or a similar appropriate wording, or a symbol as in annex DD shall be fixed to the equipment at readily visible place.</p> <p>"Only used in not-tropical climate regions."</p>  <p>If only the symbol used, the explanation of the symbol shall be contained in the instruction manual.</p> <p>The above statements shall be given in a language acceptable to the regions where the apparatus is intended to be used.</p>		
2.7.1	<p>Amended the first paragraph as:</p> <p>Protection in PRIMARY CIRCUITS against overcurrent short-circuits and earth faults shall be provided as an integral part of the equipment except special provisions. And the protective device shall meet the requirement of Clause 5.3.</p> <p>Delete note of Clause 2.7.1.</p>	Complied check.	P
2.9.2	<p>First section of Clause 2.9.2 amended as two sections:</p> <p>Where required by 2.9.1, 2.10.8.3, 2.10.10 or 2.10.11, humidity conditioning is conducted for 120 h in a cabinet or room containing air with ambient temperature $40\pm 2^{\circ}\text{C}$ and a relative humidity of $(93\pm 3)\%$. During this conditioning the component or subassembly is not energized.</p> <p>For equipment not to be operated at tropical climatic conditions, Where required by 2.9.1, 2.10.8.3, 2.10.10 or 2.10.11, humidity conditioning is conducted for 48 h in a cabinet or room containing air with a relative humidity of $(93\pm 3)\%$. The temperature of the air, at all places where samples can be located, is maintained within 2°C of any convenient value between 20°C and 30°C such that condensation does not occur.</p> <p>Due to pretreatment of equipment operated at high altitude area is humidity conditioning withstand hot shock, specific requirements are to be considered.</p> <p>Add note: For equipment to be operated at 2000 m - 5000m above sea level, assessment and</p>	Complied check.	P

IEC 60950-1			
Clause	Requirement + Test	Result - Remark	Verdict
National Difference of IEC 60950-1:2005 (Second Edition)			
	requirement of humidity conditioning for Insulation material properties are considered.		
2.10.3.1	Amend the third paragraph of Clause 2.10.3.1 to be: These requirements apply for equipment to be operated up to 2000 m above sea level. For equipment to be operated at more than 2000 m above sea level and up to 5000m above sea level, the minimum CLEARANCE shall be multiplied by the factor 1.48 corresponding altitude of 5000m given in Table A.2 of IEC 60664-1. For equipment to be operated at more than 5000 m above sea level, the minimum CLEARANCE shall be multiplied by the factor given in Table A.2 of IEC 60664-1. Linear interpolation is permitted between the nearest two points in Table A.2. The calculated minimum CLEARANCE using this multiplication factor shall be rounded up to the next higher 0,1 mm increment.	Only up to 2000m.	N/A
2.10.3.3& 2.10.3.4	Add "(applicable for altitude up to 2000m)" in header of Table 2K、2L and 2M.	Added.	P
2.10.3.4	Add a new section above Table 2K and in Clause 2.10.3.4: Minimum CLEARANCES determined by above rules apply for equipment to be operated up to 2000m above sea level. For equipment to be operated at 2000 m - 5000m above sea level, the minimum CLEARANCE shall be multiplied by the factor 1.48 corresponding altitude of 5000m given in Table A.2 of GB/T16935.1 (IEC 60664-1). For equipment to be operated at more than 5000 m above sea level, the minimum CLEARANCE shall be multiplied by the factor given in Table A.2 of GB/T16935.1.	Only up to 2000m.	N/A
3.2.1.1	Add a paragraph before the last paragraph: Plugs connected to AC mains supply shall comply with GB 1002 or GB 1003 or GB/T 11918 as applicable.	Direct plug-in equipment.	N/A
4.2.8	Clause 4.2.8 cathode ray tubes quoted Clause 18 of GB8898-2011. Delete note of Clause 4.2.8.	No cathode ray tubes provided.	N/A
Annex E	Last section of Annex E amended as: For comparison of winding temperatures determined by the resistance method of this annex with the temperature limits of Table 4B, 35 °C shall be added to the calculated temperature rise. And add note: for equipment not to be operated at tropical climatic conditions, 25 °C shall be added to the	Not applicable.	N/A

IEC 60950-1			
Clause	Requirement + Test	Result - Remark	Verdict
National Difference of IEC 60950-1:2005 (Second Edition)			
	calculated temperature rise to compare with the temperature of Table 4B.		
Annex G.6	Change the second section of Clause G.6 to be: For equipment to be operated at 2000 m - 5000m above sea level, the minimum CLEARANCE shall be multiplied by the factor 1.48 corresponding altitude of 5000m given in Table A.2 of GB/T16935.1. For equipment to be operated at more than 5000 m above sea level, the minimum CLEARANCE shall be multiplied by the factor given in Table A.2 of IEC 60664-1. Linear interpolation is permitted between the nearest two points in Table A.2. The calculated minimum CLEARANCE using this multiplication factor shall be rounded up to the next higher 0,1 mm increment.	Not applicable.	N/A
Annex BB (informative)	Amended as : The differences between Chinese national standards GB 4943.1-2011 and GB 4943-2001.	Complied check.	P
Annex DD (normative)	Added annex DD: Instructions for the new safety warning labels. DD.1 Altitude warning label  Meaning of the label: Evaluation for apparatus only based on altitude not exceeding 2000m, therefore it's the only operating condition applied for the equipment. There may be some potential safety hazard if the equipment is used at altitude above 2000m. DD.2 Climate warning label  Meaning of the label: Evaluation for apparatus only based on temperate climate condition, therefore it's the only operating condition applied for the equipment. There may be some potential safety hazard if the equipment is used in tropical climate region.	Not applicable.	N/A
Annex EE (informative)	Added annex EE: Illustration relative to safety explanation in normative Chinese, Tibetan, Mongolian, Zhuang Language and Uighu.	Not applicable	N/A
Other	In accordance with the relevant CTL decisions and	Complied check.	P

IEC 60950-1			
Clause	Requirement + Test	Result - Remark	Verdict
National Difference of IEC 60950-1:2005 (Second Edition)			

amendments	the amendments of IEC 60950-1, the specific requirements or mistakes in IEC standard are corrected or editorially modified in this part, Including clause 1.7, 2.1.1.7, 2.9.2, Table 2H, Figure 2H, F.8, F.9, M.3 and Annex U.		
Quoting standards and reference documents	<p>The principles of quoting and referring to other standards in Annex P and reference documents of IEC 60950-1 are as follows:</p> <p>If the date of the reference document is given, only that edition applies, excluding any subsequent corrigenda and amendments. However, parties to agreements based on this part are encouraged to investigate the possibility of applying the most recent editions of the reference documents. For undated references, the latest edition of the referenced document applies, including any corrigenda and amendments.</p> <p>For the usage of international standards in Chinese national standards and industry standards is various, in the aim of achieving easy operation and based on the requirements of GB/T 1.1 and GB/T 20000.2, when quoting an entire international standard in the normative quoting files and reference documents of Annex P of this part, the principles of quotation are as follows:</p> <ul style="list-style-type: none"> - If there is no national standard or industry standard corresponding to the international standard, then the international standard is quoted; - If there is national standard or industry standard corresponding to the international standard, then either the national or industry standard is quoted; - If the date of the national standard or industry standard is not given, the latest edition of the standard applies; - The national standard or industry standard number, corresponding international standard number and the consistency level code should be identified in parentheses behind the listed national standard or industry standard. <p>When quoting several chapters or clauses of the international standard, the principles of quotation are as follows:</p> <ul style="list-style-type: none"> - If there is no national standard or industry standard corresponding to the international standard, then the international standard is quoted; - If there is national standard or industry standard corresponding to the international standard, then either the national or industry standard is quoted. <p>Meanwhile, in order to retain the relevant information on international standards, informative</p>	Complied check.	P

IEC 60950-1			
Clause	Requirement + Test	Result - Remark	Verdict

National Difference of IEC 60950-1:2005 (Second Edition)

	annex CC is increased, which gives the table about the comparison of the normative quoting files and reference documents in IEC 60950-1: 2005 and GB 4943.1-2011.		
--	---	--	--

ATTACHMENT TO TEST REPORT IEC 60950-1

Ireland NATIONAL DIFFERENCES

Information technology equipment – Safety –

Part 1: General requirements

Differences according to: EN 60950-1

3.2.1.1	In Ireland, apparatus which is fitted with a flexible cable or cord and is designed to be connected to a mains socket conforming to I.S. 411 by means of that flexible cable or cord and plug, shall be fitted with a 13 A plug in accordance with Statutory Instrument 525:1997 National Standards Authority of Ireland (section 28) (13 A Plugs and Conversion Adaptors for Domestic Use) Regulations 1997	Direct plug-in equipment.	N/A
4.3.6	In Ireland, DIRECT PLUG-IN EQUIPMENT is known as plug similar devices. Such devices shall comply with Statutory Instrument 526:1997 - National Standards Authority of Ireland (Section 28) (Electrical plugs, plug similar devices and sockets for domestic use) Regulations, 1997.	The main plug has been evaluated according to BS 1363-1: 1995 + A1:1997 + A2: 2003+ A3:2007+ A4: 2012, Report No. TP-12069 (TP12100076-ETS)	P

ATTACHMENT TO TEST REPORT IEC 60950-1

Norway NATIONAL DIFFERENCES

Information technology equipment – Safety –

Part 1: General requirements

Differences according to: EN 60950-1

1.5.7.1	Resistors bridging BASIC INSULATION in CLASS I PLUGGABLE EQUIPMENT TYPE A must comply with the requirements in 1.5.7.2.	No such Resistors provided.	N/A
1.5.8	Due to the IT power system used (see annex V, figure V.7), capacitors are required to be rated for the applicable phase-to-phase voltage (230 V).	No such capacitors provided.	N/A
1.5.9.4	The third dashed sentence is applicable only to equipment as defined by this annex, 6.1.2.2	No such VDR provided.	N/A
1.7.2.1	Class I Pluggable Equipment Type A intended for connection to other equipment or a network shall, if	Class II equipment.	N/A

IEC 60950-1			
Clause	Requirement + Test	Result - Remark	Verdict
National Difference of IEC 60950-1:2005 (Second Edition)			

	safety relies on connection to protective earth or if surge suppressors are connected between the network terminals and accessible parts, have a marking stating that the equipment must be connected to an earthed mains socket-outlet. The marking text shall be: "Apparatet ma tilkoples jordet stikkontakt"		
2.2.4	Requirements according to this annex, 1.7.2.1, 6.1.2.1 and 6.1.2.2 apply.	No TNV circuits provided.	N/A
2.3.2	Requirements according to this annex, 6.1.2.1 and 6.1.2.2 apply.	No TNV circuits provided.	N/A
2.3.4	Requirements according to this annex, 1.7.2.1, 6.1.2.1 and 6.1.2.2 apply.	No TNV circuits provided.	N/A
2.10.5.13	Requirements according to this annex, 6.1.2.1 and 6.1.2.2 apply.	No TNV circuits provided.	N/A
5.1.7.1	Touch current measurement results exceeding 3,5 mA r.m.s are permitted only for the following equipment: - Stationary pluggable equipment Type A that: (1) is intended to be used in a Restricted Access Location where equipotential bonding has been applied, for example, in a telecommunication centre; and (2) has provision for a permanently connected protective earthing conductor; and (3) is provided with instructions for the installation of that conductor by a service person; - Stationary pluggable equipment Type B - Stationary permanently connected equipment	Touch current does not exceed 3.5mA	N/A
6.1.2.1	Add the following text between the first and second paragraph of the compliance clause: If this insulation is solid, including insulation forming part of a component, it shall at least consist of either - two layers of thin sheet material, each of which shall pass the electric strength test below, or - one layer having a distance through insulation of at least 0,4 mm, which shall pass the electric strength test below. If this insulation forms part of a semiconductor component (e.g. an optocoupler), there is no distance through insulation requirement for the insulation consisting of an insulating compound completely filling the casing, so that CLEARANCES and CREEPAGE DISTANCES do not exist, if the component passes the electric strength test in accordance with the compliance clause below and in addition	No TNV circuits provided.	N/A

IEC 60950-1			
Clause	Requirement + Test	Result - Remark	Verdict
National Difference of IEC 60950-1:2005 (Second Edition)			

	<p>- passes the tests and inspection criteria of 2.10.11 with an electric strength test of 1,5 kV multiplied by 1,6 (the electric strength test of 2.10.10 shall be performed using 1,5 kV), and</p> <p>- is subject to ROUTINE TESTING for electric strength during manufacturing, using a test voltage of 1,5 kV.</p> <p>It is permitted to bridge this insulation with a capacitor complying with EN 132400:1994, subclass Y2.</p> <p>A capacitor classified Y3 according to EN 132400:1994, may bridge this insulation under the following conditions:</p> <p>- the insulation requirements are satisfied by having a capacitor classified Y3 as defined by EN 132400, which in addition to the Y3 testing, is tested with an impulse test of 2,5 kV defined in EN 60950-1:2006, 6.2.2.1;</p> <p>- the additional testing shall be performed on all the test specimens as described in EN 132400;</p> <p>- the impulse test of 2,5 kV is to be performed before the endurance test in EN 132400, in the sequence of tests as described in EN 132400.</p>		
6.1.2.2	The exclusions are applicable for permanently connected equipment and pluggable equipment type B and equipment intended to be used in a restricted access location where equipotential bonding has been applied, e.g. in a telecommunication centre, and which has provision for a permanently connected protective earthing conductor and is provided with instructions for the installation of that conductor by a service person.	No TNV circuits provided.	N/A
7.2	Requirements according to this annex, 6.1.2.1 and 6.1.2.2 apply with the term telecommunication network in 6.1.2 being replaced by the term cable distribution system.	No cable distribution systems	N/A
7.3	There are many buildings where the screen of the coaxial cable is not normally connected to the earth in the building installation	No cable distribution systems	N/A
7.3	Refer to EN 60728-11:2005 for installation conditions	No cable distribution systems	N/A

<p>ATTACHMENT TO TEST REPORT IEC 60950-1</p> <p>Spain NATIONAL DIFFERENCES</p> <p>Information technology equipment – Safety –</p> <p>Part 1: General requirements</p>

ATTACHMENT

Page 49 of 59

Report No. PSE104-0004

IEC 60950-1			
Clause	Requirement + Test	Result - Remark	Verdict

National Difference of IEC 60950-1:2005 (Second Edition)

Differences according to	UNE EN 60950-1
---------------------------------------	----------------

3.2.1.1	<p>In Spain, supply cords of single-phase equipment having a rated current not exceeding 10 A shall be provided with a plug according to UNE 20315:1994.</p> <p>Supply cords of single-phase equipment having a rated current not exceeding 2,5 A shall be provided with a plug according to UNE-EN 50075:1993.</p> <p>CLASS I EQUIPMENT provided with socket-outlets with earth contacts or which are intended to be used in locations where protection against indirect contact is required according to the wiring rules, shall be provided with a plug in accordance with standard UNE 20315:1994.</p> <p>If poly-phase equipment is provided with a supply cord with a plug, this plug shall be in accordance with UNE-EN 60309-2.</p>	No socket-outlets provided.	N/A
---------	--	-----------------------------	-----

ATTACHMENT TO TEST REPORT IEC 60950-1

Switzerland NATIONAL DIFFERENCES

Information technology equipment – Safety –

Part 1: General requirements

Differences according to	SN EN 60950-1:2006
---------------------------------------	--------------------

1.5.1	Add NOTE: Switches containing mercury such as thermostats, relays and level controllers are not allowed.	Not applicable.	N/A
1.7.13	Annex 2.15 of SR 814.81 applies for batteries	Same as above.	N/A
3.2.1.1	<p>Supply cords of equipment having a rated current not exceeding 10 A shall be provided with a plug complying with SEV 1011 or IEC 60884-1 and one of the following dimension sheets:</p> <p>SEV 6532-2.1991, Plug type 15, 3P+N+PE 250/400 V, 10 A</p> <p>SEV 6533-2.1991, Plug type 11, L+N 250 V, 10 A</p> <p>SEV 6534-2.1991, Plug type 12, L+N+PE 250 V, 10 A</p> <p>In general, EN 60309 applies for plugs for currents exceeding 10 A. However, a 16 A plug and socket-outlet system is being introduced in Switzerland, the plugs of which are according to</p>	Same as above.	N/A

ATTACHMENT

Page 50 of 59

Report No. PSE104-0004

IEC 60950-1			
Clause	Requirement + Test	Result - Remark	Verdict

National Difference of IEC 60950-1:2005 (Second Edition)			
---	--	--	--

	<p>the following dimension sheets, published in February 1998:</p> <p>SEV 5932-2.1998, Plug type 25, 3P+N+PE 230/400 V, 16 A</p> <p>SEV 5933-2.1998, Plug type 21, L+N 250 V, 16 A</p> <p>SEV 5934-2.1998, Plug type 23, L+N+PE 250 V, 16 A</p>		
3.2.4	Requirements according to this annex, 3.2.1.1 apply	Same as above.	N/A

IEC 60950-1			
Clause	Requirement + Test	Result - Remark	Verdict

National Difference of IEC 60950-1:2001 (First Edition)

ATTACHMENT TO TEST REPORT IEC 60950-1 Japan NATIONAL DIFFERENCES Information technology equipment – Safety – Part 1: General requirements	
Differences according to.....:	J60950-1 (H22)

1.2.4.1	Add the following new notes. Note: Even if the equipment is designed as Class I, the equipment is regarded as Class 0I equipment when 2-pin adaptor with earthing lead wire or cord set having 2-pin plug with earthing lead wire is provided or recommended.	Class II equipment.	N/A
1.2.4.3A	Add the following new clause. 1.2.4.3A CLASS 0I EQUIPMENT Equipment having attachment plug without earthing blade, where protection against electric shock is achieved by: - using BASIC INSULATION, and - providing externally an earth terminal or a lead wire for earthing in order to connect those conductive parts that might assume a HAZARDOUS VOLTAGES in the event of BASIC INSULATION fault to the PROTECTIVE EARTHING CONDUCTOR in the building wiring. NOTE – Class 0I equipment may have a part constructed with Double Insulation or Reinforced Insulation. circuit.	Not applicable.	N/A
1.3.2	Add the following notes after first paragraph: Note 1 Transportable or similar equipment that are relocated frequently for intended usage should not be designed as Class I or Class 0I equipment unless it is intended to be installed by service personnel. Note 2 Considering wiring circumstance in Japan, equipment intended to be installed where the provision for earthing connection is unlikely should not be designed as Class I or Class 0I equipment unless it is intended to be installed by service personnel.	Not applicable.	N/A
1.5.1	Replace the first paragraph with the follows: Where safety is involved, components shall comply either with the requirements of this standard, with the safety aspects of the relevant JIS component standard, or IEC component standards in case there is no applicable JIS component standard is available. However, a component that falls within	Complied check.	P

IEC 60950-1			
Clause	Requirement + Test	Result - Remark	Verdict
National Difference of IEC 60950-1:2001 (First Edition)			

	<p>the scope of METI Ministerial ordinance No. 85 is properly used in accordance with its marked ratings, requirements of 1.5.4, 2.8.7 and 3.2.5 apply, and in addition, a cord connector of power supply cord set mating with appliance inlet complying with the standard sheet of IEC 60320-1, shall comply with relevant standard sheet of IEC 60320-1.</p> <p>Replace Note 1 with the following: Note 1 A JIS or an IEC component standard is considered relevant only if the component in question clearly falls within its scope.</p>		
1.5.2	<p>Replace first sentence in the first dashed paragraph with the following: a component that has been demonstrated to comply with a JIS component standard harmonized with the relevant IEC component standard, or where such JIS component standard is not available, a component that has been demonstrated to comply with the relevant IEC component standard shall be checked for correct application and use in accordance with its rating. Add a note after the first dashed paragraph as follows: Note 1 See 1.7.5A when Type C.14 appliance coupler rated 10 A per IEC 60320-1 is used with an equipment rated not more than 125 V and rated more than 10 A. Replace first sentence in the third dashed paragraph as follows: where no relevant IEC component standard or JIS component standard harmonized with the relevant IEC component standard exists, or where components are used in circuits not in accordance with their specified rating, the components shall be tested under the conditions occurring in the equipment.</p>	Complied check.	P
1.7.1	<p>Replace fifth dashed paragraph with the following: - manufacturer's or responsible company's name or trade-mark or identification mark;</p>	The requirements have to be checked during national approval.	N/A
1.7.5A	<p>Add the following new clause. after 1.7.5 1.7.5A Appliance Coupler If appliance coupler according to IEC60320-1, C.14(rated current: 10A)is used in equipment whose rated voltage is less than 125V and rated current is over 10A, the following instruction or equivalent shall be described in the user instruction.</p>	No socket-outlets provided.	N/A

IEC 60950-1			
Clause	Requirement + Test	Result - Remark	Verdict
National Difference of IEC 60950-1:2001 (First Edition)			
	" Use only designated cord set attached in this equipment"		
1.7.12	Replace first sentence with the following: Instructions and equipment marking related to safety shall be in Japanese..	Reviewed only English markings/instructions. May be provided in other languages upon request from the manufacturer.	N/A
1.7.17A	Add the following new clause. after 1.7.17 1.7.17A Marking for CLASS 0I EQUIPMENT For CLASS 0I EQUIPMENT, the following instruction shall be marked on the visible place of the mains plug or the main body: "Provide an earthing connection" Moreover, for CLASS 0I EQUIPMENT, the following or equivalent instruction shall be indicated on the visible place of the main body or written in the operating instructions: "Provide an earthing connection before the mains plug is connected to the mains. And, when disconnecting the earthing connection, be sure to disconnect after pulling out the mains plug from the mains."	Not applicable.	N/A
2.6.3.2	Add the following after 1st paragraph. This also applies to the conductor of lead wire for protective earthing of CLASS 0I EQUIPMENT.	Class II equipment.	N/A
2.6.4.2	Replace 1st paragraph with the following. Equipment required to have protective earthing shall have a main protective earthing terminal. For equipment with a DETACHABLE POWER SUPPLY CORD, the earthing terminal in the appliance inlet is regarded as the main protective earthing terminal except for CLASS 0I EQUIPMENT providing separate main protective earthing terminal other than appliance inlet.	Class II equipment.	N/A
2.6.5.4	Replace 1st sentence with the following. Protective earthing connections of CLASS I EQUIPMENT shall make earlier and break later than the supply connections in each of the following:	Class II equipment.	N/A
2.6.5.8A	Add the following new clause. after 2.6.5.8A 2.6.5.8A Earthing of CLASS 0I EQUIPMENT Plugs with a lead wire for earthing shall not be used for equipment having a rated voltage	Class II equipment.	N/A

IEC 60950-1													
Clause	Requirement + Test			Result - Remark	Verdict								
National Difference of IEC 60950-1:2001 (First Edition)													
	<p>exceeding 150V.</p> <p>For plugs with a lead wire for earthing, the lead wire shall not be earthed by a clip.</p> <p>CLASS 0I EQUIPMENT shall be provided with an earthing terminal or lead wire for earthing in the external location where easily visible.</p>												
3.2.3	<p>Add the following after Table 3A:</p> <p>Table 3A applies when cables complying with JIS C 3662 or JIS C 3663 are used. In case of other cables, cable entries shall be so designed that a conduit suitable for the cable used can be fitted.</p>			The equipment is not permanently connected.	N/A								
3.2.5.1	<p>Add the following to the last of first dashed paragraph.</p> <p>Or mains cords shall be of the sheathed type complying with Appendix 1 of Article 1 of the Ministerial Ordinance on stipulating technical requirements for the Electrical Appliance..</p> <p>Add the following to the last of second dashed paragraph.</p> <p>Or mains cords shall be of the sheathed type complying with Appendix 1 of Article 1 of the Ministerial Ordinance on stipulating technical requirements for the Electrical Appliance..</p> <p>Delete 1) in Table 3B.</p>			Direct plug-in equipment.	N/A								
3.3.4	<p>Add the following note to Table 3D:</p> <p>Note For cables other than those complying with JIS C 3662 or JIS C 3663, terminals shall be suitable for the size of the intended cables.</p>			The equipment is not permanently connected or provided with a non-detachable power supply cord	N/A								
3.3.7	<p>Add the following after the first sentence:</p> <p>This requirement is not applicable to the external earthing terminal of Class 0I equipment.</p>			The equipment is not permanently connected or provided with a non-detachable power supply cord	N/A								
4.3.4	<p>Add the following after the first sentence:</p> <p>This requirement also applies to those connections in Class 0I equipment, where CLEARANCE or CREEPAGE DISTANCES over BASIC INSULATION would be reduced to less than the values specified in 2.10.</p>			Class II equipment.	N/A								
5.1.3	<p>Add a note after the first paragraph as follows:</p> <p>Note – Attention should be drawn to that majority of three-phase power system in Japan is of delta connection, and therefore, in that case, test is conducted using the test circuit from IEC 60990, figure 13.</p>			Not applicable.	N/A								
5.1.6	<p>Replace Table 5A. as follows</p> <table border="1" style="width: 100%; border-collapse: collapse;"> <thead> <tr> <th>Type of equipment</th> <th>Terminal A of</th> <th>Maximum</th> <th>Maximum</th> </tr> </thead> <tbody> <tr> <td> </td> <td> </td> <td> </td> <td> </td> </tr> </tbody> </table>			Type of equipment	Terminal A of	Maximum	Maximum					Complied check.	P
Type of equipment	Terminal A of	Maximum	Maximum										

IEC 60950-1			
Clause	Requirement + Test	Result - Remark	Verdict
National Difference of IEC 60950-1:2001 (First Edition)			

	measuring instrument connected to:	TOUCH CURRENT mAr.m.s.1)	PROTECTIVE CONDUCTOR CURRENT		
	ALL equipment	ALL equipment Accessible parts and circuits not connected to protective earth	0,25	-	
	HANDHELD	Equipment main protective	0,75	-	
	MOVABLE (other than HAND_HELD, but including TRANSPORTABLE EQUIPMENT	earthing terminal (if any) CLASS I EQUIPMENT	3,5	-	
	STATIONARY, PLUGGABLE TYPE A		3,5	-	
	ALL other STATIONARY EQUIPMENT -not subject to the conditions of 5.1.7 -subject to the conditions of 5.1.7		3,5 -	- 5% of input current	
	HANDHELD	Equipment main protective	0,5	-	
	Others	earthing terminal (if any) CLASS II EQUIPMENT	1,0	-	
	1) If peak values of TOUCH-CURRENT are measured, the maximum values obtained by multiplying the r.m.s. values by 1,414.				
7.2	Add the following after the paragraph: However, the separation requirements and tests of 6.2.1 a), b) and c) do not apply to a CABLE DISTRIBUTION SYSTEM if all of the following apply: – the circuit under consideration is a TNV-1 CIRCUIT; and – the common or earthed side of the circuit is connected to the screen of the coaxial cable and to all accessible parts and circuits (SELV, accessible metal parts and LIMITED CURRENT CIRCUITS, if any); and – the screen of the coaxial cable is intended to be connected to earth in the building installation.		No cable distribution system.		N/A

IEC 60950-1			
Clause	Requirement + Test	Result - Remark	Verdict
National Difference of IEC 60950-1:2001 (First Edition)			

W.1	<p>Replace second and third sentence in the first paragraph with the following:</p> <p>This distinction between earthed and unearthed (floating) circuit is not the same as between CLASS I EQUIPMENT, CLASS 0I EQUIPMENT and CLASS II EQUIPMENT. Floating circuits can exist in CLASS I EQUIPMENT or CLASS 0I EQUIPMENT and earthed circuits in CLASS II EQUIPMENT.</p>	No TNV circuit provided.	N/A
Annex JA	<p>Add a new annex JA with the following contents.</p> <p>Annex JA (normative)</p> <p>Document shredding machines</p> <p>Document shredding machines shall also comply with the requirements of this annex except those of STATIONARY EQUIPMENT used by connecting directly to an AC MAINS SUPPLY of three-phase 200V or more.</p> <p>JA.1 Markings and instructions</p> <p>The symbol</p> <p> (JIS S 0101:2000, 6.2.4) and the following precautions for use shall be marked on readily visible part adjacent to document feed opening. The marking shall be clearly legible, permanent, and easily discernible;</p> <ul style="list-style-type: none"> - that use by an infants/children may cause a hazard of injury etc.; - that a hand can be drawn into the mechanical section for shredding when touching the document-slot; - that clothing can be drawn into the mechanical section for shredding when touching the document-slot; - that hairs can be drawn into the mechanical section for shredding when touching the document-slot; - in case of equipment incorporating a commutator motor, that equipment may catch fire or explode by spraying of flammable gas. <p>JA.2 Inadvertent reactivation</p> <p>Any safety interlock that can be operated by means of the test finger, Figure JA.1, is considered to be likely to cause inadvertent reactivation of the hazard.</p> <p>Compliance is checked by inspection and, where necessary, by a test with the test finger, Figure JA.1</p>	Not applicable.	N/A

IEC 60950-1			
Clause	Requirement + Test	Result - Remark	Verdict

National Difference of IEC 60950-1:2001 (First Edition)
--

	<p>JA.3 Disconnection from the mains supply</p> <p>Document shredding machines shall incorporate an isolating switch complying with sub-clause 3.4.2 as the device disconnecting the power of hazardous moving parts. For this switch, two-position (single-use) switch or multi-position (multifunction) switch (e.g., slide switch) may be used.</p> <p>If two-position switch, the positions for "ON" and "OFF" shall be indicated in accordance with sub-clause 1.7.8. If multi-position switch, the position for "OFF" shall be indicated in accordance with sub-clause 1.7.8 and other positions shall be indicated with proper terms or symbols.</p> <p>Compliance is checked by inspection</p> <p>JA.4 Protection against hazardous moving parts</p> <p>Any warning shall not be used instead of the structure for preventing access to hazardous moving parts.</p> <p>Document shredding machines shall comply with the following requirements.</p> <p>Insert the test finger, Figure JA.1, into all openings in MECHANICAL ENCLOSURES without applying appreciable force. It shall not be possible to touch hazardous moving parts with the test finger. This consideration applies to all sides of MECHANICAL ENCLOSURES when the equipment is mounted as intended. Before testing with the test finger, remove the parts detachable without a tool.</p> <p>Insert the wedge-probe, Figure JA.2, into the document-slot. And, against all directions of openings, if straight-cutting type, a force of 45 N shall apply to the probe, and 90 N if cross-cutting type. In this case, the weight of the probe is to be factored into the overall applied force. Before testing with the wedge-probe, remove the parts detachable without a tool. It shall not be possible to touch any hazardous moving parts, including the shredding roller or the mechanical section for shedding, with the probe.</p>		
--	--	--	--

IEC 60950-1			
Clause	Requirement + Test	Result - Remark	Verdict
National Difference of IEC 60950-1:2001 (First Edition)			

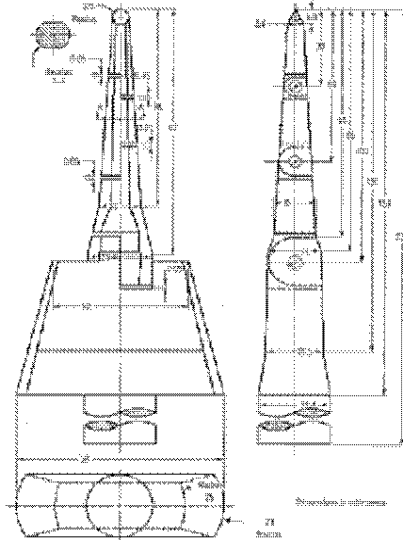

Figure JA.1 Test finger

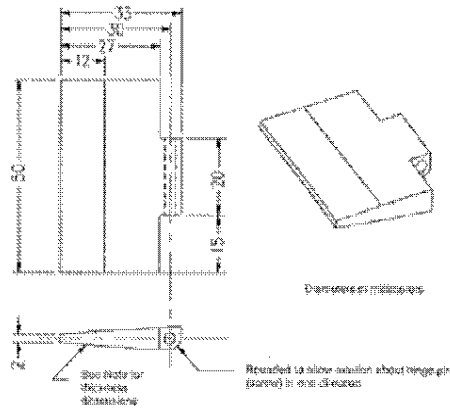

Figure JA.2 Wedge-probe

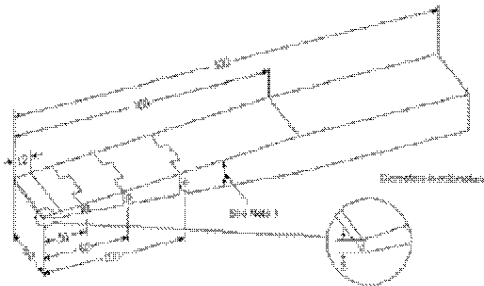

Figure JA.2 Wedge-probe
(Details of the tip of wedge)

Distance from the tip (mm)	Thickness of probe (mm)
0	2

ATTACHMENT

Page 59 of 59

Report No. PSE104-0004

IEC 60950-1			
Clause	Requirement + Test	Result - Remark	Verdict

National Difference of IEC 60950-1:2001 (First Edition)
--

	12	4		
	180	24		
<p>Note 1 - The thickness of the probe varies linearly, with slope changes at the respective points shown in the table.</p> <p>Note 2 –The allowable dimensional tolerance of the probe is +/- 0.127 mm.</p>				

PHOTO

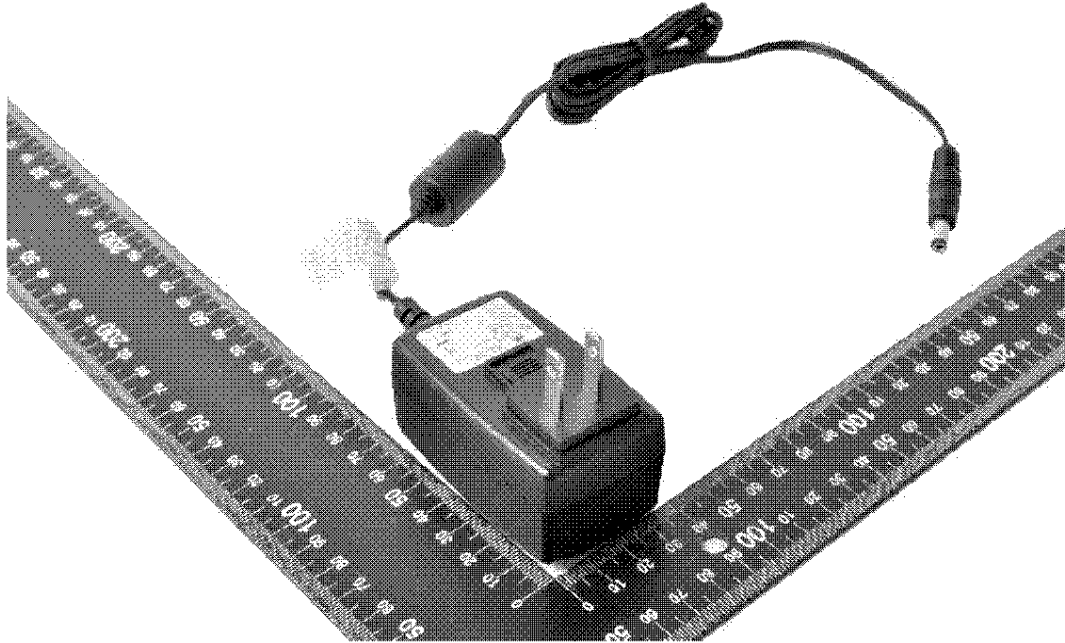

Enclosure rear (United State plug)

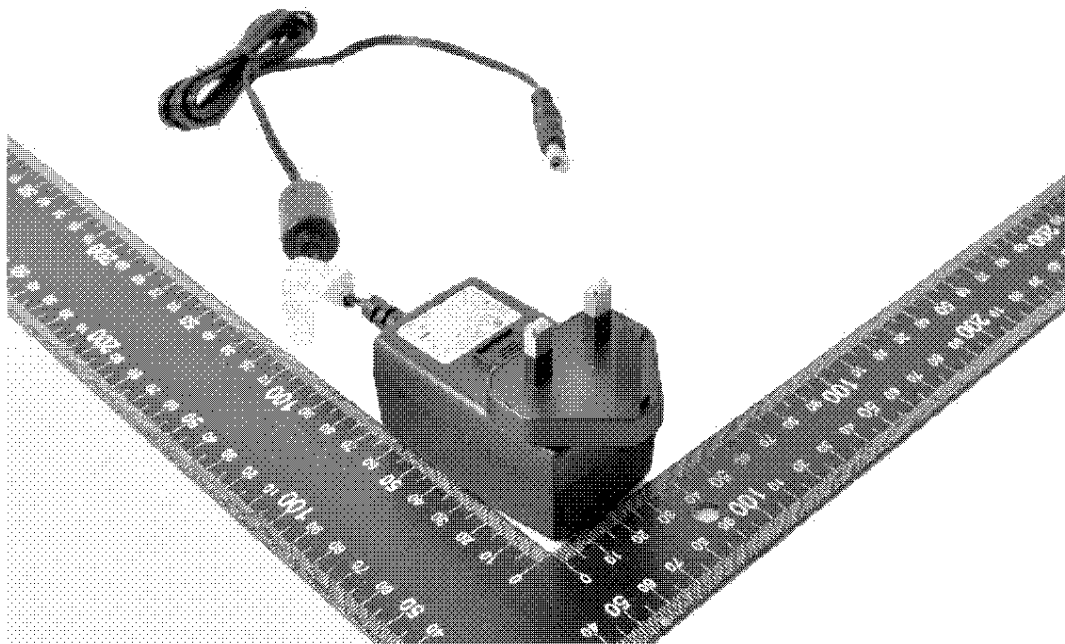

Enclosure rear (United Kingdom plug)

PHOTO

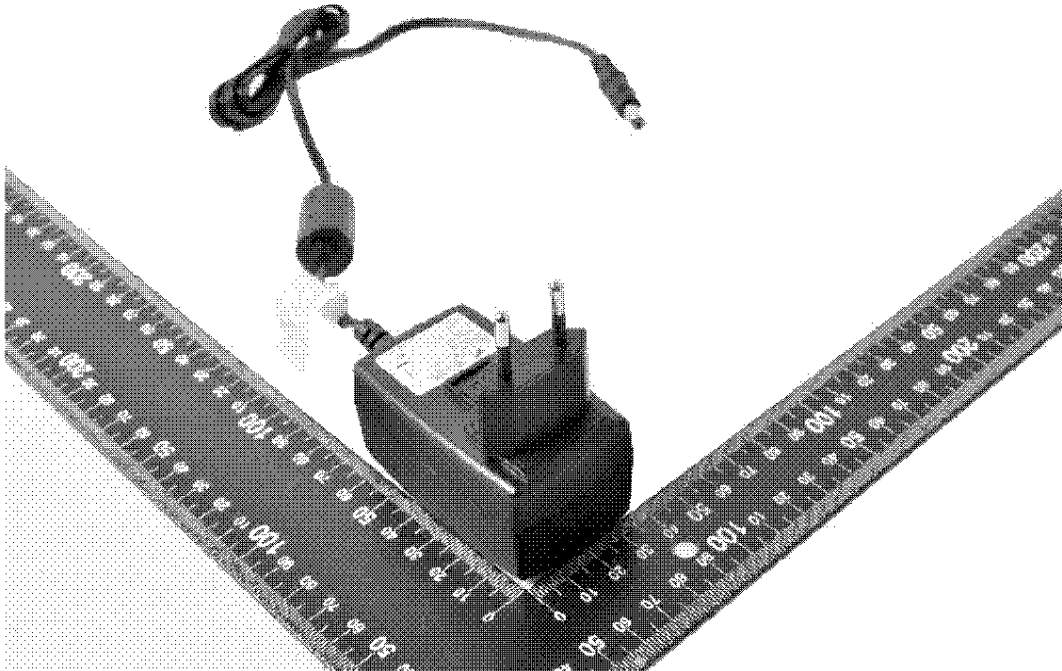

Enclosure rear (Europe Plug)

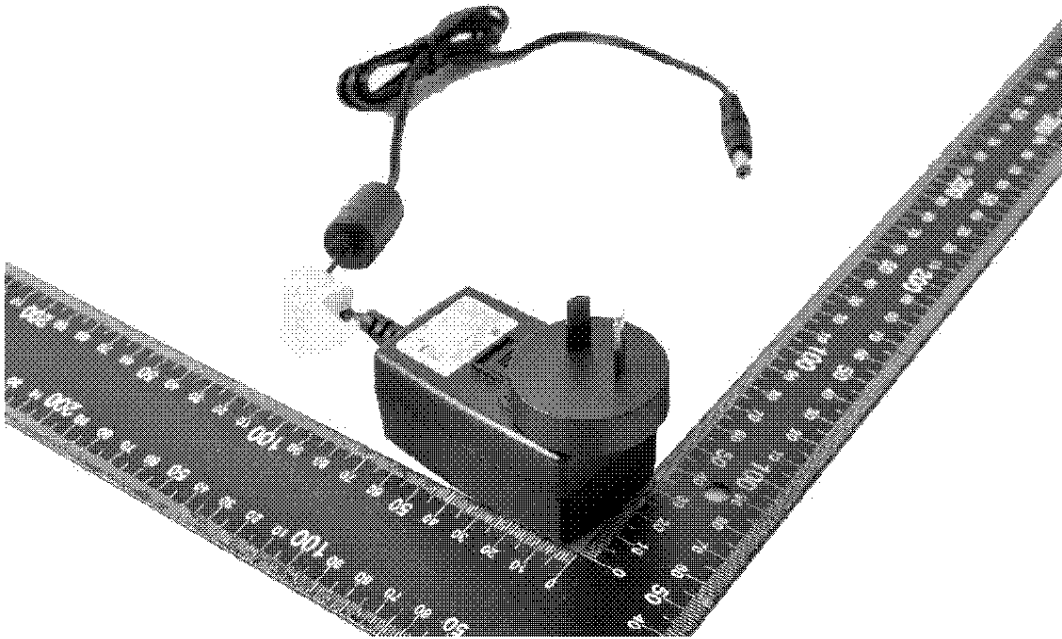

Enclosure rear (Australia Plug)

PHOTO

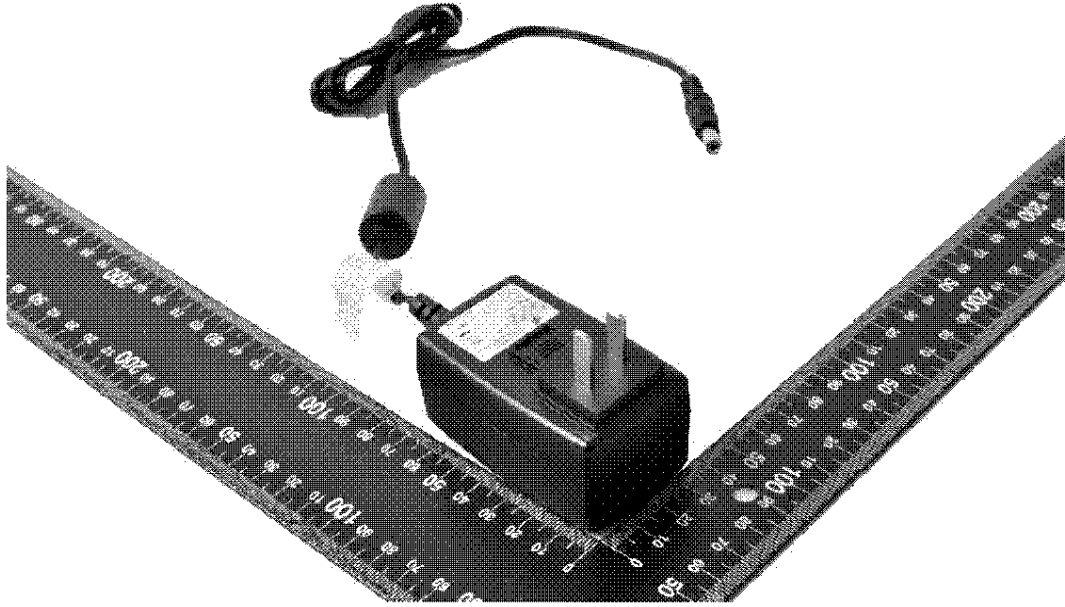

Enclosure rear (China Plug)

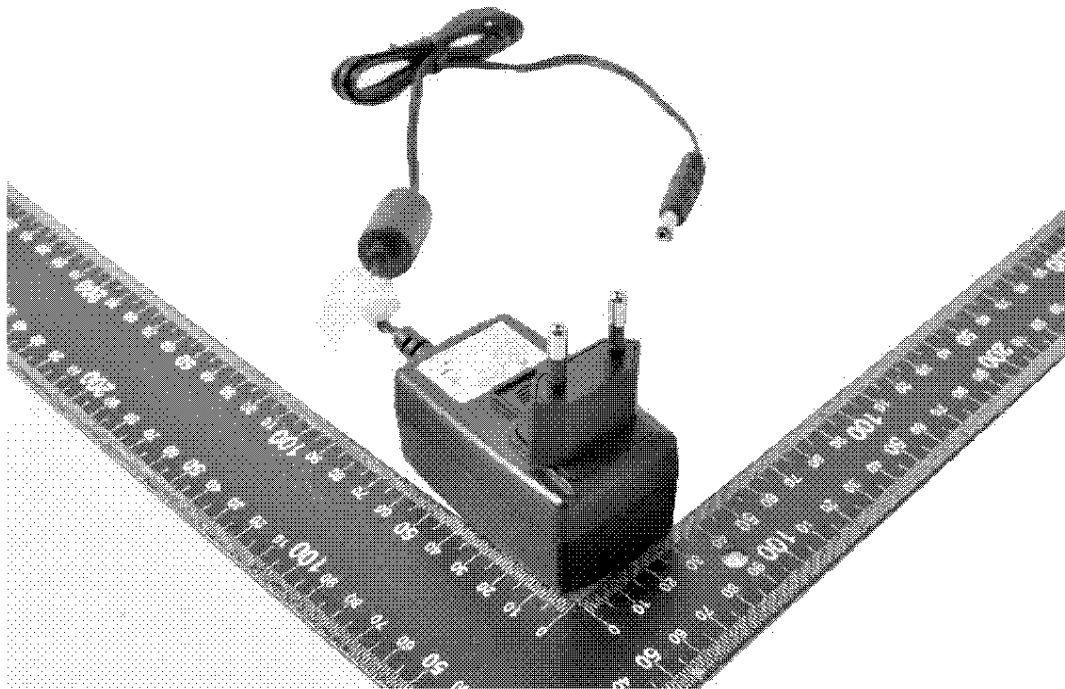

Enclosure rear (Korea Plug)

PHOTO

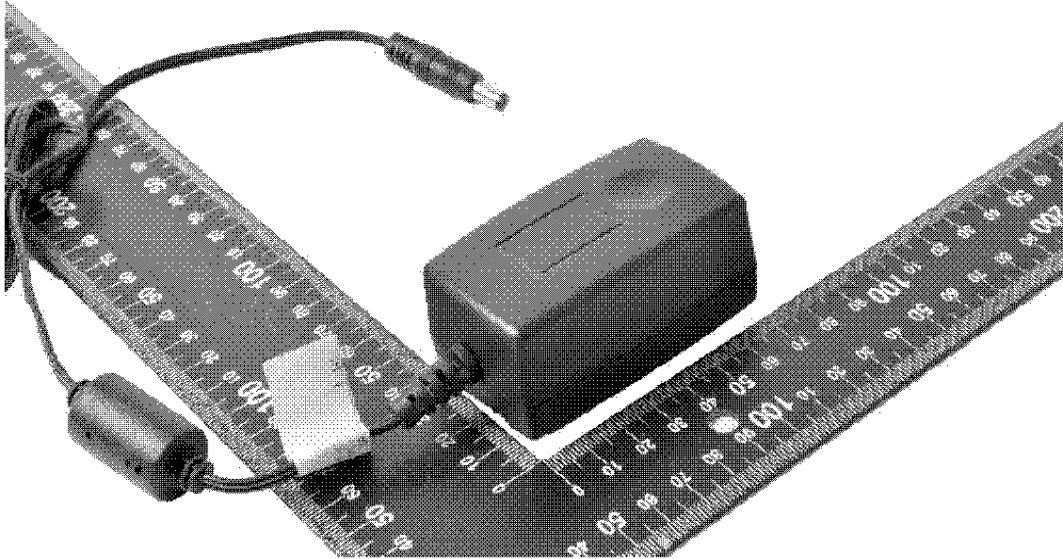

Enclosure top (all plugs)

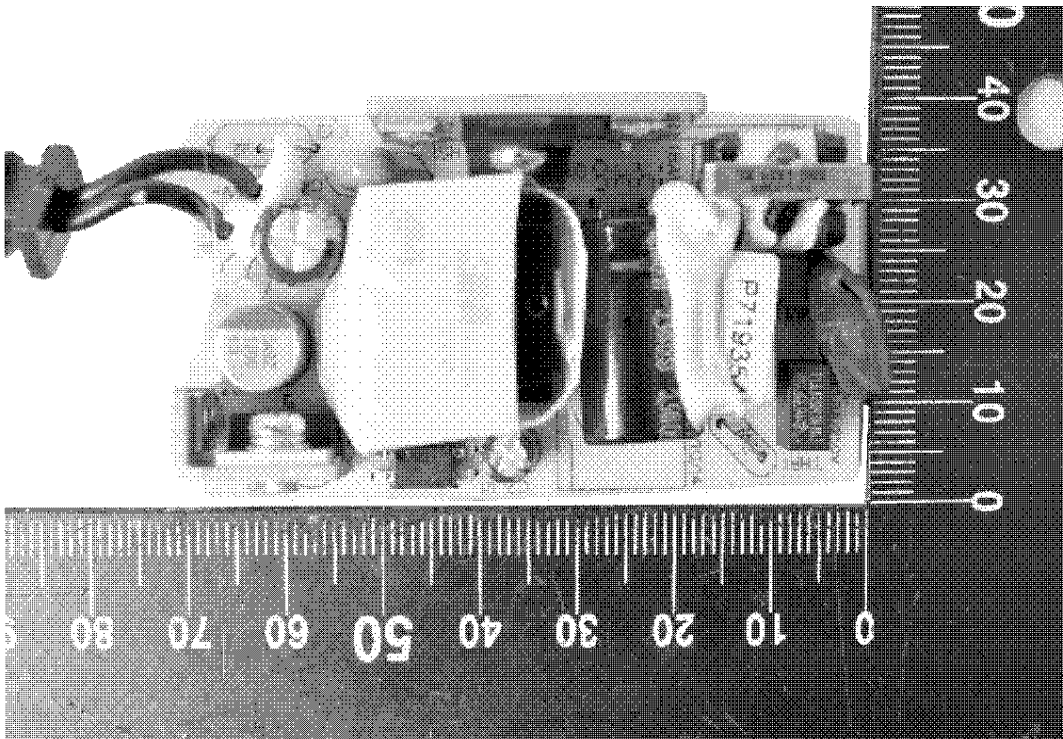

Provided HS2

PHOTO

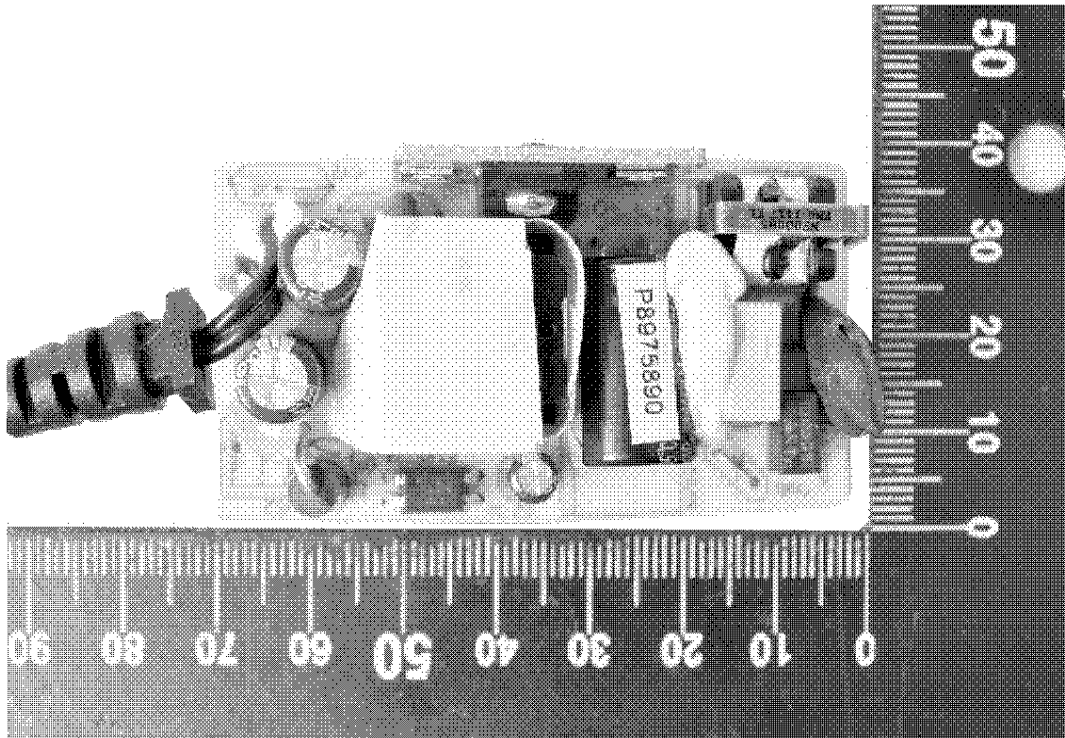

No HS2 provided

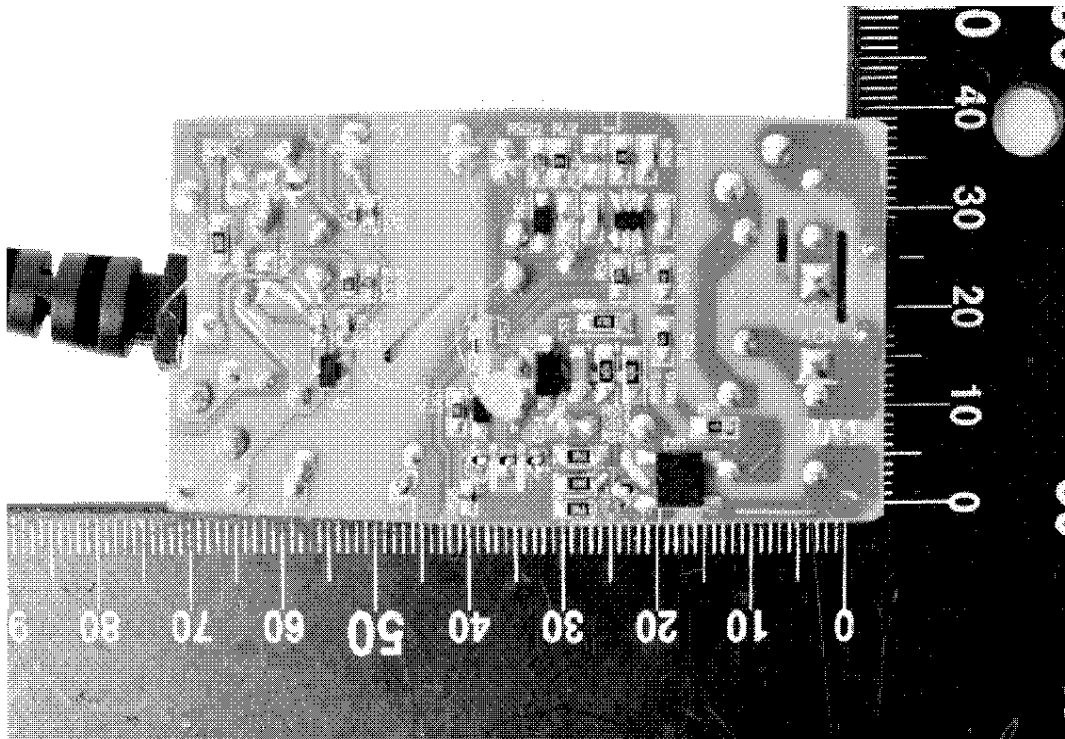

Issue Date: 2015-08-11

Page 1 of 1
Test Record

Report Reference #

E341351-A70-UL

Test Record No. 1