



www.lcs-cert.com

試験報告書番号: Test Report No.	LCS180507172AS	頁: Page 1 of 18
申請者: Applicant:	GlobTek, Inc. 186 Veterans Dr. Northvale, NJ 07647 USA	
製造者: Manufacturer:	GlobTek, Inc. 186 Veterans Dr. Northvale, NJ 07647 USA	
試験品: Test item:	Lithium-ion Battery Pack	
識別表示: Identification:	BL3600F4634462S4PH6G	製造番号: Engineering sample Serial No.:
申請受理番号: Receipt No.:	180507172A	申請受理日: 2018-07-11 Date of receipt:
試験場所: Testing location:	Shenzhen LCS Compliance Testing Laboratory Ltd. Xingyuan Industrial Park, Tongda Road, Bao'an Avenue, Bao'an District, Shenzhen, Guangdong, China	
適用した試験基準: Test specification:	電気用品の技術上の基準を定める省令の解釈(H25.07.01) 別表第九リチウムイオン蓄電池 Interpretation for METI Ordinance of Technical Requirements (H25.07.01) Appendix 9 : Lithium ion secondary batteries	
試験所: Testing Laboratory:	Shenzhen LCS Compliance Testing Laboratory Ltd. Xingyuan Industrial Park, Tongda Road, Bao'an Avenue, Bao'an District, Shenzhen, Guangdong, China	
試験結果: Test result:	上記試験品は、適合した。 The a. m. test item passed.	
備考/Other Aspects: 電気用品安全法 – 特定電気用品以外の電気用品 – リチウムイオン蓄電池 Electrical Appliance and Material Safety Law – Other electrical appliances and materials – Li-Ion secondary batteries	試験者: Tested by:	2018-12-13 Rick Zhu <i>Rick Zhu</i>
検査者: checked by:	承認者: approved by:	
2018-12-13 Smart Shi <i>Smart Shi</i>	2018-12-13 Hart Qiu	
日付 Date	氏名 Name	署名 Signature
日付 Date	氏名 Name	署名 Signature
略語: OK, Pass or P = 適合 F or Fail = 不適合 N/A or N = 該当せず	Abbreviations: OK, Pass or P = passed F or Fail = failed N/A or N = not applicable	
この試験報告書は上記試験品に関するものであり、当該試験所の許可無しに、この試験報告書を抜粋し複写してはいけません。 また、この試験報告書は、当該製品又は類似製品に何れかの試験マークを附す権利を与えるものではありません。 This test report relates to the a. m. test item. Without permission of the test centre this test report is not permitted to be duplicated in extracts. This test report does not entitle to carry any test mark on this or similar products.		

Test item description		Lithium-ion Battery Pack
Model/Type reference	:	BL3600F4634462S4PH6G
Manufacturer	:	GlobTek, Inc. 186 Veterans Dr. Northvale, NJ 07647 USA
Factory	:	
Seller Name of Trade mark	:	 GlobTek, Inc.
Ratings	:	7.4V, 36 00mAh, 26.64 Wh
Possible test case verdicts:		
- test case does not apply to the test object : N/A		
- test object does meet the requirement : P (Pass)		
- test object does not meet the requirement : F (Fail)		
Testing:		
Date of receipt of test item ...	:	2018-07-11
Date (s) of performance of tests	:	2018-07-11 to 2018-12-09
General remarks:		
The test results presented in this report relate only to the object tested. This report shall not be reproduced, except in full, without the written approval of the Issuing testing laboratory. The completed test report includes the Attachment 1: Equipment list (2 pages) and Attachment 2: Photo documents (4 pages).		
The completed test report includes the Throughout this report a point is used as the decimal separator		

Copy of marking plate:

 **GlobTek, Inc.**
www.globtek.com
Lithium-Ion Battery Pack

Li-ion 7.4V 3600mAh 26.64Wh

BL3600F4634462S4PH6G

CAUTION:

- May explode if disposed of in fire
- Use specified charger only.
- Do not short circuit.

2ICP5/34/49-4

 
XXX株式会社

  
c us Li-ion 00

YYYYMM **MADE IN CHINA**

General product information:

This Li-ion Batteries is constructed with eight lithium-ion cells (2S4P), and has overcharge, over-discharge, over current and short-circuits proof circuit.

The main features of this model are shown as below:

Model	Nominal capacity	Nominal voltage	Nominal Charge Current	Nominal Discharge Current	Maximum Charge Current	Maximum Discharge Current	Maximum Charge Voltage	Cut-off Voltage
BL3600F463 4462S4PH6G	3600mAh	7.4V	720mA	720mA	2000mA	3000mA	8.4V	5.6V

The main features of this cell within the Power Bank shown as below:

Model	Nominal capacity	Nominal voltage	Nominal Charge Current	Nominal Discharge Current	Maximum Charge Current	Maximum Discharge Current	Maximum Charge Voltage	Cut-off Voltage
UF463450F	920mAh	3.7V	184mA	184mA	920mA	1840mA	4.2V	2.75V

Construction:

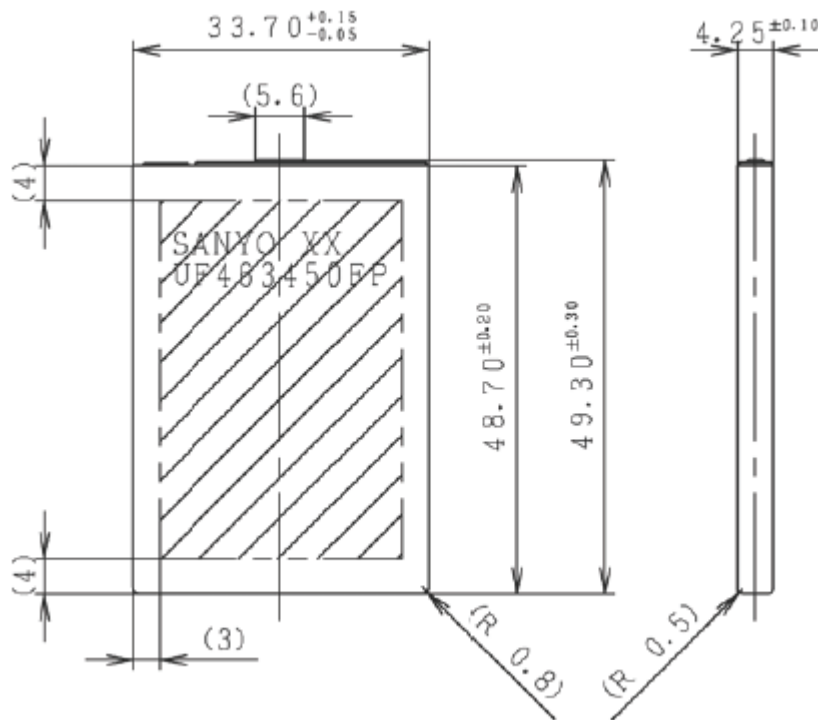

Cell(Unit: mm)

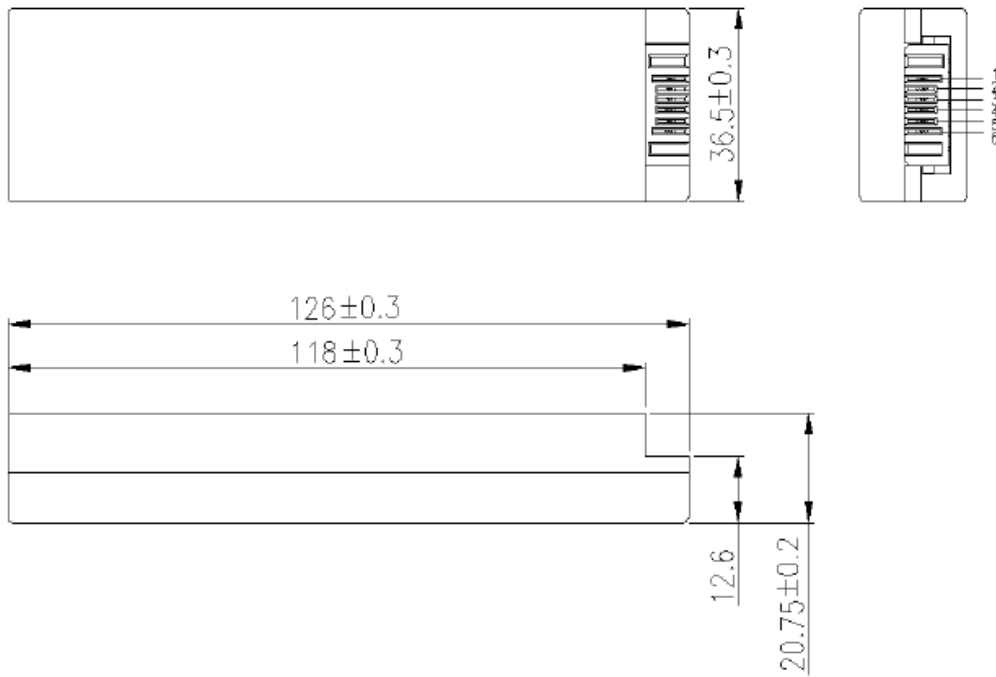

Battery (Unit: mm)

Circuit diagram:

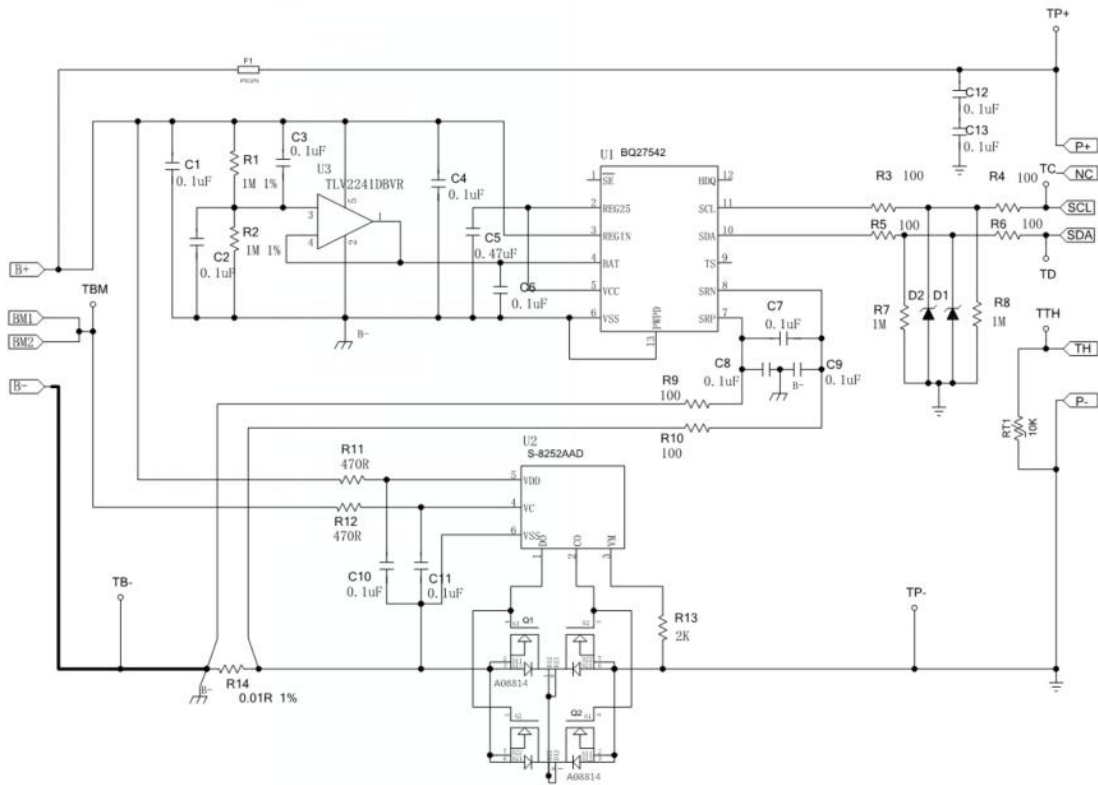

Summary of Testing:

The battery pack is evaluated and tested in this test report according to DENAN appendix 9.

Testing location:**Shenzhen LCS Compliance Testing Laboratory Ltd.**

Xingyuan Industrial Park, Tongda Road, Bao'an Avenue, Bao'an District, Shenzhen, Guangdong, China

Test item:

- 2.(1) Continuous Low Rate Charge;
- 2.(2) Vibration;
- 2.(3) Battery enclosure test at high ambient temperature
- 2.(4) Temperature cycling;
- 3.(1) External short circuit;
- 3.(2) Free fall;
- 3.(3) Mechanical shock (crash hazard)
- 3.(4) Thermal abuse;
- 3.(5) Crushing of cells;
- 3.(6) Low pressure;
- 3.(7) Overcharge;
- 3.(8) Forced discharge;
- 3.(9) Cell protection against a high charging rate;
- 3.(10) Forced internal short circuit of cells;
- 3.(11) Function of the overvoltage protection of batteries.

Clause	Requirement - Test	Result - Remark	Verdict
1.	Basic Design		P
1.(1)	Insulation and Wiring		P
	a) Insulation Resistance between an accessible metal case (excluding electrical contacts) and positive terminals $\geq 5M\Omega$.	No metal on the case.	N/A
	b) Internal wiring and insulation are sufficient to withstand maximum anticipated current, voltage and temperature requirements		P
	c) Orientation of wiring maintains adequate creepage and clearance distances between conductors. Mechanical integrity of internal connections are sufficient to accommodate conditions of reasonably foreseeable misuse.		P
1.(2)	Inner Pressure Reduction Mechanism		P
	a) Battery cases and cells incorporate a pressure relief mechanism or are constructed so that they relieve excessive internal pressure at a value and rate that will preclude rupture, explosion and self-ignition.	Venting mechanism exists on the top cell.	P
	b) Encapsulation used to support cells within an outer casing does not cause the battery to overheat during normal operation no inhibit pressure relief.		N/A
1.(3)	Temperature and current management		P
	The batteries are designed such that abnormal temperature rise conditions are prevented.	Overcharge, over-discharge, over current and short-circuit proof circuit used in this battery. See tests of clause 3.	P
	Means is provided to limit current to safe levels during charge and discharge.	Overcharge, over-discharge, over current and short-circuit proof circuit used in this battery. See tests of clause 3.	P
1.(4)	Terminal contacts		P
	a) Terminals have a clear polarity marking on the external surface of the battery or be designed with no fear of misconnection.	The terminals are special DC connector.	P
	b) The size and shape of the terminal contacts ensure that they can carry the maximum anticipated current.	The DC connector complied with the requirements.	P
	c) External terminal contact surfaces are formed from conductive materials with good mechanical strength and corrosion resistance.	The DC connector complied with the requirements.	P
	Terminal contacts are arranged to minimize the risk of short circuits.	The DC connector are separated by insulation plastic enclosure, and cannot be short-circuited in normal use.	P

Clause	Requirement - Test	Result - Remark	Verdict
1.(5)	Assembly of cells into batteries		P
	Cells used in the battery assembly have closely matched capacities, are of the same design, and are of the same chemistry and same manufacturer.	2S4P	P
	The battery incorporates separate circuitry to prevent cell reversal from uneven charges as the pack is designed for the selective discharge of a portion of its series connected cells.		N/A
2.	Intended Use		P
2.(1)	Continuous Low Rate Charge		P
	Fully charged cells are subjected for 28 days to a charge as specified by the manufacturer.	Arrange the test as required.	P
	Ambient temperature when testing	45°C	P
	Results: no fire, no explosion, no leakage	No fire, no explosion, no leakage.	P
2.(2)	Vibration		P
	The measured open circuit voltage of the fully charged cells or batteries is within anticipated parameters	See test below.	P
	The cells or batteries are subjected to a vibration sequence with amplitude of 0.76 mm and a total maximum excursion of 1.52 mm. The frequency was varied at the rate of 1 Hz/min between the limits of 10 Hz and 55 Hz. The entire range of frequencies (10 Hz to 55 Hz) and return (55 Hz to 10 Hz) was traversed in 90 min ± 5 min for each mounting position.		P
	The vibration was applied in each of three mutually perpendicular directions.	Arrange the test as required.	P
	Results: no fire, no explosion, no leakage	No fire, no explosion, no leakage.	P
2.(3)	Battery enclosure test at high ambient temperature		P
	Fully charged batteries were placed in an air-circulating oven at a temperature of 70°C ± 2°C for 7 hours. Afterwards, they are removed and allowed to return to room temperature.	Arrange the test as required.	P
	Results: no physical distortion of the battery casing resulting in exposure of internal components.	No physical distortion	P
2.(4)	Temperature cycling		P
	Fully charged cells or batteries were subjected to temperature cycling (+75°C, +20°C, -20°C, +20°C) in forced draught chambers according to the procedure.	Arrange the test as required.	P
	After the fifth cycle, the cells or batteries were stored at 20 ± 5°C for 7 days prior to examination.	Arrange the test as required.	P

Clause	Requirement - Test	Result - Remark	Verdict
	Results: No fire, no explosion, no leakage	No fire, no explosion, no leakage.	P
3	Reasonably foreseeable misuse		P
3.(1)	External short circuit	Tested applied	P
	a) Fully charged cells were subjected to a short circuit test at $55^{\circ}\text{C} \pm 5^{\circ}\text{C}$.	Arrange the test as required. Each 5pcs cells charged at ambient temperature 45°C and -5°C respectively prepared for the test.	P
	The external resistance did not exceed $80 \pm 20 \text{ m}\Omega$.	See table 3.(1)	P
	The cells were tested for 24 h or until the case temperature declined by 20% of the maximum temperature rise.	Tested until the case temperature declined by 20% of the maximum temperature rise.	P
	b) Fully charged batteries were subjected to a short circuit test at $20^{\circ}\text{C} \pm 5^{\circ}\text{C}$.	Arrange the test as required. Each 5pcs batteries charged at ambient temperature 45°C and -5°C respectively prepared for the test.	P
	The external resistance did not exceed $80 \pm 20 \text{ m}\Omega$.	See table 3.(1)	P
	The batteries were tested for 24 h or until the case temperature declined by 20% of the maximum temperature rise.	Tested for 24 hours.	P
	If battery incorporates protective device or protective circuit and the current has stopped, then for one hour after the current stopped.		P
	Results: no fire, no explosion.	No fire, no explosion.	P
3.(2)	Free fall	Arrange the test as required.	P
	Fully charged cells or batteries were dropped 3 times from a height of 1.0 m onto a concrete floor.		P
	Provided that this does not apply to charged batteries weighting more than 7 kg.		P
	Results: no fire, no explosion	No fire, no explosion.	P
3.(3)	Mechanical shock (crash hazard)		P
	a) Fully charged cells or batteries were subjected to a total of three shocks of equal magnitude applied in each of three mutually perpendicular directions.	Arrange the test as required.	P
	b) During the initial 3 milliseconds, the minimum average acceleration was 735 m/s^2 . The peak acceleration was between 1228 m/s^2 and 1716 m/s^2 .		P
	Results: no fire, no explosion, no leakage	No explosion, no leakage.	P
3.(4)	Thermal abuse		P

Clause	Requirement - Test	Result - Remark	Verdict
	Fully charged cells were placed in a gravity or circulating air-convection oven. The oven temperature was raised at a rate of 5°C/min ± 2°C/min to a temperature of 130°C ± 2°C. The cell remained at that temperature for 10 minutes before the test was discontinued.	Arrange the test as required. Each 5pcs cells charged at ambient temperature 45°C and -5°C respectively prepared for the test.	P
	Results: no fire, no explosion	No fire, no explosion.	P
3.(5)	Crushing of cells	Tested applied	P
	a) Fully charged cells were crushed between two flat surfaces with a hydraulic ram exerting a force of 13 kN ± 1 kN.	Arrange the test as required. Each 5pcs cells charged at ambient temperature 45°C and -5°C respectively prepared for the test.	P
	b) The force was released when		P
	(1) the maximum forces applied	The Maximum force is achieved when the force applied crushing the cell	P
	(2) an abrupt voltage drop of one-third of the original voltage has been obtained		N/A
	(3) There was 10% deformation of battery height		P
	c) A cylindrical or prismatic cell was crushed with its longitudinal axis parallel to the flat surfaces of the crushing apparatus.	Prismatic cell	P
	A second set of cylindrical cells was tested, rotated 90 degrees around their longitudinal axis compared to the first set.		N/A
	Ambient temperature when testing	Ambient temperature 45°C and -5°C respectively.	P
	Results: no fire, no explosion.	No fire, no explosion.	P
3.(6)	Low pressure	Arrange the test as required.	P
	Fully charged cells are placed in a vacuum chamber whose internal pressure was gradually reduced to a pressure equal to or less than 11.6 kPa and held at that value for 6 hours.		P
	Results: no fire, no explosion, no leakage	No fire, no explosion, no leakage.	P
3.(7)	Overcharge	Tested applied	P
	A discharged cell was charged from a power supply of ≥ 10 V, at a charging current I_{rec} recommended by the manufacturer for 2.5 C_5/I_{rec} hours or until it reach the test voltage.	Arrange the test as required. Each 5pcs cells overcharged at ambient temperature 45°C and -5°C respectively during the test.	P
	Ambient temperature when testing	Ambient temperature 45°C and -5°C respectively.	P
	Results: no fire, no explosion.	No fire, no explosion.	P

Clause	Requirement - Test	Result - Remark	Verdict
3.(8)	Forced discharge		P
	Discharged cells intended for use in multi-cell applications, were subjected to a reverse charge at 1.0 I _t (A) for 90 minutes.	Arrange the test as required. Each 5pcs cells Forced discharge at ambient temperature 45°C and -5°C respectively during the test.	P
	Ambient temperature when testing	Ambient temperature 45°C and -5°C respectively.	P
	Results: no fire, no explosion	No fire, no explosion.	P
3.(9)	Cell protection against a high charging rate		P
	Discharged cells were charged at three times the charging current recommended by the manufacturer until	Arrange the test as required. Each 5pcs cells high charged at ambient temperature 45°C and -5°C respectively during the test.	P
	the cells was fully charged, or		P
	A protective devices in the equipment or battery cut off the charge current before the cell became fully charged.	No protective device exists on the cell.	N/A
	Ambient temperature when testing	Ambient temperature 45°C and -5°C respectively.	P
	Results: no fire, no explosion	No fire, no explosion.	P
3.(10)	Forced internal short circuit of cells	Tested applied	P
	Pressed the winding core of charged cell (except when electrolyte is not liquid) by pressing jig under condition that nickel peace was inserted.	Arrange the test as required. Each 5pcs cells charged at ambient temperature 45°C and -5°C respectively prepared for the test.	P
	Inserted between the positive active material and negative active material		P
	Inserted between the uncoated current collector of positive electrode and the active material coated negative active electrode		P
	Test was stopped when voltage drop of over 50 mV was obtained, or		N/A
	Stopped when the pressure reached 800 N (for prismatic cells, 400N).	The force reached 400N.	P
	Ambient temperature when testing	Ambient temperature 45°C and -5°C respectively.	P
	Number of test sample	Each 5pcs cells pressed at ambient temperature 45°C and -5°C respectively prepared for the test.	P
	Results: no fire, no explosion	No fire, no explosion.	P

Clause	Requirement - Test	Result - Remark	Verdict
3.(11)	Function of the overvoltage protection of batteries	Tested applied	P
	The cell block in the battery shall not exceed the upper limited charging voltage at $20 \pm 5^{\circ}\text{C}$ ambient temperature.		P
	a) For batteries made of a one cell block, the voltage applied to the cell block during charging shall be measured.		N/A
	b) For batteries consisting of a series of two pieces or more of cell blocks, it shall be charged while measuring the voltage of each cell block and at the same time, one cell block shall forcibly be discharged and the voltages of the other cell blocks shall gradually be measured.	2S4P	P
	c) For batteries consisting of a series of connection of two pieces or more of cell blocks, a voltage exceeding the upper limited charging voltage specified in Annex Table 1-2 shall be applied to the cell block while measuring the voltage of each cell block. When the charging stops, the voltage shall be measured.		N/A
	The battery provides with protective circuits		P
	Appliance in which battery is installed or battery charger provides with protective circuits.		P
3.(12)	Free fall of appliance		N/A
	The charged battery shall be installed to be used, and shall be dropped once a concrete floor or iron plate in a direction considered to most likely affect the battery in a negative manner.		N/A
	An equivalent load shall be applied to the battery		N/A
	Kind of equipment		N/A
	Weight of appliance		N/A
	Applicable standard		N/A
	Height in drop testing		N/A
	Results: no short-circuiting		N/A
4	Labeling		P
	Labeling for cells shall be provided as below on surface where it can easily be seen but not easily faded.	The label of cells meets the requirements.	P
	Rated voltage	See page 2	P
	Rated capacity	See page 2	P

TABLE 1: List of Critical Components					P
Object/part No.	Manufacturer/ trademark	Type/Model	Technical Data	Standard	Mark(s) of conformity ¹⁾
Cell	Sanyo Energy (U S A) Corp	UF463450F	3.7V, 920mAh	--	Tested with appliance
PCB	Shenzhen City Jiawantongda Circuit Co., Ltd	JWTD-M	V-0, 130°C	UL 796	UL E492187
-PCB (alternative)	Interchangeable	Interchangeable	V-0, 130°C	UL 796	UL approved
Protection IC (U1)	Texas Instruments	bq27542-G	V _{CC} : -0.3~2.75V, V _{BAT} : -0.3~6V, T _A : -40°C ~ +85°C	--	Tested with appliance
Protection IC (U2)	Seiko Instruments Inc.	S-8252AAD	Overcharge Protection Voltage: 4.28±0.02V, Overdischarge Protection Voltage : 2.4±0.05V, T _{opr} : -40°C~+85°C	--	Tested with appliance
Protection IC (U3)	Texas Instruments	TLV2241	V _{DD} : 2.7-10V, V _{IO} : 0.45V, T _A : -40°C ~ +125°C	--	Tested with appliance
MOSFET (Q1, Q2)	ALPHA & OMEGA SEMICONDUCTOR, LTD.	AO8814	V _{DS} : 20V, V _{GS} : ±12V, I _D : 7.5A, T _{stg} : -55°C~+150°C	--	Tested with appliance
Lead wire	Dongguan City Minghe Electronic Co., Ltd	2646	22AWG, 300V, 105°C , VW-1	UL 758	UL E473509
- Lead wire (alternative)	Interchangeable	Interchangeable	22AWG, 300V, 105°C , VW-1	UL 758	UL approved
Plastic Enclosure	FORMOSA CHEMICALS & FIBRE CORP PLASTICS DIV	AC383(X)(f2)	V-0, 130°C, Thickness: 1.0mm	UL 94	UL E162823
PTC (F1)	LITTELFUSE INC	VLP270(W27)	V _{max} : 16V, I _h : 2700mA, I _t : 6500mA, I _{max} : 60A, T _{moa} : 85°C	UL 1434	UL E74889
NTC (RT1)	MURATA	NCP18XH103F03 RB	10KΩ±1%, 3380	--	--
Supplementary information:					

TABLE: 2.(1) Continuous Low Rate Charge Test (Cell)					P
Model	Recommended Charging Method, CC, CV, or CC/CV	Recommended Charging Voltage Vc, Vdc	Recommended Charging Current Irec, mA	OCV at Start of Test, Vdc	Results
#1	CC and CV	4.20	182	4.19	P
#2	CC and CV	4.20	182	4.18	P
#3	CC and CV	4.20	182	4.18	P
#4	CC and CV	4.20	182	4.18	P
#5	CC and CV	4.20	182	4.17	P
Supplementary information: no fire, explosion or leakage observed					

TABLE: 2.(2) – Vibration Test (Cell)			P
Model	OCV at Start of Test, Vdc	Results	
#1	4.18	P	
#2	4.17	P	
#3	4.17	P	
#4	4.17	P	
#5	4.18	P	
Supplementary information: no fire, explosion or leakage observed			

TABLE: 2.(2) – Vibration Test (Battery Pack)			P
Model	OCV at Start of Test, Vdc	Results	
#1	8.38	P	
#2	8.38	P	
#3	8.37	P	
#4	8.37	P	
#5	8.37	P	
Supplementary information: no fire, explosion or leakage observed			

TABLE: 3.(1) – External Short Circuit Test (Cell)					P
Model	Ambient (At 55°C ± 5°C)	OCV at start of test, Vdc	Resistance of Circuit, Ω	Maximum Case Temperature Rise ΔT , °C	Results
Samples charged at charging temperature upper limit (45°C)					
#1	55.2	4.21	0.086	104.7	P
#2	55.2	4.21	0.085	101.4	P
#3	55.2	4.21	0.085	102.5	P
#4	55.2	4.20	0.086	104.2	P
#5	55.2	4.20	0.086	101.5	P
Samples charged at charging temperature lower limit (-5°C)					
#6	55.4	4.13	0.084	102.6	P
#7	55.4	4.13	0.083	108.2	P
#8	55.4	4.14	0.083	103.4	P
#9	55.4	4.14	0.082	101.8	P
#10	55.4	4.13	0.085	103.5	P
Supplementary information: no fire or explosion					

TABLE: 3.(1) – External Short Circuit Test (Battery Pack)					P
Model	Ambient (At 20°C ± 5°C)	OCV at start of test, Vdc	Resistance of Circuit, Ω	Maximum Case Temperature Rise ΔT , °C	Results
Samples charged at charging temperature upper limit (45°C)					
#1	23.9	8.43	0.085	24.9	P
#2	23.9	8.42	0.084	24.8	P
#3	23.9	8.42	0.084	24.8	P
#4	23.9	8.41	0.086	24.7	P
#5	23.9	8.42	0.082	24.8	P
Samples charged at charging temperature lower limit (-5°C)					
#6	23.8	8.35	0.085	24.9	P
#7	23.8	8.36	0.081	24.9	P
#8	23.8	8.36	0.084	24.7	P
#9	23.8	8.34	0.087	24.7	P
#10	23.8	8.36	0.084	24.8	P
Supplementary information: no fire or explosion					

TABLE: 3.(7) – Overcharge Tests (Lithium Systems)						P
Model	Ambient (At -5°C ± 2°C or 45°C ± 2°C)	OCV at start of test, Vdc	Maximum Charging Current, A	Maximum Charging Voltage, Vdc	Total Time of Charging, h	Results
#1	-5	3.22	0.92	10	2.5	P
#2	-5	3.22	0.92	10	2.5	P
#3	-5	3.24	0.92	10	2.5	P
#4	-5	3.25	0.92	10	2.5	P
#5	-5	3.22	0.92	10	2.5	P
#6	45	3.22	0.92	10	2.5	P
#7	45	3.24	0.92	10	2.5	P
#8	45	3.23	0.92	10	2.5	P
#9	45	3.23	0.92	10	2.5	P
#10	45	3.24	0.92	10	2.5	P
Supplementary information: No fire or explosion.						

TABLE: 3.(8) – Forced Discharge Test (Cell)					P
Model	Ambient (At -5°C ± 2°C or 45°C ± 2°C)	OCV before application of reverse charge, Vdc	Measured Reverse Charge It, A	Total Time for Reversed Charge Application, Min	Results
#1	-5	3.22	0.92	90	P
#2	-5	3.22	0.92	90	P
#3	-5	3.23	0.92	90	P
#4	-5	3.23	0.92	90	P
#5	-5	3.21	0.92	90	P
#6	45	3.21	0.92	90	P
#7	45	3.22	0.92	90	P
#8	45	3.23	0.92	90	P
#9	45	3.24	0.92	90	P
#10	45	3.22	0.92	90	P
Supplementary information: no fire or explosion					

TABLE: 3.(9) – Cell Protection Against a High Charging Rate Test (Lithium Systems)					P
Model	Ambient (At $-5^{\circ}\text{C} \pm 2^{\circ}\text{C}$ or $45^{\circ}\text{C} \pm 2^{\circ}\text{C}$)	OCV at start of test, Vdc	Maximum Charging Current, A	Maximum Charging Voltage, Vdc	Results
#1	-5	3.22	2.76	4.2	P
#2	-5	3.24	2.76	4.2	P
#3	-5	3.22	2.76	4.2	P
#4	-5	3.21	2.76	4.2	P
#5	-5	3.21	2.76	4.2	P
#6	45	3.22	2.76	4.2	P
#7	45	3.23	2.76	4.2	P
#8	45	3.22	2.76	4.2	P
#9	45	3.23	2.76	4.2	P
#10	45	3.21	2.76	4.2	P
Supplementary information: no fire or explosion					

TABLE: 3.(10) – Forced internal short circuit of cells					P
Model	Ambient (At $-5^{\circ}\text{C} \pm 2^{\circ}\text{C}$ or $45^{\circ}\text{C} \pm 2^{\circ}\text{C}$)	OCV at start of test, Vdc	Maximum applied pressure, (N)	Voltage drop, (mV)	Results
#1	-5	4.14	400	1	P
#2	-5	4.14	400	1	P
#3	-5	4.13	400	0	P
#4	-5	4.13	400	0	P
#5	-5	4.14	400	2	P
#6	45	4.21	400	1	P
#7	45	4.21	400	2	P
#8	45	4.22	400	0	P
#9	45	4.20	400	0	P
#10	45	4.21	400	1	P
Supplementary information: no fire or explosion					

TABLE: 3.(11) –Function of the overcharge protection of batteries				P
Model	OCV at start of test, Vdc	OCV at ens of test, Vdc	Charging Voltage, Vdc	Results
#1 Cell Block	3.88	4.24	10.0	P
#2 Cell Block	3.89	4.24	10.0	P
Supplementary information: no fire or explosion				

-- End of Report --

Product: Lithium-ion Battery Pack

Type Designation: BL3600F4634462S4PH6G



Figure 1 Front view of battery

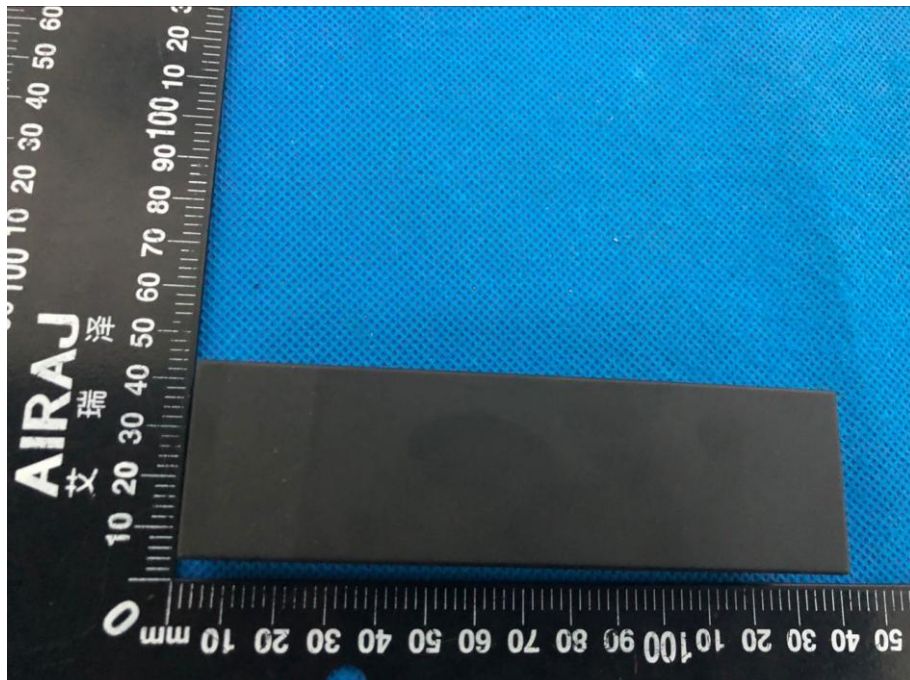

Figure 2 Back view of battery

Product: Lithium-ion Battery Pack

Type Designation: BL3600F4634462S4PH6G

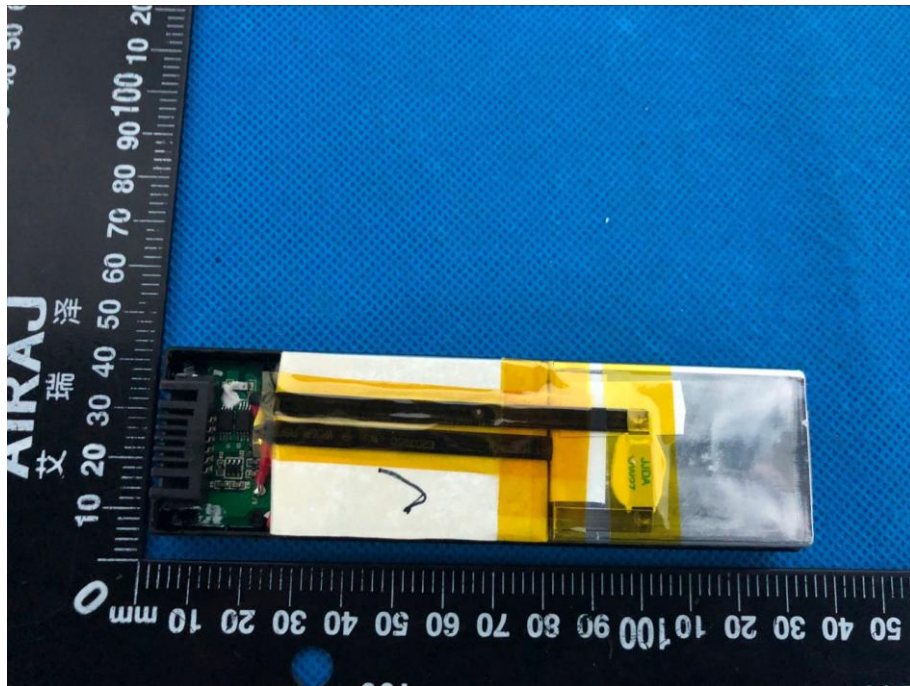

Figure 3 Internal view of battery

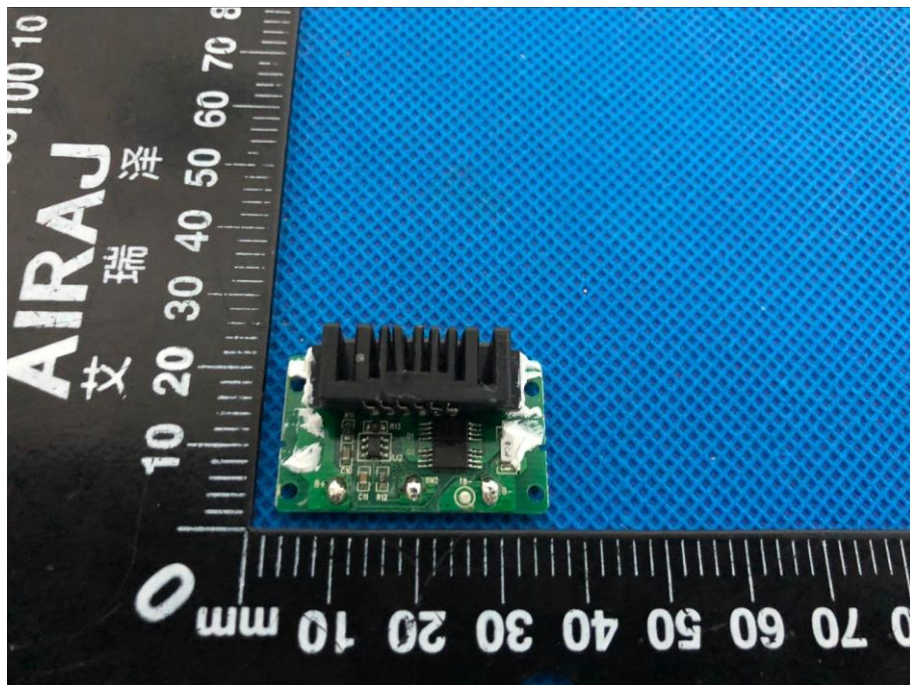

Figure 4 Front view of PCM

Product: Lithium-ion Battery Pack

Type Designation: BL3600F4634462S4PH6G

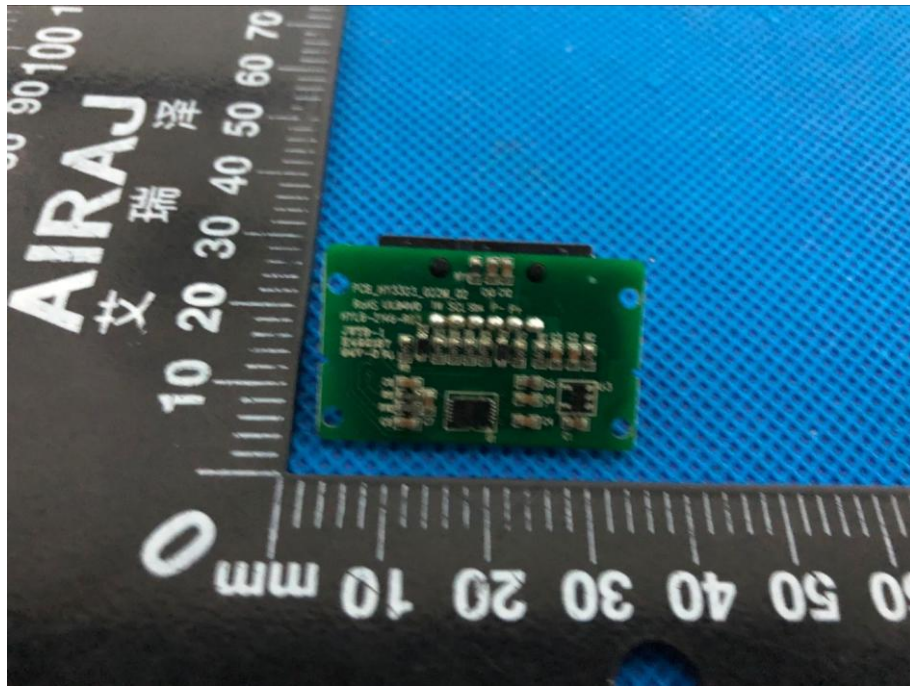

Figure 5 Back view of PCM

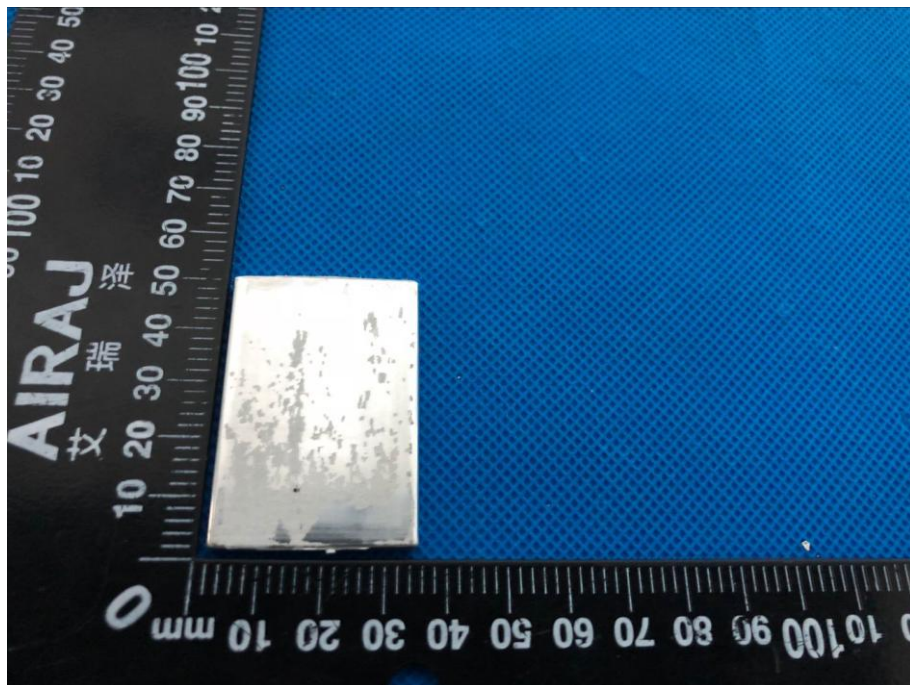

Figure 6 Front view of cell

Product: Lithium-ion Battery Pack

Type Designation: BL3600F4634462S4PH6G

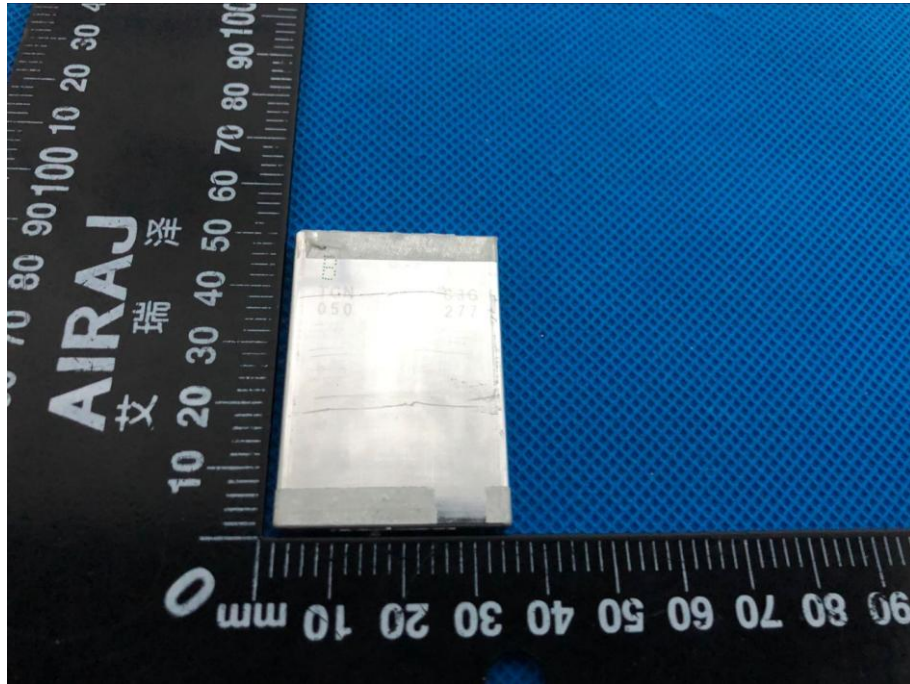

Figure 7 Back view of cell

Attachment 1

Equipment list

Page 1 of 2

Report No.: LCS180507172AS

Product: Lithium-ion Battery Pack

Type Designation: BL3600F4634462S4PH6G

Testing location: Shenzhen LCS Compliance Testing Laboratory Ltd.

Xingyuan Industrial Park, Tongda Road, Bao'an Avenue, Bao'an District, Shenzhen, Guangdong, China

Name	Manufacturer	Model No.
Data Collector	Agilent	34970A
Data Collector	Agilent	34970A
Stopwatch	Gongwen	PC396
Vibration Test Instrument	Dongling	ES-3-150
Vertical Shock Tester	Dongling	SY10-5
Battery Cursh Tester	Bell	BE-6045-2T
Battery Impact Tester	Bell	BE-5066
Battery Internal Short Circuit Tester	Bell	BE-6045W
Low Altitude Simulation Tester	Bell	BE-ZK-64
Battery Thermal Abuse Tester	Bell	BE-101-270B
Battery Short Circuit Tester	Bell	BE-1000A
Battery Burning Tester	Bell	BE-6046
Rapid Temperature Tester	Bell	BTKS-150C
Free Fall Tester	Bell	BF-F-315S
Battery Charge/Discharge Tester	Xinwei	CT-3008-5V10A-204
Battery Charge/Discharge Tester	Xinwei	CT-3008-5V10A-204
Glove Box	Etelux	Lab2000
Battery Charge/Discharge Tester	Xinwei	CT-3008-15V3A
Battery Charge/Discharge Tester	Xinwei	CT-3008-15V3A-A
Internal Resistance Tester	OPTEX	BTS-100
Digital multimeter	TES	TES2732
DC Power Supply	Chroma	62012P-80-60
Insulation Resistance Tester	Yangzi	CS2676CX-1
Battery Charge/Discharge Tester	Xinwei	CT-4008-6V4A-CCDC
Battery Charge/Discharge Tester	Xinwei	CT-4008-50V20A-ND
Electronic Balance	Yingheng	5003
Battery Charge/Discharge Tester	Xinwei	CT-3008-5V10A-204

Attachment 1

Equipment list

Product: Lithium-ion Battery Pack

Type Designation: BL3600F4634462S4PH6G

Name	Manufacturer	Model No.
Battery Charge/Discharge Tester	Xinwei	CT-3008-5V10A-204
Battery Charge/Discharge Tester	Xinwei	CT-3008-10V6A-A
Battery Charge/Discharge Tester	Xinwei	CT-3008-10V6A-A
Battery Acupuncture Tester	Xiangmin	XM-ZC001
Battery Charge/Discharge Tester	Repower	CTS 20V-5A
Battery Charge/Discharge Tester	Repower	CDS60V10A
Battery Charge/Discharge Tester	Repower	CDS-5V100A